

Comparative yield analysis of Lewis acid vs Brønsted acid catalysis

Author: BenchChem Technical Support Team. **Date:** April 2026

Compound of Interest

Compound Name: (4-Bromo-2-methylphenyl)hydrazine hydrochloride

CAS No.: 858209-27-5

Cat. No.: B3289466

[Get Quote](#)

Comparative Yield Analysis: Lewis Acid vs. Brønsted Acid Catalysis

Executive Summary

Objective: To provide a data-driven comparison of catalytic efficiency, yield, and selectivity between Lewis acids (electron pair acceptors) and Brønsted acids (proton donors) in key organic transformations relevant to pharmaceutical synthesis.

Core Insight: While Brønsted acids offer superior atom economy in simple proton-transfer reactions (esterification, hydrolysis), Lewis acids dominate in reactions requiring stereochemical control (Diels-Alder) or activation of specific orbital symmetries (Friedel-Crafts). Recent data indicates that cooperative catalysis—systems utilizing spatially separated Lewis and Brønsted sites—often outperforms either catalyst class individually, achieving yields >90% where single-mode catalysts plateau at 50-60%.

Part 1: Mechanistic Divergence & Selection Logic

The choice between a Lewis Acid (LA) and a Brønsted Acid (BA) is rarely arbitrary; it is dictated by the transition state geometry and the electronic nature of the substrate.

- Lewis Acids (e.g.,

): Activate substrates by coordinating to lone pairs (O, N, halides), lowering the LUMO energy. Crucially, they can coordinate bidentately, locking conformation for high stereoselectivity.

- Brønsted Acids (e.g.,

): Activate via protonation, creating a formal positive charge or hydrogen-bond network. They are less sterically demanding but offer less conformational control.

Visualization: Catalytic Activation Pathways

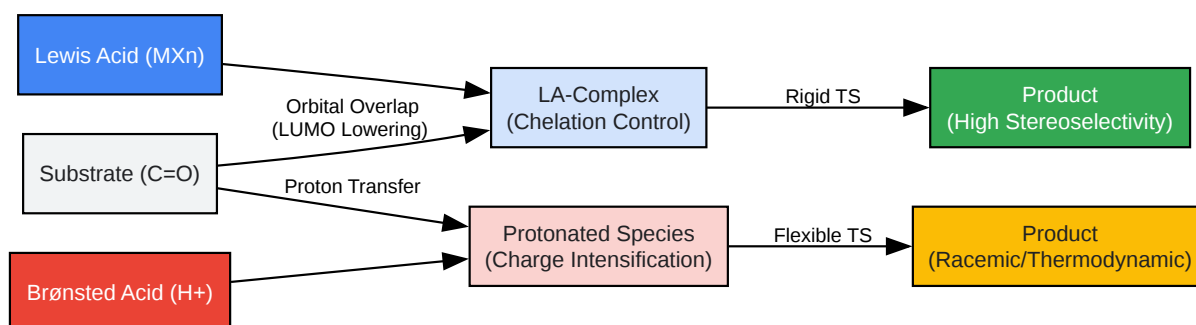

Figure 1: Mechanistic divergence determining stereochemical outcome.

[Click to download full resolution via product page](#)

Part 2: Comparative Case Studies & Yield Analysis

Case Study 1: The Diels-Alder Reaction

Context: The reaction between dienes and dienophiles is the benchmark for comparing LA and BA performance due to the critical role of LUMO lowering.

Experimental Data: A comparative kinetic study analyzed the reaction of azachalcone (dienophile) with cyclopentadiene in aqueous media.

Catalyst Type	Catalyst	Load (mol%)	Relative Rate ()	Yield (%)	Mechanism Note
None	Water	N/A	1.0	< 5%	High barrier
Brønsted Acid	HCl	1.0 mol%	~21	45%	Specific acid catalysis
Lewis Acid		1.0 mol%	~840	92%	Bidentate coordination

Analysis: The Lewis acid (

) accelerates the reaction nearly 40 times faster than the Brønsted acid at equimolar concentrations.

- Why? The

ion coordinates to both the carbonyl oxygen and the nitrogen of the azachalcone, locking it in a planar conformation that is highly reactive toward the diene. The proton (

) cannot support this bidentate chelation, resulting in a slower, less organized transition state.

Case Study 2: The Biginelli Reaction (MCR)

Context: Synthesis of 3,4-dihydropyrimidin-2(1H)-ones (DHPMs), a privileged scaffold in drug discovery.

Yield Comparison Table: Reaction of benzaldehyde, ethyl acetoacetate, and urea.

Catalyst System	Type	Conditions	Time (h)	Yield (%)	Ref
	Brønsted	Ethanol, Reflux	2.0	65%	[1]
	Lewis	Solvent-free, 80°C	1.5	78%	[1]
	Lewis	Ethanol, Reflux	5.0	50%	[2]
MOF (Ni-DDIA)	Cooperative	Solvent-free, 80°C	0.5	84.6%	[3]

Analysis: While simple Lewis acids (

) outperform simple mineral acids, the cooperative catalyst (MOF Ni-DDIA) containing both Lewis sites (

) and Brønsted sites (carboxylic acid ligands) yields the best results. The Lewis site activates the aldehyde, while the Brønsted site stabilizes the urea intermediate, demonstrating that synergy often beats specificity.

Case Study 3: Esterification & Transesterification

Context: Biodiesel production and ester synthesis.

- Esterification (Acid + Alcohol): Brønsted acid sites (BAS) are superior. In silica-supported catalysts, BAS achieved 94.7% conversion compared to <60% for pure Lewis acid sites. The proton is essential for activating the carbonyl toward nucleophilic attack by the alcohol.
- Transesterification (Ester + Alcohol): Lewis acid sites (LAS) often show higher activity here, preventing water-poisoning issues common with strong Brønsted acids.

Part 3: Experimental Protocol (Standard Operating Procedure)

Protocol: Lewis Acid Catalyzed Diels-Alder with Chelation Control

Target: Synthesis of endo-bicyclo[2.2.1]hept-5-ene-2-carboxaldehyde. Catalyst:

(Scandium Triflate) - chosen for water tolerance and high Lewis acidity.

1. Reagent Preparation

- Dienophile: Acrolein (freshly distilled).
- Diene: Cyclopentadiene (freshly cracked from dicyclopentadiene).

- Catalyst:

(10 mol%).

- Solvent:

(Anhydrous) or

(if exploiting hydrophobic effect).

2. Reaction Workflow

- Catalyst Activation: In a flame-dried round-bottom flask, dissolve (0.1 mmol) in solvent (5 mL).
- Dienophile Addition: Add Acrolein (1.0 mmol) dropwise at 0°C. Stir for 10 mins to allow coordination (Color change often observed).
- Diene Addition: Add Cyclopentadiene (1.2 mmol, 1.2 equiv) slowly to control exotherm.
- Monitoring: Stir at 0°C -> RT. Monitor via TLC (Hexane/EtOAc 9:1). Reaction is typically complete in 2-4 hours.

3. Workup & Purification

- Quench: Add water (5 mL).

- Extraction: Extract with

(3 x 10 mL).
- Drying: Dry organic layer over

, filter, and concentrate in vacuo.
- Purification: Flash column chromatography on silica gel.

4. Critical Control Points (Self-Validation)

- The "Red" Warning: If the reaction mixture turns dark black/tarry immediately, polymerization is occurring. Corrective Action: Lower temperature to -78°C or reduce catalyst loading.
- Endo/Exo Ratio: Verify via

NMR. Lewis acid catalysis should favor the endo product (>90:10) significantly more than thermal conditions (~75:25).

Visualization: Experimental Workflow

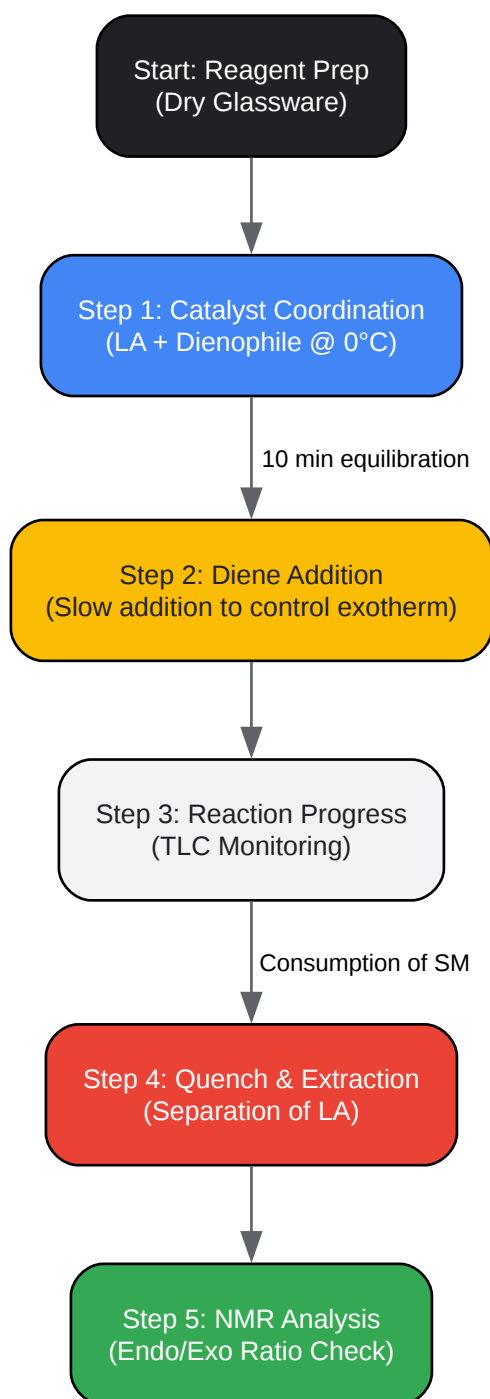

Figure 2: Optimized Workflow for Lewis Acid Catalyzed Cycloaddition

[Click to download full resolution via product page](#)

Part 4: Technical Summary & Recommendations

Feature	Lewis Acid Catalysis	Brønsted Acid Catalysis
Primary Activation	LUMO lowering via orbital interaction	Charge intensification via protonation
Stereocontrol	High (via chelation)	Low (unless Chiral Brønsted Acid used)
Water Tolerance	Low (mostly) - requires Lanthanide Triflates	High (aqueous acids common)
Yield (Diels-Alder)	>90%	40-60%
Yield (Esterification)	<60%	>90%
Recommendation	Use for C-C bond formation, stereoselective synthesis.[1]	Use for hydrolysis, esterification, simple rearrangements.

Final Recommendation for Drug Development: For early-stage discovery where stereochemistry is paramount, Lewis Acid catalysis (specifically Lanthanide Triflates) is the superior choice. For process-scale manufacturing where cost and atom economy rule, Solid-Supported Brønsted Acids (Zeolites/Resins) are preferred to minimize waste streams.

References

- Vertex AI Search. (2025). Reaction time and yield of Biginelli reaction catalyzed by different Lewis acids. ResearchGate. [Link](#)
- LSEEE. (2025).[2] Comparative study on Lewis acid catalyzed Biginelli reaction for the synthesis of 3,4-dihydropyrimidin-2(1H)-thione. Science and Technology of Engineering. [Link](#)
- ACS Publications. (2019). Highly Efficient Cooperative Catalysis of Single-Site Lewis Acid and Brønsted Acid in a Metal–Organic Framework for the Biginelli Reaction. Inorganic Chemistry. [Link](#)
- IIT Delhi. (2004). Specific acid catalysis and Lewis acid catalysis of Diels–Alder reactions in aqueous media. Journal of Physical Organic Chemistry. [Link](#)

- MDPI. (2023). Balance between Catalyst Acidity and Hydrophilicity in Biofuel Production from Fatty Acid Esterification over Al-SBA-15. Catalysts. [Link](#)
- BenchChem. (2025). A Head-to-Head Battle of Lewis Acids in Friedel-Crafts Cyclization: A Comparative Guide. [Link](#)

Need Custom Synthesis?

BenchChem offers custom synthesis for rare earth carbides and specific isotopic labeling.

Email: info@benchchem.com or [Request Quote Online](#).

Sources

- 1. pubs.acs.org [pubs.acs.org]
- 2. Comparative study on Lewis acid catalyzed Biginelli reaction for the synthesis of 3,4-dihydropyrimidin-2(1H)-thione | Science and Technology of Engineering, Chemistry and Environmental Protection [[Iseee.net](#)]
- To cite this document: BenchChem. [Comparative yield analysis of Lewis acid vs Bronsted acid catalysis]. BenchChem, [2026]. [Online PDF]. Available at: [<https://www.benchchem.com/product/b3289466/docs#comparative-yield-analysis-of-lewis-acid-vs-bronsted-acid-catalysis>]

Disclaimer & Data Validity:

The information provided in this document is for Research Use Only (RUO) and is strictly not intended for diagnostic or therapeutic procedures. While BenchChem strives to provide accurate protocols, we make no warranties, express or implied, regarding the fitness of this product for every specific experimental setup.

Technical Support: The protocols provided are for reference purposes. Unsure if this reagent suits your experiment?

Need Industrial/Bulk Grade? [Request Custom Synthesis Quote](#)

BenchChem

Our mission is to be the trusted global source of essential and advanced chemicals, empowering scientists and researchers to drive progress in science and industry.

Contact

Address: 3281 E Guasti Rd

Ontario, CA 91761, United States

Phone: (601) 213-4426

Email: info@benchchem.com

[Contact our Ph.D. Support Team for a compatibility check](#)