

5-Chloro-2-ethoxypyridin-4-ol safety data sheet (SDS)

Author: BenchChem Technical Support Team. **Date:** April 2026

Compound of Interest

Compound Name: 5-Chloro-2-ethoxypyridin-4-ol

CAS No.: 856965-85-0

Cat. No.: B3289288

[Get Quote](#)

Part 1: Executive Summary & Strategic Context

5-Chloro-2-ethoxypyridin-4-ol (CAS: 856965-85-0) is a specialized heterocyclic scaffold utilized primarily in the development of pharmaceuticals targeting enzymatic pathways, specifically as an analog precursor in the synthesis of dihydropyrimidine dehydrogenase (DPD) inhibitors (e.g., Gimeracil-class compounds) and COX-2 inhibitors.

Unlike standard commodity chemicals, this compound exhibits tautomeric complexity (4-hydroxypyridine \rightleftharpoons 4-pyridone) and possesses multiple reactive sites (C5-Cl, C4-OH, C2-Ethoxy). Its handling requires a nuanced understanding of halogenated pyridine chemistry to prevent inadvertent degradation or uncontrolled exothermic events during functionalization.

This guide moves beyond the static limitations of a standard Safety Data Sheet (SDS). It integrates GHS-compliant safety data with operational workflows, ensuring that researchers can not only handle the material safely but also maximize its stability and synthetic utility.

Part 2: Physicochemical Profile

The following data aggregates experimental and predicted values for CAS 856965-85-0.

| Property | Technical Specification |
|-------------------|--|
| Chemical Name | 5-Chloro-2-ethoxypyridin-4-ol |
| Synonyms | 5-Chloro-2-ethoxy-4-hydroxypyridine; 5-Chloro-2-ethoxy-4(1H)-pyridinone (Tautomer) |
| CAS Number | 856965-85-0 |
| Molecular Formula | C ₇ H ₈ ClNO ₂ |
| Molecular Weight | 173.60 g/mol |
| Physical State | Solid (Powder or Crystalline) |
| Color | White to Pale Yellow |
| Solubility | Soluble in DMSO, Methanol, DMF; Sparingly soluble in water (neutral pH) |
| pKa (Predicted) | ~6.5 - 7.5 (4-OH group) |
| Storage Condition | 2–8°C, Inert Atmosphere (Argon/Nitrogen), Protect from Light |

“

Critical Tautomer Note: In solution, this compound may exist in equilibrium with its pyridone form. This impacts NMR interpretation and nucleophilic substitution patterns. Always buffer NMR samples to a consistent pH to resolve tautomeric broadening.

Part 3: Hazard Identification & Risk Assessment

While specific toxicological data for this exact CAS is limited, structure-activity relationship (SAR) analysis with 5-chloro-2-hydroxypyridine analogs dictates the following Precautionary Safety Profile.

GHS Classification (Derived)

- Acute Toxicity, Oral: Category 4 (H302) – Harmful if swallowed.
- Skin Corrosion/Irritation: Category 2 (H315) – Causes skin irritation.
- Serious Eye Damage/Irritation: Category 2A (H319) – Causes serious eye irritation.
- STOT-SE (Respiratory): Category 3 (H335) – May cause respiratory irritation.

Operational Risk Matrix

- Dust Explosion Hazard: Finely divided organic powders pose a deflagration risk. Use anti-static weighing boats and ground all equipment.
- Reactive Incompatibility: Incompatible with strong oxidizing agents (e.g., KMnO_4) and strong bases (which deprotonate the 4-OH, potentially altering reactivity).

Part 4: Visualization – Safety Decision Logic

The following diagram illustrates the decision-making process for PPE selection and handling based on the quantity and state of the material.

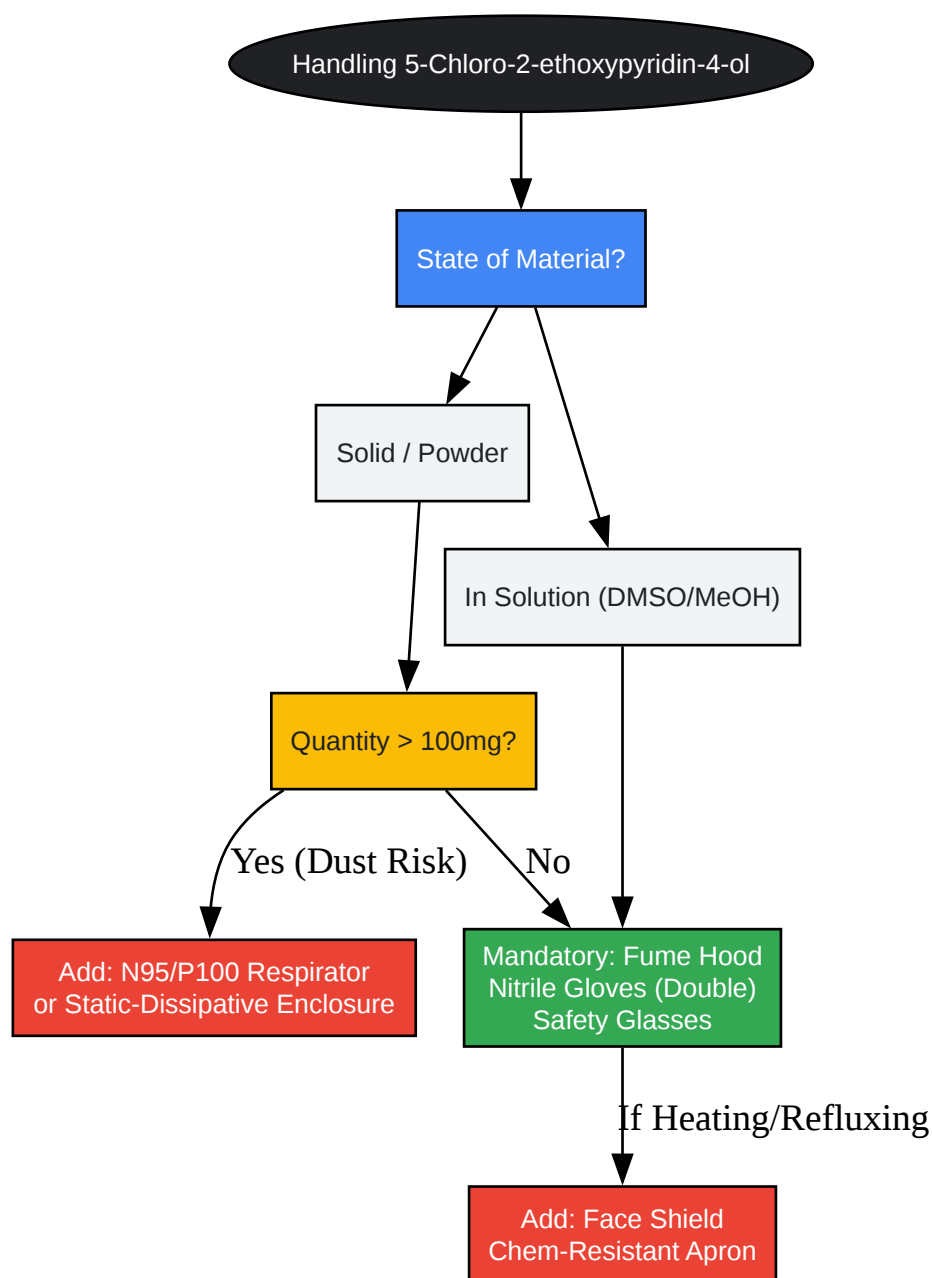

[Click to download full resolution via product page](#)

Caption: Decision matrix for PPE selection based on physical state and quantity, prioritizing respiratory protection for bulk solids.

Part 5: Operational Protocols (Self-Validating)

Protocol A: Safe Reaction Setup (O-Alkylation Example)

Context: A common workflow involves alkylating the 4-OH group. This reaction generates hydrogen gas and heat, requiring strict control.

1. Preparation & Validation

- Purity Check: Dissolve 1 mg in DMSO-d₆. Check ¹H NMR for impurity peaks at δ 8.0–9.0 ppm (indicative of oxidation/degradation).
- System Setup: Flame-dry a 2-neck round bottom flask. Purge with Argon for 15 minutes. Causality: Moisture competes with the base (e.g., NaH), reducing yield and creating fire hazards.

2. Reagent Addition (The "Portion-Wise" Rule)

- Dissolve **5-Chloro-2-ethoxypyridin-4-ol** (1.0 eq) in anhydrous DMF.
- Cool to 0°C.
- Add Base (e.g., NaH, 1.2 eq) portion-wise over 10 minutes.
- Checkpoint: Observe bubbling (H₂ evolution). Do not proceed until bubbling ceases. This confirms deprotonation is complete and prevents pressure buildup.

3. Quenching & Disposal (The Critical Safety Step)

- Never pour water directly into the reaction mixture if excess base remains.
- Dilute with Ethyl Acetate first.
- Add Saturated Ammonium Chloride (aq) dropwise at 0°C.
- Validation: Check pH of the aqueous layer. It should be neutral to slightly acidic (pH 6-7).

Protocol B: Emergency Response (Spill)

- Isolate: Evacuate the immediate area (10 ft radius).
- Protect: Don N95 mask and double nitrile gloves.

- Contain: Cover spill with a dry absorbent pad or vermiculite. Do not use water (spreads contamination).
- Clean: Sweep carefully into a sealable waste container. Wipe surface with 10% bleach, then water.

Part 6: Synthetic Utility & Pathway Visualization

Understanding the reactivity of the 5-Cl and 4-OH positions is crucial for safe experimental design. The 5-Cl position is deactivated but can participate in Suzuki couplings under specialized ligand conditions.

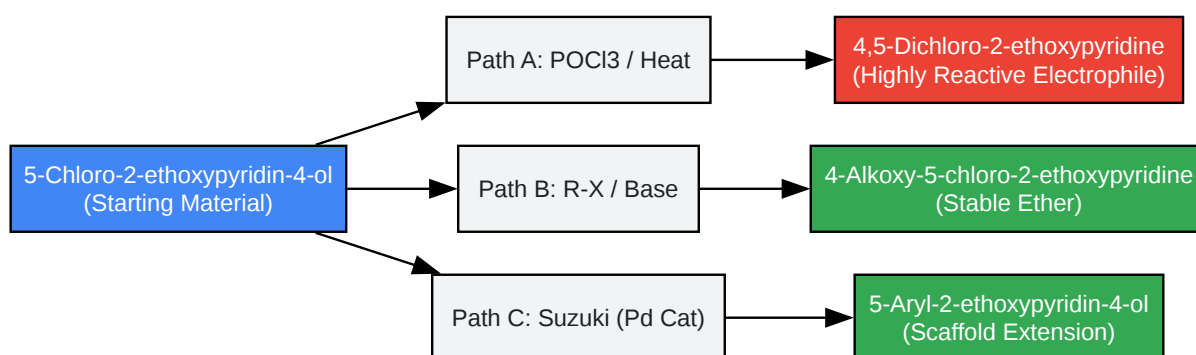

[Click to download full resolution via product page](#)

Caption: Synthetic divergence pathways. Path A generates a corrosive intermediate requiring strict moisture exclusion.

Part 7: References

- BLD Pharm. (2025). Safety Data Sheet: **5-Chloro-2-ethoxypyridin-4-ol** (CAS 856965-85-0). [1] Retrieved from
- Arctom Scientific. (2024). Product Analysis: **5-Chloro-2-ethoxypyridin-4-ol**. Retrieved from
- Kolder, C. R., & Hertog, H. J. (2010). [2][3] Synthesis and reactivity of 5-chloro-2,4-dihydroxypyridine. *Recueil des Travaux Chimiques des Pays-Bas*. Retrieved from

- PubChem. (2025).[4] Compound Summary: 5-Chloro-2-hydroxypyridine (Analog Safety Data). National Library of Medicine. Retrieved from

Need Custom Synthesis?

BenchChem offers custom synthesis for rare earth carbides and specific isotopic labeling.

Email: info@benchchem.com or [Request Quote Online](#).

Sources

- 1. [856965-85-0|5-Chloro-2-ethoxypyridin-4-ol|BLD Pharm \[bldpharm.com\]](#)
- 2. [semanticscholar.org \[semanticscholar.org\]](#)
- 3. [semanticscholar.org \[semanticscholar.org\]](#)
- 4. [5-Chloro-2-pyridone | C5H4ClNO | CID 77889 - PubChem \[pubchem.ncbi.nlm.nih.gov\]](#)
- To cite this document: BenchChem. [5-Chloro-2-ethoxypyridin-4-ol safety data sheet (SDS)]. BenchChem, [2026]. [Online PDF]. Available at: [\[https://www.benchchem.com/product/b3289288/docs#5-chloro-2-ethoxypyridin-4-ol-safety-data-sheet-sds\]](https://www.benchchem.com/product/b3289288/docs#5-chloro-2-ethoxypyridin-4-ol-safety-data-sheet-sds)

Disclaimer & Data Validity:

The information provided in this document is for Research Use Only (RUO) and is strictly not intended for diagnostic or therapeutic procedures. While BenchChem strives to provide accurate protocols, we make no warranties, express or implied, regarding the fitness of this product for every specific experimental setup.

Technical Support: The protocols provided are for reference purposes. Unsure if this reagent suits your experiment?

Need Industrial/Bulk Grade? [Request Custom Synthesis Quote](#)

BenchChem

Our mission is to be the trusted global source of essential and advanced chemicals, empowering scientists and researchers to drive progress in science and industry.

Contact

Address: 3281 E Guasti Rd

Ontario, CA 91761, United States

Phone: (601) 213-4426

Email: info@benchchem.com

[Contact our Ph.D. Support Team for a compatibility check](#)