

Application Note: Regioselective Functionalization of 4-Bromo-1-fluoro-2-naphthaldehyde

Author: BenchChem Technical Support Team. **Date:** April 2026

Compound of Interest

Compound Name:	4-Bromo-1-fluoro-2-naphthaldehyde
CAS No.:	842136-64-5
Cat. No.:	B3287252

[Get Quote](#)

Executive Summary & Chemical Logic

The utility of **4-Bromo-1-fluoro-2-naphthaldehyde** lies in its electronic asymmetry. The naphthalene core is polarized by the electron-withdrawing aldehyde at C2, which activates the C1-Fluorine bond toward Nucleophilic Aromatic Substitution (S_NAr). Simultaneously, the C4-Bromine bond remains chemically distinct, serving as a robust handle for Palladium-catalyzed cross-coupling.

Successful derivatization requires a strict Order of Operations to prevent chemoselectivity errors. This guide defines the protocols for orthogonal functionalization, prioritizing the preservation of the aldehyde functionality until the final stage.

Reactivity Map

The following diagram illustrates the three distinct reactive zones and their governing mechanisms.

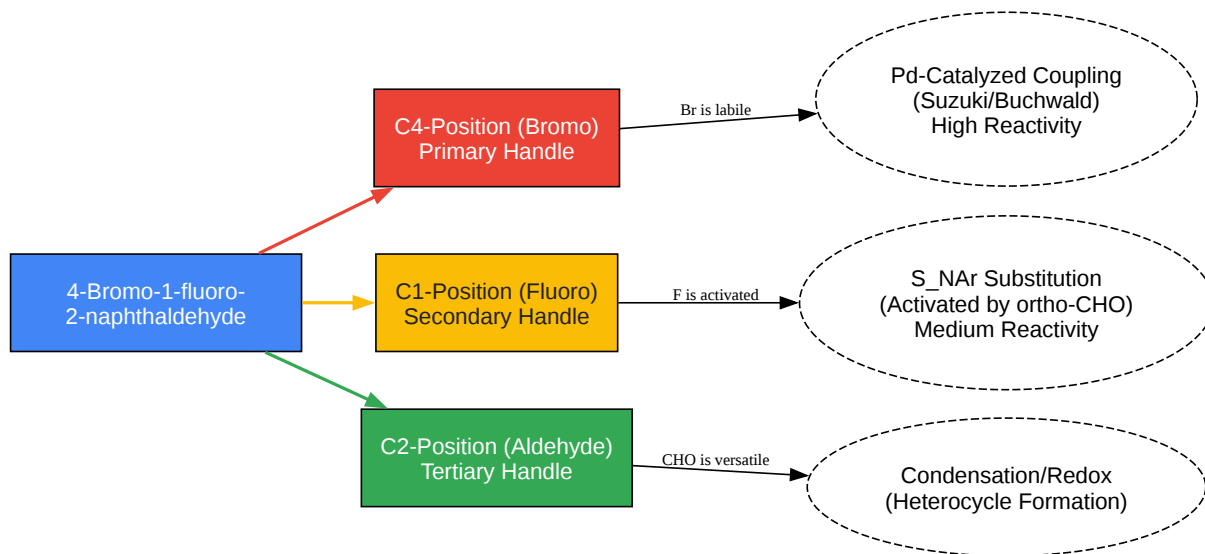

[Click to download full resolution via product page](#)

Figure 1: Orthogonal reactivity zones of the naphthalene scaffold. C4 allows carbon-carbon bond formation; C1 allows heteroatom introduction; C2 serves as a scaffold anchor.

Critical Analysis of Regioselectivity

To achieve high yields, one must exploit the electronic differences between the C1 and C4 positions.

Feature	C4-Bromine	C1-Fluorine	Mechanistic Implication
Bond Energy	Weak (C-Br)	Strong (C-F)	Br is preferred for oxidative addition (Pd ⁰ /Pd ²⁺).
Electronic Env.	Electron Neutral	Electron Deficient	C1 is activated for nucleophilic attack by the ortho-CHO group.
Reaction Type	Cross-Coupling	SNAr	Orthogonal conditions allow sequential editing.
Preferred Order	Step 1	Step 2	Perform Pd-coupling first. SNAr conditions (bases/heat) may degrade the C-Br bond if done first.

Experimental Protocols

Workflow A: C4-Selective Suzuki-Miyaura Coupling

Objective: Install an aryl or alkyl group at C4 without disturbing the C1-F or C2-CHO moieties.

Rationale: The C-Br bond undergoes oxidative addition with Pd(0) significantly faster than the C-F bond. Weak bases are used to prevent premature SNAr at C1.

Materials

- Substrate: **4-Bromo-1-fluoro-2-naphthaldehyde** (1.0 equiv)
- Boronic Acid: Arylboronic acid (1.2 equiv)
- Catalyst: Pd(dppf)Cl₂[1]·CH₂Cl₂ (3-5 mol%) - Chosen for stability and resistance to defluorination.
- Base: Na₂CO₃ (2.0 equiv, 2M aqueous)

- Solvent: 1,4-Dioxane (degassed)

Step-by-Step Protocol

- Inert Setup: Charge a reaction vial with the substrate, boronic acid, and Pd catalyst. Seal and purge with Argon for 5 minutes.
- Solvent Addition: Add degassed 1,4-Dioxane (0.2 M concentration relative to substrate).
- Activation: Add the aqueous Na₂CO₃ solution via syringe.
- Reaction: Heat the mixture to 80°C for 4–6 hours.
 - Note: Monitor by TLC/LCMS. Do not exceed 100°C to avoid affecting the C1-F bond.
- Workup: Cool to RT. Dilute with EtOAc and wash with water (x2) and brine. Dry over Na₂SO₄ and concentrate.
- Purification: Flash chromatography (Hexanes/EtOAc gradient). The product will typically be less polar than the starting material.

Workflow B: C1-Selective S_NAr Substitution

Objective: Displace the C1-Fluorine with an amine or thiol nucleophile. Rationale: The aldehyde at C2 is strongly electron-withdrawing (-M effect), activating the ortho-fluorine. The C4-Bromine (or the group installed in Workflow A) generally remains stable under these mild basic conditions.

Materials

- Substrate: **4-Bromo-1-fluoro-2-naphthaldehyde** (or C4-functionalized derivative)
- Nucleophile: Primary/Secondary Amine or Thiol (1.1–1.5 equiv)
- Base: K₂CO₃ (2.0 equiv) or DIPEA (for amines)
- Solvent: DMF or DMSO (Dry)

Step-by-Step Protocol

- Dissolution: Dissolve the substrate in dry DMF (0.5 M).
- Reagent Addition: Add the base followed by the nucleophile.
 - Critical: If using a volatile amine, add it slowly at 0°C to prevent exotherm-induced decomposition.
- Reaction: Stir at RT to 60°C.
 - Optimization: Highly nucleophilic amines (e.g., morpholine) react at RT. Thiols may require mild heating (50°C).
 - Warning: Avoid temperatures >100°C to prevent nucleophilic attack on the aldehyde (Cannizzaro or condensation side reactions).
- Workup: Pour the reaction mixture into ice water. The product often precipitates. Filter or extract with EtOAc/Et₂O.
- Purification: Recrystallization is often sufficient due to the high conversion.

Workflow C: C2-Directed Heterocyclization (Quinoline Synthesis)

Objective: Convert the C2-aldehyde and the newly installed C1-amine into a fused heterocyclic ring. Context: This is typically the final step, converting the naphthalene into a benzo[h]quinoline or similar fused system.

Friedländer-Type Condensation Protocol

- Substrate: C1-Amino-2-naphthaldehyde derivative.
- Partner: Ketone or Acetyl-bearing reagent (e.g., acetone, acetophenone).
- Catalyst: Piperidine (10 mol%) or NaOH (aq).
- Conditions: Reflux in Ethanol for 2–8 hours.
- Result: Formation of a tricyclic aromatic system.

Sequential Logic & Troubleshooting

The following decision tree illustrates the recommended synthetic pathway to maximize yield and purity.

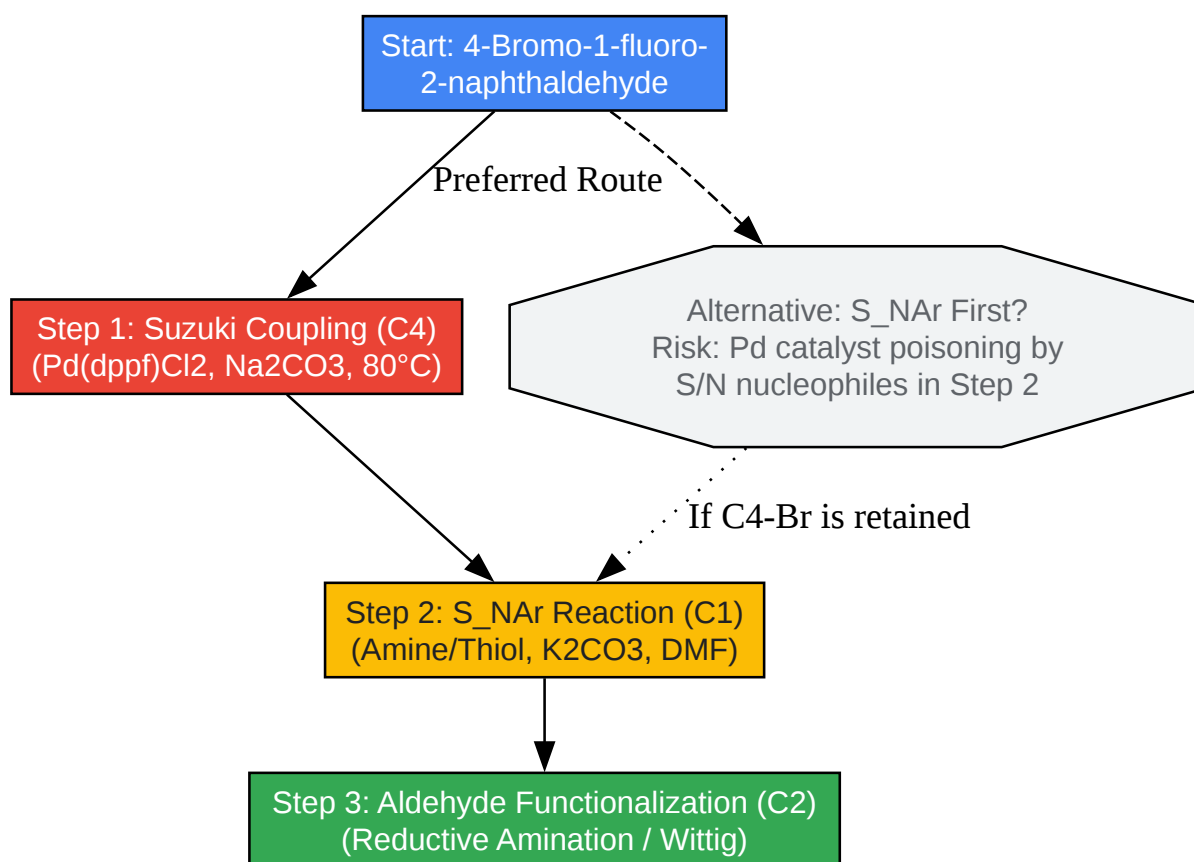

[Click to download full resolution via product page](#)

Figure 2: Strategic workflow. The "C4 First" approach is recommended to avoid catalyst poisoning by heteroatoms introduced at C1.

Troubleshooting Table

Issue	Probable Cause	Solution
Low Yield in Suzuki (C4)	Protodebromination	Use anhydrous solvents; switch to Pd(PPh ₃) ₄ .
No Reaction in SNAr (C1)	Nucleophile too weak	Switch solvent to DMSO; increase temp to 80°C; use Cs ₂ CO ₃ .
Aldehyde Degradation	Cannizzaro reaction	Ensure reaction environment is not strongly basic (pH > 12) for extended periods.
C1-F Loss during Suzuki	Oxidative addition at C-F	Use electron-rich ligands (e.g., PCy ₃) or stick to Pd(II) precatalysts; lower temp.

Safety & Handling

- HF Generation: While SNAr releases fluoride salts (e.g., KF), acidic workups can generate trace Hydrofluoric Acid (HF). Always work up SNAr reactions with basic or neutral buffers (NaHCO₃).
- Sensitizer: Naphthaldehydes are potential skin sensitizers. Use double gloving (Nitrile).
- Lachrymator: Halogenated aldehydes can be lachrymatory. Handle exclusively in a fume hood.

References

- Chemical Identity & Properties
 - PubChem. 4-Bromo-1-naphthaldehyde Compound Summary. National Library of Medicine. [Link](#)
- SNAr Mechanism on Naphthaldehydes
 - Singh, H. et al. A DFT investigation on aromatic nucleophilic substitution (SNAr) reaction between 4-fluoro-1-naphthaldehyde... and methylthiolate. ResearchGate, 2020. [Link](#)

- Suzuki Coupling Protocols
 - Yoneda Labs. Suzuki-Miyaura cross-coupling: Practical Guide. [Link](#)
 - Organic Chemistry Portal. Suzuki Coupling.[1][2][3][4] [Link](#)
- Regioselective Halogenation/Functionalization
 - ChemScene.[5] Product Data: **4-Bromo-1-fluoro-2-naphthaldehyde** (CAS 842136-64-5).
[5] [Link](#)

Need Custom Synthesis?

BenchChem offers custom synthesis for rare earth carbides and specific isotopic labeling.

Email: info@benchchem.com or [Request Quote Online](#).

Sources

- 1. Suzuki–Miyaura cross-coupling of unprotected ortho-bromoanilines with benzyl, alkyl, aryl, alkenyl and heteroaromatic boronic esters - PMC [[pmc.ncbi.nlm.nih.gov](https://pubmed.ncbi.nlm.nih.gov/)]
- 2. myers.faculty.chemistry.harvard.edu [myers.faculty.chemistry.harvard.edu]
- 3. ikm.org.my [ikm.org.my]
- 4. Suzuki Coupling [[organic-chemistry.org](https://www.organic-chemistry.org)]
- 5. chemscene.com [chemscene.com]
- To cite this document: BenchChem. [Application Note: Regioselective Functionalization of 4-Bromo-1-fluoro-2-naphthaldehyde]. BenchChem, [2026]. [Online PDF]. Available at: [<https://www.benchchem.com/product/b3287252/docs#application-note-regioselective-functionalization-of-4-bromo-1-fluoro-2-naphthaldehyde>]

Disclaimer & Data Validity:

The information provided in this document is for Research Use Only (RUO) and is strictly not intended for diagnostic or therapeutic procedures. While BenchChem strives to provide accurate protocols, we make no warranties, express or implied, regarding the fitness of this product for every specific experimental setup.

Technical Support: The protocols provided are for reference purposes. Unsure if this reagent suits your experiment?

Need Industrial/Bulk Grade? [Request Custom Synthesis Quote](#)

BenchChem

Our mission is to be the trusted global source of essential and advanced chemicals, empowering scientists and researchers to drive progress in science and industry.

Contact

Address: 3281 E Guasti Rd
Ontario, CA 91761, United States
Phone: (601) 213-4426
Email: info@benchchem.com

[Contact our Ph.D. Support Team for a compatibility check](#)