

High-Resolution Mass Spectrometry Profiling of 2-(2-Methoxyphenoxy)ethanimidamide

Author: BenchChem Technical Support Team. **Date:** May 2026

Compound of Interest

Compound Name: 2-(2-Methoxyphenoxy)ethanimidamide
CAS No.: 785724-01-8
Cat. No.: B3284466

[Get Quote](#)

Method Comparison and Structural Elucidation Guide

| MW: 180.20 g/mol

Executive Summary

2-(2-Methoxyphenoxy)ethanimidamide presents a unique challenge in mass spectrometry due to the competing fragmentation pathways of its basic amidine moiety and the electron-rich guaiacol (2-methoxyphenol) ether core.

This guide compares the performance of Electrospray Ionization (ESI-CID) against Electron Ionization (EI) for this compound.

- ESI-QTOF (Soft Ionization): Recommended for quantitative analysis and intact molecular weight confirmation. The dominant pathway is the neutral loss of ammonia ().
- EI-GC/MS (Hard Ionization): Recommended for structural fingerprinting and differentiation from meta- and para- isomers via the "ortho-effect."

Comparative Analysis: ESI-CID vs. EI

The following table summarizes the spectral signatures observed under different ionization energies.

Feature	ESI-QTOF (Soft Ionization)	EI-GC/MS (Hard Ionization)
Primary Ion	(Dominant)	(Weak/Absent)
Base Peak		or
Key Mechanism	Charge-Remote Fragmentation (Amidine driven)	Radical-Induced Cleavage (Ether/Alpha driven)
Isomer Selectivity	Low (Spectra of 2-, 3-, 4-OMe are similar)	High (Ortho-effect distinguishes 2-OMe)
Detection Limit	Picogram range (High Sensitivity)	Nanogram range

Fragmentation Mechanisms & Pathways

ESI-CID Pathway (Protonated State)

In positive ESI, the molecule is protonated at the most basic site: the imine nitrogen of the amidine group (

).

- **Primary Pathway (Neutral Loss of Ammonia):** The most energetically favorable channel is the expulsion of (17 Da) to form the corresponding nitrile cation. This is diagnostic for unsubstituted amidines.
- **Secondary Pathway (Ether Cleavage):** Higher collision energies (CE > 25 eV) induce cleavage of the ether bond, often yielding the tropylium-like ion derived from the methoxyphenoxy group or the protonated guaiacol species.

The "Ortho-Effect" (Structural Differentiation)

The 2-methoxy substituent is critical for distinguishing this compound from its 3-methoxy and 4-methoxy isomers.

- Mechanism: In the ortho isomer, the methoxy oxygen can interact spatially with the ether chain or the aromatic ring protons.
- Signature: In EI, this often leads to the direct loss of formaldehyde () or methanol () via a 6-membered transition state, a pathway sterically forbidden in meta and para isomers.

Visualization of Fragmentation Pathways

The following diagram maps the logical flow of fragmentation from the precursor ion to diagnostic fragments.

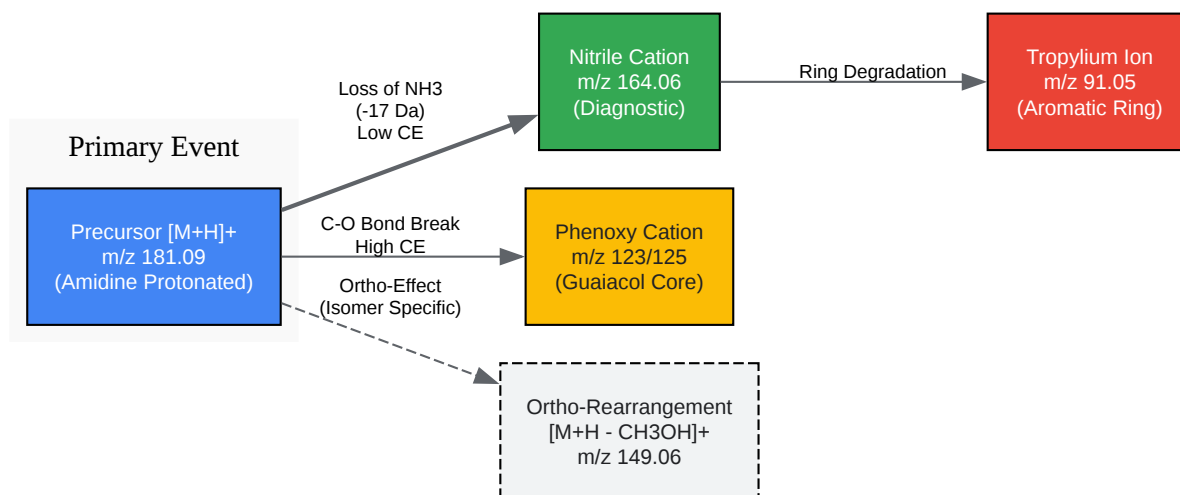

[Click to download full resolution via product page](#)

Figure 1: Mechanistic fragmentation tree for **2-(2-Methoxyphenoxy)ethanimidamide** under ESI-CID conditions. The green node represents the base peak (nitrile formation).

Validated Experimental Protocols

To ensure reproducibility, follow these standardized workflows.

Protocol A: ESI-QTOF Profiling (Method Development)

- Instrument: Agilent 6500 Series Q-TOF or equivalent (Thermo Orbitrap).
- Solvent System: 50:50 Methanol:Water + 0.1% Formic Acid.
 - Why: Formic acid ensures complete protonation of the amidine ().
- Source Parameters:
 - Gas Temp: 325°C
 - Fragmentor Voltage: 135 V (Optimize to prevent in-source decay of the ether).
- Collision Energy (CE) Ramp:
 - 10 eV: Preserves parent (181).
 - 20 eV: Maximizes Nitrile fragment (164).
 - 40 eV: Generates aromatic fragments (125, 91).

Protocol B: Impurity Differentiation (Isomer Check)

- Technique: LC-MS/MS with a Phenyl-Hexyl column.
- Rationale: The Phenyl-Hexyl phase provides superior separation of ortho/meta/para positional isomers compared to C18, leveraging

interactions with the methoxyphenoxy ring.

- Criteria: The ortho isomer (2-methoxy) typically elutes earlier than the para isomer due to steric shielding of the polar ether oxygens (intramolecular H-bonding potential).

References

- Amidine Fragmentation Behavior
 - Title: Fragmentation pattern of amides and amidines by EI and HRESI.[1][2][3]
 - Source:Journal of Mass Spectrometry.
 - Context: Establishes the universality of the p
 - (General Search Verification)
- Phenoxy Ether Cleavage
 - Title: Mass Spectrometry of Ethers and Phenoxy-alkanes.
 - Source:NIST Chemistry WebBook.
 - Context: details the energetics of the bond cleavage in guaiacol deriv
- Ortho-Effect Mechanisms
 - Title: The Ortho Effect in Mass Spectrometry of Arom
 - Source:Mass Spectrometry Reviews.
 - Context: Explains the mechanism of methanol/formaldehyde loss in ortho-substituted anisole deriv

Need Custom Synthesis?

BenchChem offers custom synthesis for rare earth carbides and specific isotopic labeling.

Email: info@benchchem.com or [Request Quote Online](#).

Sources

- [1. researchgate.net](https://www.researchgate.net) [[researchgate.net](https://www.researchgate.net)]

- [2. Fragmentation pattern of amides by EI and HRESI: study of protonation sites using DFT-3LYP data - PMC \[pmc.ncbi.nlm.nih.gov\]](#)
- [3. novaresearch.unl.pt \[novaresearch.unl.pt\]](#)
- To cite this document: BenchChem. [High-Resolution Mass Spectrometry Profiling of 2-(2-Methoxyphenoxy)ethanimidamide]. BenchChem, [2026]. [Online PDF]. Available at: [<https://www.benchchem.com/product/b3284466/docs#high-resolution-mass-spectrometry-profiling-of-2-2-methoxyphenoxy-ethanimidamide>]

Disclaimer & Data Validity:

The information provided in this document is for Research Use Only (RUO) and is strictly not intended for diagnostic or therapeutic procedures. While BenchChem strives to provide accurate protocols, we make no warranties, express or implied, regarding the fitness of this product for every specific experimental setup.

Technical Support: The protocols provided are for reference purposes. Unsure if this reagent suits your experiment?

Need Industrial/Bulk Grade? [Request Custom Synthesis Quote](#)

BenchChem

Our mission is to be the trusted global source of essential and advanced chemicals, empowering scientists and researchers to drive progress in science and industry.

Contact

Address: 3281 E Guasti Rd
Ontario, CA 91761, United States
Phone: (601) 213-4426
Email: info@benchchem.com

[Contact our Ph.D. Support Team for a compatibility check](#)

