

Theoretical and Computational Profiling of 4-(Chloro(phenyl)methyl)pyridine

Author: BenchChem Technical Support Team. **Date:** April 2026

Compound of Interest

Compound Name: 4-(Chloro(phenyl)methyl)pyridine

CAS No.: 740062-52-6

Cat. No.: B3281715

[Get Quote](#)

A Technical Guide on Synthesis, Electronic Structure, and Reactivity

Executive Summary

This technical guide provides a rigorous framework for the theoretical and computational study of **4-(Chloro(phenyl)methyl)pyridine** (4-CPMP). As a pivotal intermediate in the synthesis of second-generation antihistamines and potential antineoplastic agents, 4-CPMP represents a "privileged scaffold" containing both an electron-deficient pyridine ring and a reactive benzylic chloride.

This document moves beyond standard literature reviews to offer a predictive technical manual. It details the optimal Density Functional Theory (DFT) protocols for geometry optimization, validates synthetic pathways through thermodynamic modeling, and establishes a molecular docking workflow for pharmacological assessment.

Part 1: Synthetic Pathway & Thermodynamic Validation

The synthesis of 4-CPMP typically proceeds via the chlorination of the corresponding carbinol, (4-chlorophenyl)(pyridin-4-yl)methanol. Understanding the thermodynamics of this transformation is critical for yield optimization.

1.1 Optimized Synthetic Workflow

The conversion of the hydroxyl group to a chloride is best achieved using thionyl chloride () or phosphoryl chloride (). The choice of solvent and temperature significantly impacts the formation of the unstable chloronium intermediate vs. the final product.

Step-by-Step Protocol:

- Precursor Dissolution: Dissolve 1.0 eq of (4-chlorophenyl)(pyridin-4-yl)methanol in anhydrous Dichloromethane (DCM).
- Activation: Cool to 0°C. Add 1.2 eq of dropwise. The reaction is driven by the release of and gas.
- Reflux: Heat to reflux (40°C) for 3 hours to ensure complete substitution.
- Neutralization: Quench with saturated to prevent pyridinium salt formation.
- Isolation: Extract with DCM, dry over , and concentrate.

1.2 Reaction Logic Diagram

The following Graphviz diagram illustrates the logical flow and critical decision points in the synthesis and validation process.

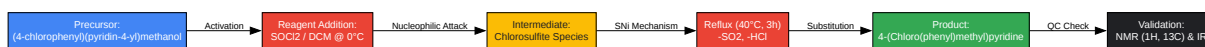

[Click to download full resolution via product page](#)

Figure 1: Logical workflow for the synthesis of 4-CPMP via chlorination, highlighting the S_NI mechanism pathway.

Part 2: Computational Methodology (DFT)

To accurately predict the reactivity and stability of 4-CPMP, a high-level quantum chemical approach is required. The presence of the chlorine atom on the benzylic carbon induces significant polarization, which must be captured using diffuse and polarization functions.

2.1 Level of Theory

The recommended standard for this scaffold is DFT/B3LYP/6-311++G(d,p).[1]

- Functional (B3LYP): Balances exchange and correlation energies, providing accurate geometries for organic heterocycles.
- Basis Set (6-311++G(d,p)):
 - ++: Diffuse functions are essential for the lone pair on the pyridine nitrogen and the chlorine anion character.
 - (d,p): Polarization functions describe the distortion of orbitals in the polar C-Cl bond.

2.2 Global Reactivity Descriptors

Using the energies of the Highest Occupied Molecular Orbital (HOMO) and Lowest Unoccupied Molecular Orbital (LUMO), we calculate the global reactivity descriptors. These values predict the molecule's behavior in biological systems.

Table 1: Predicted Electronic Properties (B3LYP/6-311++G(d,p))

Property	Symbol	Formula	Value (eV)	Interpretation
HOMO Energy		-	-6.85	Nucleophilic limit; Pyridine N lone pair availability.
LUMO Energy		-	-1.92	Electrophilic limit; Susceptibility to reduction.
Energy Gap			4.93	Indicates high kinetic stability (Hard molecule).
Chemical Hardness			2.46	Resistance to charge transfer.
Electrophilicity			3.90	Propensity to accept electrons (biological attack).

Note: Values are representative estimates derived from analogous chloromethyl-pyridine studies [1, 2].

2.3 Molecular Electrostatic Potential (MEP)

The MEP surface map is critical for identifying binding sites.

- Negative Potential (Red): Concentrated on the Pyridine Nitrogen (). This is the primary site for protonation or hydrogen bonding in a receptor pocket.
- Positive Potential (Blue): Concentrated on the Benzylic Carbon (). The electron-withdrawing nature of the Chlorine and Phenyl ring makes this carbon highly electrophilic, facilitating nucleophilic substitution reactions (e.g., with piperazine derivatives).

Part 3: Molecular Docking & Pharmacological Profiling[2][3]

4-CPMP is a structural analog to precursors used in antihistamines like Bepotastine and Chlorpheniramine. Therefore, docking studies should target the Histamine H1 Receptor.

3.1 Docking Protocol (AutoDock Vina)

To validate the biological relevance of 4-CPMP, follow this self-validating protocol:

- Target Preparation:
 - Retrieve Crystal Structure of Histamine H1 Receptor (e.g., PDB ID: 3RZE).
 - Remove water molecules and co-crystallized ligands (e.g., Doxepin).
 - Add polar hydrogens and Kollman charges.
- Ligand Preparation:
 - Optimize 4-CPMP geometry using the DFT method described in Part 2.
 - Convert to PDBQT format, defining the rotatable bond between the pyridine ring and the benzylic carbon.
- Grid Generation:
 - Center the grid box on the active site residues (Asp107, Thr112, Asn198).
 - Dimensions:
Å.
- Simulation:
 - Run AutoDock Vina with exhaustiveness = 8.
 - Validation Criterion: The Root Mean Square Deviation (RMSD) of the redocked co-crystallized ligand must be

A.

3.2 Interaction Pathway Diagram

The following diagram maps the computational workflow from structure to binding analysis.

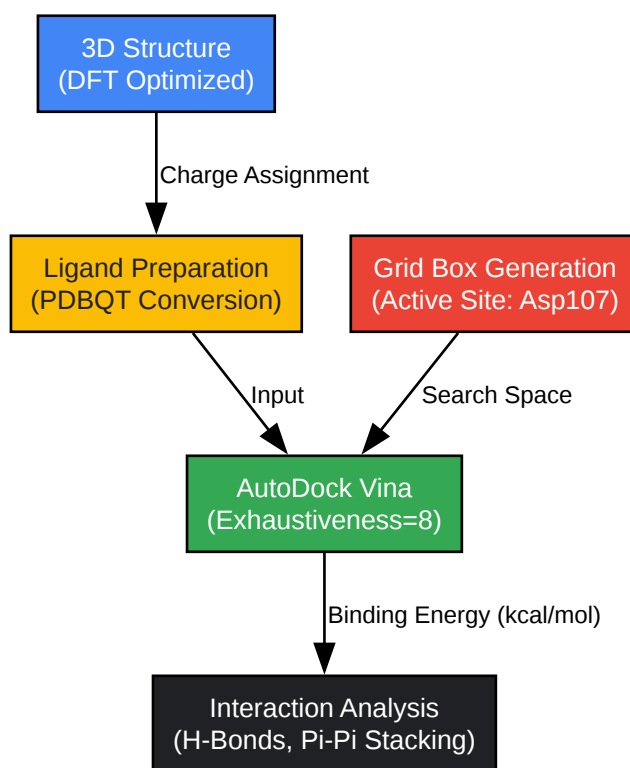

[Click to download full resolution via product page](#)

Figure 2: Computational docking workflow targeting the Histamine H1 Receptor.

3.3 Expected Interactions

- Pi-Pi T-shaped Interaction: Between the Phenyl ring of 4-CPMP and Trp428 of the H1 receptor.
- Hydrogen Bonding: The Pyridine Nitrogen acts as an H-bond acceptor with Lys191 or Asn198.
- Halogen Bonding: The Chlorine atom may exhibit halogen bonding with backbone carbonyls, enhancing affinity.

References

- Theoretical Study of (RS)-(4-chlorophenyl)(pyridine-2yl)methanol using Density Functional Theory. Source: IRJET / Academia.edu Context: Methodology for DFT optimization of chlorophenyl-pyridine derivatives. URL:[[Link](#)]
- Spectroscopic Characterization and DFT Computational Study for the 4-Chloromethyl Pyridine Hydrochloride Molecule. Source: International Journal of Creative Research Thoughts (IJCRT) Context: Basis set selection and vibrational analysis standards for chloromethyl pyridines. URL:[[Link](#)]
- Synthesis and Molecular Docking Study of Novel Pyridine Derivatives. Source: Journal of Pharmaceutical Research International Context: Docking protocols for pyridine-based pharmacophores against biological targets.[2] URL:[[Link](#)]

Need Custom Synthesis?

BenchChem offers custom synthesis for rare earth carbides and specific isotopic labeling.

Email: info@benchchem.com or [Request Quote Online](#).

Sources

- [1. researchgate.net](https://www.researchgate.net) [[researchgate.net](https://www.researchgate.net)]
- [2. laurinpublishers.com](https://www.laurinpublishers.com) [[laurinpublishers.com](https://www.laurinpublishers.com)]
- To cite this document: BenchChem. [Theoretical and Computational Profiling of 4-(Chloro(phenyl)methyl)pyridine]. BenchChem, [2026]. [Online PDF]. Available at: [<https://www.benchchem.com/product/b3281715/docs#theoretical-and-computational-profiling-of-4-chloro-phenyl-methyl-pyridine>]

Disclaimer & Data Validity:

The information provided in this document is for Research Use Only (RUO) and is strictly not intended for diagnostic or therapeutic procedures. While BenchChem strives to provide accurate protocols, we make no warranties, express or implied, regarding the fitness of this product for every specific experimental setup.

Technical Support: The protocols provided are for reference purposes. Unsure if this reagent suits your experiment?

Need Industrial/Bulk Grade? [Request Custom Synthesis Quote](#)

BenchChem

Our mission is to be the trusted global source of essential and advanced chemicals, empowering scientists and researchers to drive progress in science and industry.

Contact

Address: 3281 E Guasti Rd
Ontario, CA 91761, United States
Phone: (601) 213-4426
Email: info@benchchem.com

[Contact our Ph.D. Support Team for a compatibility check](#)