

Technical Guide: Resolving Amide Rotamers in 1-Benzoylpiperidin-3-ol

Author: BenchChem Technical Support Team. **Date:** April 2026

Compound of Interest

Compound Name: 1-Benzoylpiperidin-3-ol

CAS No.: 67452-86-2

Cat. No.: B3278243

[Get Quote](#)

Diagnostic: Impurity vs. Rotamer[1]

The Issue: You have synthesized or purchased **1-benzoylpiperidin-3-ol**. The

¹H NMR spectrum at room temperature (298 K) in CDCl₃

shows doubled peaks, broad "humps," or fractional integration values (e.g., 0.6H and 0.4H) that do not match a single pure compound.

The Cause: The amide bond (

) possesses partial double-bond character due to resonance.[1] This restricts rotation, creating two distinct conformers (rotamers) that interconvert slowly on the NMR timescale at room temperature. For 3-substituted piperidines, this often results in a ~60:40 to 75:25 mixture of syn and anti rotamers.[1]

Quick Diagnostic Checklist

Observation	Likely Cause	Action
Ratio: Peaks appear in a consistent non-integer ratio (e.g., 2:1 or 3:2) across the entire spectrum.	Rotamers	Proceed to Protocol A (VT-NMR).
Ratio: Ratio varies (e.g., aromatic region is 1:1, aliphatic is 9:1).	Impurity	Repurify (Chromatography).[1]
Shape: Peaks are broad/undefined blobs at 25°C but sharpen when cooled or heated.[1]	Rotamers	Exchange rate is "intermediate." [1] Alter Temp.
Exchange: 1D NOE irradiation of Peak A causes saturation transfer to Peak B.	Rotamers	Confirmed chemical exchange. [1]

The Physics of the Problem

To solve the spectral complexity, one must understand the equilibrium. The nitrogen lone pair donates into the carbonyl

-system, creating a barrier to rotation (

).

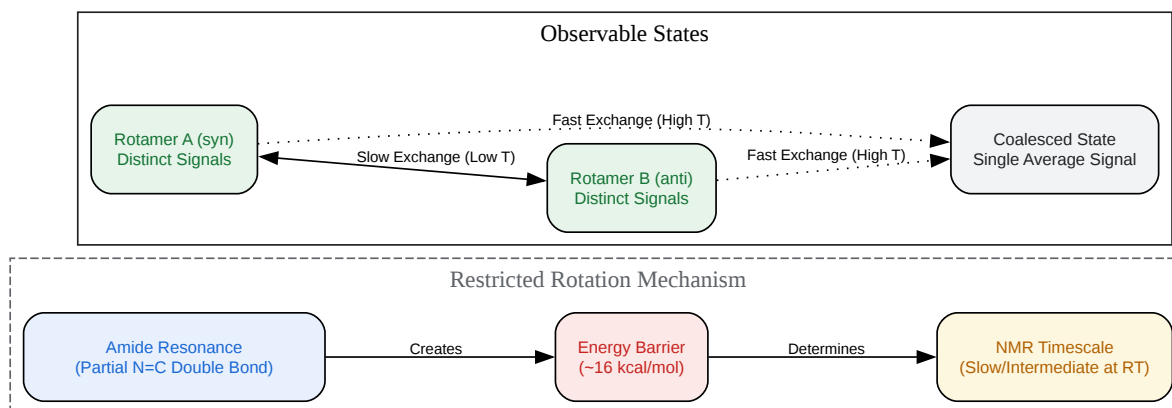

[Click to download full resolution via product page](#)

Figure 1: Mechanistic pathway of amide rotamerism affecting NMR observables.

Resolution Protocols

Protocol A: High-Temperature Coalescence (Recommended for Purity Check)

Heating the sample increases the rate of rotation.[1] Once the exchange rate (

) exceeds the frequency difference between rotamers (

), the signals merge (coalesce) into a single, sharp set. This is the standard method to prove purity.

- Solvent: DMSO-

(Boiling Point: 189°C) is ideal. Avoid CDCl

(BP: 61°C) as it cannot reach coalescence temperatures safely.

- Target Temperature: Typically 353 K to 373 K (80°C to 100°C).[1]

Step-by-Step:

- Prepare Sample: Dissolve ~5-10 mg of **1-benzoylpiperidin-3-ol** in 0.6 mL DMSO-

.

- Initial Scan: Acquire a standard

¹H spectrum at 298 K (25°C).[1] Note the doubled peaks (especially the

-

protons at 3.0–4.5 ppm).[1]

- Stepwise Heating:
 - Increase probe temperature to 323 K (50°C). Allow 5 mins for equilibration. Shim and acquire.[1]
 - Increase to 343 K (70°C). Shim and acquire.[1]
 - Increase to 373 K (100°C).[2] Shim and acquire.[1]
- Analysis: At 373 K, the doubled peaks should collapse into single, sharp multiplets. Integration will now perfectly match the formula C

H

NO

.

Troubleshooting High-T Experiments:

- Issue: Peaks are still broad at 100°C.
- Solution: The energy barrier is high. If your probe allows, go to 120°C (393 K) in DMSO. Alternatively, switch to a lower field instrument (e.g., 300 MHz vs 600 MHz); coalescence occurs at lower temperatures on lower field magnets because

(in Hz) is smaller.

Protocol B: Low-Temperature Separation (Recommended for Structural Assignment)

If you need to assign specific protons (e.g., determining the stereochemistry at C3), high-temperature averaging destroys coupling information. Instead, cool the sample to "freeze" the rotation, obtaining sharp, distinct integrals for both rotamers.

- Solvent: CD

Cl

(Freezes < -95°C) or Acetone-

[.1](#)

- Target Temperature: 233 K to 253 K (-40°C to -20°C).

Step-by-Step:

- Prepare Sample: Dissolve in CD

Cl

or CDCl

(if not going below -50°C).

- Cooling: Lower temperature to -20°C.
- Shim: Shimming is critical at low T due to viscosity changes.[1](#)
- Result: You will see two distinct sets of sharp signals. You can now integrate the major rotamer (e.g., 1.0H) and minor rotamer (e.g., 0.5H) separately to confirm the structure.

Advanced Verification: EXSY / 1D NOE

If VT-NMR is unavailable, use chemical exchange spectroscopy to prove the two species are communicating.

Experiment: 1D Selective NOE (or 1D EXSY).

- Select Targets: Identify two distinct peaks suspected to be the same proton in different rotamers (e.g., the methine proton at C3).
- Irradiate: Selectively irradiate the major rotamer peak.[1]
- Observe: Look for a negative NOE signal (saturation transfer) at the frequency of the minor rotamer peak.
 - Positive NOE = Spatial proximity (dipolar coupling).[1]
 - Negative NOE / Saturation Transfer = Chemical exchange (same proton moving between environments).[1]

Summary Data Table

Variable	Condition	Effect on 1-Benzoylpiperidin-3-ol Spectrum
Solvent: CDCl	Non-polar	Maximizes H-bonding difference; rotamers often distinct but broad.[1]
Solvent: DMSO-	Polar Aprotic	Lowers rotation barrier slightly; high BP allows coalescence.[1]
Temp: High (>80°C)	Fast Exchange	Simplification: Spectra merge into one set.[1] Best for purity.
Temp: Low (<-20°C)	Slow Exchange	Resolution: Sharp signals for both isomers.[1] Best for assignment.
Field Strength	High (e.g., 800 MHz)	Harder to coalesce (requires higher T). Better for Low-T separation.

References

- Mechanisms of Amide Rotamerism
 - Dynamic NMR Spectroscopy.[1][3][4] Sandström, J. (1982). Academic Press.[1] (Foundational text on chemical exchange).
 - Rotamers or Diastereomers? An Overlooked NMR Solution. Hu, D. X., Grice, P., & Ley, S. V. (2012). The Journal of Organic Chemistry, 77(11), 5198–5202.
- Piperidine Ring Dynamics & N-Acyl Deriv
 - NMR-based investigations of acyl-functionalized piperazines concerning their conformational behavior in solution. Wiglenda, T., et al. (2018). RSC Advances, 8, 159-168.[1]
- Variable Temper
 - Variable Temperature NMR Experiment Studying Restricted Bond Rotation. Le, K. N., et al. (2020).

Need Custom Synthesis?

BenchChem offers custom synthesis for rare earth carbides and specific isotopic labeling.

Email: info@benchchem.com or [Request Quote Online](#).

Sources

- [1. chemscene.com](https://chemscene.com) [chemscene.com]
- [2. nmr.chem.ox.ac.uk](https://nmr.chem.ox.ac.uk) [nmr.chem.ox.ac.uk]
- [3. semanticscholar.org](https://www.semanticscholar.org) [semanticscholar.org]
- [4. NMR-based investigations of acyl-functionalized piperazines concerning their conformational behavior in solution - PMC](https://pubmed.ncbi.nlm.nih.gov/3278243/) [pmc.ncbi.nlm.nih.gov]
- To cite this document: BenchChem. [Technical Guide: Resolving Amide Rotamers in 1-Benzoylpiperidin-3-ol]. BenchChem, [2026]. [Online PDF]. Available at: [<https://www.benchchem.com/product/b3278243/docs#technical-guide-resolving-amide-rotamers-in-1-benzoylpiperidin-3-ol>]

Disclaimer & Data Validity:

The information provided in this document is for Research Use Only (RUO) and is strictly not intended for diagnostic or therapeutic procedures. While BenchChem strives to provide accurate protocols, we make no warranties, express or implied, regarding the fitness of this product for every specific experimental setup.

Technical Support: The protocols provided are for reference purposes. Unsure if this reagent suits your experiment?

Need Industrial/Bulk Grade? [Request Custom Synthesis Quote](#)

BenchChem

Our mission is to be the trusted global source of essential and advanced chemicals, empowering scientists and researchers to drive progress in science and industry.

Contact

Address: 3281 E Guasti Rd
Ontario, CA 91761, United States
Phone: (601) 213-4426
Email: info@benchchem.com

[Contact our Ph.D. Support Team for a compatibility check](#)