

Demethylation protocols for converting methoxy groups to phenols in diarylethanes

Author: BenchChem Technical Support Team. **Date:** April 2026

Compound of Interest

Compound Name: *1-Bromo-4-(1-(4-methoxyphenyl)ethyl)benzene*

CAS No.: 65699-87-8

Cat. No.: B3277258

[Get Quote](#)

Application Notes & Protocols

Topic: Advanced Demethylation Protocols: A Guide to Converting Methoxy Groups to Phenols in Diarylethane Scaffolds

For: Researchers, Scientists, and Drug Development Professionals

Strategic Overview: The Critical Role of Methoxy-to-Phenol Conversion

The transformation of a methoxy group (O-CH₃) into a phenolic hydroxyl group (-OH) on an aromatic ring is a cornerstone of synthetic and medicinal chemistry. Within the context of diarylethane frameworks—structures prevalent in numerous biologically active molecules and pharmaceutical agents—this conversion holds particular strategic importance. The aryl methyl ether is a robust protecting group, stable under a wide array of reaction conditions, making it an ideal choice during complex multi-step syntheses.^[1] However, the ultimate biological activity of a molecule often hinges on the presence of a free phenol.

Why is this demethylation step so crucial?

- **Pharmacological Activity:** A phenolic hydroxyl can act as a critical hydrogen bond donor and acceptor, forming key interactions with biological targets like enzymes and receptors. This can dramatically enhance binding affinity and, consequently, the drug's efficacy.
- **Metabolic Profiling:** Converting a methoxy group to a phenol can alter a drug candidate's metabolic pathway, often creating a site for Phase II conjugation (e.g., glucuronidation), which impacts its pharmacokinetic profile, including clearance and half-life.
- **Synthetic Handle:** A phenol is a versatile functional group, serving as a nucleophile for subsequent derivatization through etherification, esterification, or other coupling reactions, enabling the generation of diverse compound libraries for structure-activity relationship (SAR) studies.

Despite its importance, the cleavage of the strong aryl C-O bond is not trivial and requires carefully selected reagents and conditions to avoid unwanted side reactions, especially on complex diarylethane substrates. This guide provides a detailed examination of the mechanisms, reagents, and step-by-step protocols for achieving this transformation efficiently and selectively.

Mechanistic Insights & Reagent Selection

The cleavage of aryl methyl ethers typically proceeds via an SN2 reaction where a nucleophile attacks the methyl carbon, and the aryloxy group acts as the leaving group. The efficiency of this process is dictated by the strength of the nucleophile and the activation of the ether oxygen. Reagents can be broadly categorized into Lewis acids, strong protic acids, and nucleophilic systems.

The Workhorse Reagent: Boron Tribromide (BBr₃)

Boron tribromide is arguably the most widely used and effective reagent for aryl ether demethylation, functioning efficiently even at or below room temperature.^{[2][3]} Its power lies in its strong Lewis acidity.

Mechanism of BBr₃ Demethylation:

- **Lewis Acid Adduct Formation:** The highly electrophilic boron atom coordinates to the ether oxygen, forming a Lewis acid-base complex.^[2] This complexation activates the ether, making the methyl group more susceptible to nucleophilic attack.
- **Nucleophilic Attack:** A bromide ion, either from another BBr_3 molecule or from the dissociation of the initial adduct, acts as a nucleophile. It attacks the methyl carbon in an $\text{S}_\text{N}2$ fashion.^{[4][5]}
- **Intermediate Formation:** This attack cleaves the C-O bond, generating methyl bromide (CH_3Br) and an aryloxydibromoborane intermediate (Ar-O-BBr_2).^[2]
- **Hydrolysis:** Upon aqueous workup, the aryloxydibromoborane is hydrolyzed to yield the final phenol, along with boric acid and hydrobromic acid.^[2]

Recent computational studies suggest a more complex mechanism where one equivalent of BBr_3 can theoretically cleave up to three equivalents of an aryl methyl ether, proceeding through charged intermediates and producing triphenoxyborane before hydrolysis.^{[4][6]}

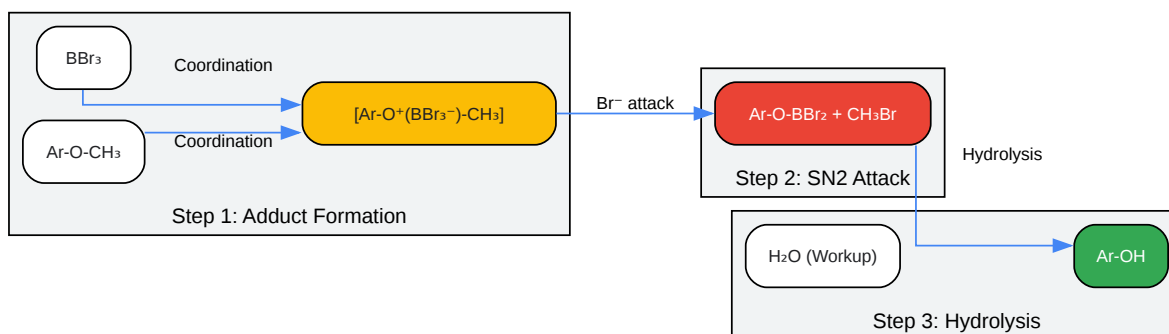

Figure 1: BBr_3 Demethylation Mechanism

[Click to download full resolution via product page](#)

Caption: Figure 1: BBr_3 Demethylation Mechanism

Comparative Analysis of Demethylation Reagents

Choosing the right reagent is critical and depends on the substrate's functional group tolerance, steric hindrance, and desired reaction conditions.

Reagent System	Typical Conditions	Mechanism Type	Advantages	Disadvantages
Boron Tribromide (BBr ₃)	CH ₂ Cl ₂ , -78°C to RT[7][8]	Lewis Acid-Assisted SN2	Highly effective, reliable, works at low temperatures, well-documented.[3][9]	Highly corrosive and moisture-sensitive, can be non-selective with multiple reactive sites.[5][8]
Hydrobromic Acid (HBr)	48% aq. HBr, often with additives, reflux[10][11]	Protic Acid-Assisted SN2	Inexpensive, powerful.	Harsh conditions (high temp), not suitable for acid-sensitive substrates, potential for ring bromination.[10]
Iodotrimethylsilane (TMSI)	CHCl ₃ or CH ₃ CN, RT to 50°C[8]	SN2-type	Milder than BBr ₃ , often generated in situ from TMSCl and Ial for cost and stability.[12][13]	Reagent can be expensive and unstable, organoiodine byproducts.[13]
L-Selectride®	THF, reflux[14]	Nucleophilic	Excellent for substrates with acid-labile groups, can show chemoselectivity.[15][16]	Strongly basic, requires anhydrous conditions, may reduce other functional groups.

Thiolates (e.g., NaSEt, Dodecanethiolate)	DMF or NMP, reflux	Nucleophilic SN2	Non-acidic, useful for specific substrates.[1]	Malodorous reagents, high temperatures often required, potential for side reactions.
Microwave-Assisted (Ionic Liquid or Acid)	Microwave reactor, 15s to 60 min[1][17]	Varies (SN2)	Extremely rapid reaction times, improved yields, "green chemistry" approach.[18][19]	Requires specialized equipment, potential for decomposition with excessive power.[1]

Detailed Experimental Protocols

The following protocols are designed to be self-validating, with clear steps and explanations for critical operations. Safety Precaution: Always work in a well-ventilated fume hood and wear appropriate personal protective equipment (PPE), including safety glasses, lab coat, and chemical-resistant gloves.

Protocol 1: Classic Demethylation using Boron Tribromide (BBr₃)

This protocol is the industry standard for its reliability and effectiveness across a wide range of diarylethane substrates.[3][9]

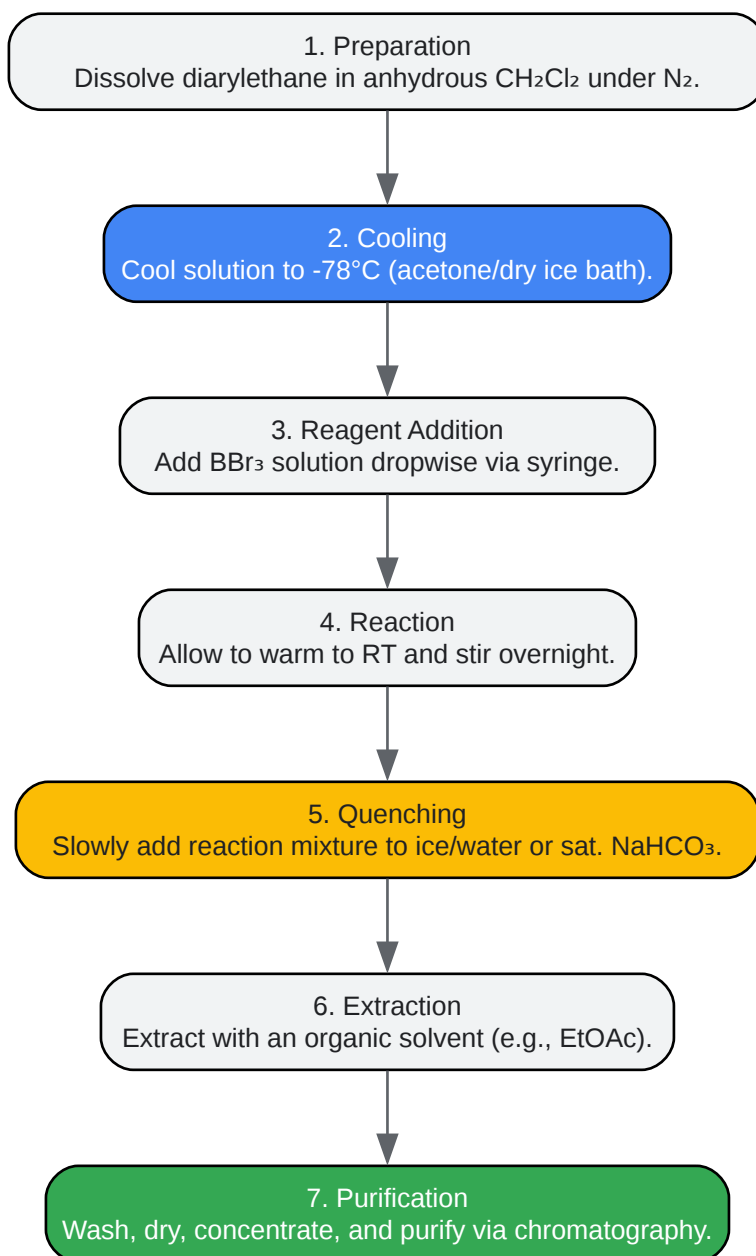

Figure 2: BBr₃ Demethylation Workflow

[Click to download full resolution via product page](#)

Caption: Figure 2: BBr₃ Demethylation Workflow

Materials:

- Methoxy-substituted diarylethane (1.0 equiv)
- Anhydrous Dichloromethane (CH₂Cl₂)

- Boron tribromide (BBr_3), 1.0 M solution in CH_2Cl_2
- Saturated aqueous sodium bicarbonate (NaHCO_3) or water
- Ethyl acetate (EtOAc) or other suitable extraction solvent
- Anhydrous magnesium sulfate (MgSO_4) or sodium sulfate (Na_2SO_4)
- Round-bottom flask, magnetic stirrer, nitrogen inlet, syringe, acetone/dry ice bath

Step-by-Step Methodology:

- **Reaction Setup:** To a flame-dried round-bottom flask under a nitrogen atmosphere, add the methoxy-substituted diarylethane (1.0 equiv). Dissolve it in anhydrous CH_2Cl_2 (approx. 0.1-0.2 M concentration).
- **Cooling:** Cool the stirred solution to $-78\text{ }^\circ\text{C}$ using an acetone/dry ice bath.[9] A white precipitate may form if the substrate's solubility is low at this temperature.
- **Reagent Addition:** Slowly add the BBr_3 solution (1.2 equivalents per methoxy group) dropwise via a syringe over 10-15 minutes.[7]
 - **Causality:** A slow, cold addition is critical to control the initial exothermic reaction between the Lewis acid and the ether. It prevents localized heating and potential side reactions. It is advisable to use one mole of BBr_3 per ether group, plus an extra mole for any other potentially basic groups in the molecule (e.g., carbonyl, nitrile).[3]
- **Reaction Progression:** After the addition is complete, remove the cooling bath and allow the reaction mixture to slowly warm to room temperature. Let it stir overnight (12-18 hours). Monitor the reaction progress by TLC or LC-MS.
- **Quenching:** Carefully and slowly pour the reaction mixture into a separate flask containing a vigorously stirred mixture of crushed ice and water or saturated NaHCO_3 solution.
 - **Trustworthiness:** This step hydrolyzes the aryloxydibromoborane intermediate and neutralizes the excess BBr_3 and generated HBr . [9] Performing this addition slowly and into

a well-stirred solution is a crucial safety measure to manage the vigorous and exothermic hydrolysis of BBr_3 .

- Extraction: Transfer the quenched mixture to a separatory funnel. Extract the aqueous layer three times with EtOAc. Combine the organic layers.
- Workup and Purification: Wash the combined organic layers with brine, dry over anhydrous MgSO_4 , filter, and concentrate under reduced pressure. The resulting crude phenol can be purified by flash column chromatography on silica gel.

Protocol 2: Microwave-Assisted Demethylation with an Ionic Liquid

This protocol offers a green, rapid, and often high-yielding alternative to classical methods, leveraging the efficient heating of ionic liquids by microwave irradiation.[1][18]

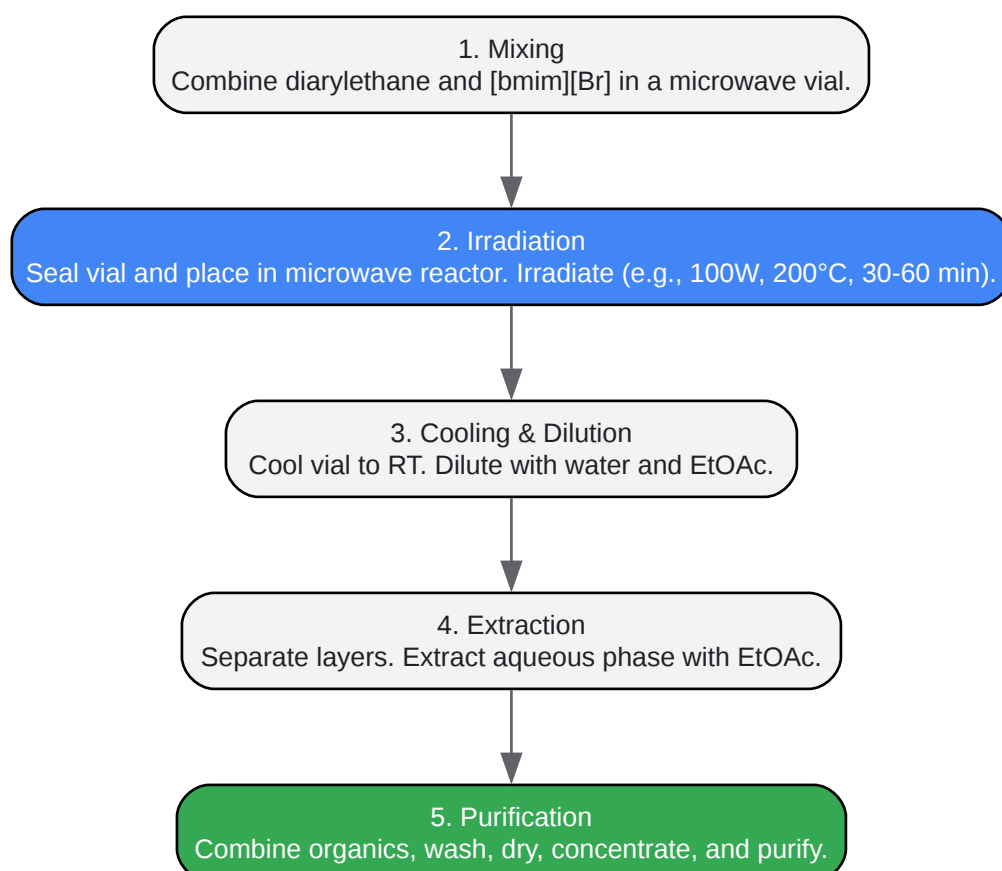

Figure 3: Microwave Demethylation Workflow

[Click to download full resolution via product page](#)

Caption: Figure 3: Microwave Demethylation Workflow

Materials:

- Methoxy-substituted diarylethane (1.0 equiv)
- 1-Butyl-3-methylimidazolium bromide ([bmim][Br]) (3.0 equiv)[1]
- Microwave synthesis reactor with sealed vessel capability
- Water, Ethyl acetate (EtOAc)

Step-by-Step Methodology:

- Preparation: In a dedicated microwave reaction vessel, combine the methoxy-substituted diarylethane (1.0 equiv) and [bmim][Br] (3.0 equiv). No additional solvent is required as the ionic liquid serves as both the cleaving nucleophile and the solvent.[1]
- Microwave Irradiation: Seal the vessel and place it in the microwave reactor. Irradiate the mixture with a set temperature control (e.g., 200 °C) for 30-60 minutes.
 - Causality: Microwave irradiation is crucial for this method's success; conventional heating is much less effective.[1][18] The ionic liquid's high dielectric properties allow it to absorb microwave energy efficiently, leading to rapid and uniform heating that drives the reaction. Power should be kept low (e.g., fluctuating below 100 W) to prevent decomposition and tar formation.[1]
- Workup: After the reaction is complete, cool the vessel to room temperature. Dilute the mixture with water and extract with EtOAc.
- Extraction and Purification: Separate the layers. The ionic liquid will preferentially partition into the aqueous phase. Extract the aqueous layer two more times with EtOAc. Combine the organic layers, wash with brine, dry over anhydrous Na₂SO₄, filter, and concentrate. Purify the product by flash chromatography.
 - Trustworthiness: This simple extraction removes the ionic liquid, which is a key advantage of this protocol, simplifying purification and making it a more attractive "green" process.[1]

References

- Microwave-Assisted Demethylation of Methyl Aryl Ethers Using an Ionic Liquid. SYNLETT, 2010.
- Demethyl
- Rapid microwave-assisted cleavage of methyl phenyl ethers: new method for synthesizing demethyl precursors and for removing pro. Journal of Labelled Compounds and Radiopharmaceuticals, 2002.
- demethylation of aryl methyl ethers by. Tetrahedron, 1967.
- 3,3'-DIHYDROXYBIPHENYL. Organic Syntheses, 1969.
- Ether Cleavage Re-Investigated: Elucidating the Mechanism of BBr₃-Facilitated Demethyl
- Demethylation of Methyl Ethers - Boron Tribromide (BBr₃). Common Organic Chemistry.
- ChemInform Abstract: Microwave-Assisted Demethylation of Methyl Aryl Ethers Using an Ionic Liquid.
- Demethylation of aryl methyl ethers using pyridinium p -toluenesulfonate under microwave irradiation.
- Aryl methyl ether cleavage. Reddit, 2022.
- IODOTRIMETHYLSILANE. Organic Syntheses.
- A Comparative Guide to Ether Cleavage Reagents. Benchchem, 2025.
- Ether Cleavage Re-Investigated: Elucidating the Mechanism of BBr₃-Facilitated Demethylation of Aryl Methyl Ethers. PubMed, 2015.
- Selective Cleavage of Aryl Methyl Ether Moiety of Aryloxy Aryl Methyl Ether by 48% HBr/Tetra-n-butylphosphonium Bromide.
- Chemoselective Demethylation of Methoxypyridines over Anisoles. Synlett, 2019.
- Methods of O-demethylation and N-deprotection.
- L-Selectride as a General Reagent for the O-Demethylation and N-Decarbomethoxylation of Opium Alkaloids and Derivatives. Washington University School of Medicine, 1998.
- Demethylation of Mitragynine Picrate with BBr₃ and C₁₂H₂₅-SH /NaOMe: A new entry for Ester Derivatives Preparation based on Position Carbon 9. Asian Journal of Research in Chemistry, 2018.
- Trimethylsilyl Iodide (TMSI). ACS GCI Pharmaceutical Roundtable Reagent Guides.

Need Custom Synthesis?

BenchChem offers custom synthesis for rare earth carbides and specific isotopic labeling.

Email: info@benchchem.com or [Request Quote Online](#).

Sources

- [1. Thieme E-Journals - Synlett / Abstract \[thieme-connect.com\]](#)
- [2. gktoday.in \[gktoday.in\]](#)
- [3. chemistry.mdma.ch \[chemistry.mdma.ch\]](#)
- [4. Ether Cleavage Re-Investigated: Elucidating the Mechanism of BBr₃-Facilitated Demethylation of Aryl Methyl Ethers - PMC \[pmc.ncbi.nlm.nih.gov\]](#)
- [5. ajrconline.org \[ajrconline.org\]](#)
- [6. Ether Cleavage Re-Investigated: Elucidating the Mechanism of BBr₃-Facilitated Demethylation of Aryl Methyl Ethers - PubMed \[pubmed.ncbi.nlm.nih.gov\]](#)
- [7. Demethylation of Methyl Ethers - Boron Tribromide \(BBr₃\) \[commonorganicchemistry.com\]](#)
- [8. benchchem.com \[benchchem.com\]](#)
- [9. Organic Syntheses Procedure \[orgsyn.org\]](#)
- [10. reddit.com \[reddit.com\]](#)
- [11. tandfonline.com \[tandfonline.com\]](#)
- [12. Organic Syntheses Procedure \[orgsyn.org\]](#)
- [13. Trimethylsilyl Iodide \(TMSI\) - Wordpress \[reagents.acscipr.org\]](#)
- [14. US6395900B1 - Methods of O-demethylation and N-deprotection - Google Patents \[patents.google.com\]](#)
- [15. Thieme E-Journals - Synfacts / Abstract \[thieme-connect.com\]](#)
- [16. profiles.wustl.edu \[profiles.wustl.edu\]](#)
- [17. chemistry.mdma.ch \[chemistry.mdma.ch\]](#)
- [18. researchgate.net \[researchgate.net\]](#)
- [19. researchgate.net \[researchgate.net\]](#)
- [To cite this document: BenchChem. \[Demethylation protocols for converting methoxy groups to phenols in diarylethanes\]. BenchChem, \[2026\]. \[Online PDF\]. Available at: \[https://www.benchchem.com/product/b3277258/docs#demethylation-protocols-for-converting-methoxy-groups-to-phenols-in-diarylethanes\]](#)

Disclaimer & Data Validity:

The information provided in this document is for Research Use Only (RUO) and is strictly not intended for diagnostic or therapeutic procedures. While BenchChem strives to provide accurate protocols, we make no warranties, express or implied, regarding the fitness of this product for every specific experimental setup.

Technical Support: The protocols provided are for reference purposes. Unsure if this reagent suits your experiment?

Need Industrial/Bulk Grade? [Request Custom Synthesis Quote](#)

BenchChem

Our mission is to be the trusted global source of essential and advanced chemicals, empowering scientists and researchers to drive progress in science and industry.

Contact

Address: 3281 E Guasti Rd
Ontario, CA 91761, United States
Phone: (601) 213-4426
Email: info@benchchem.com

[Contact our Ph.D. Support Team for a compatibility check](#)