

Validating the Binding of 4-Mercaptobenzamide to Gold Nanoparticles: A Comparative Guide

Author: BenchChem Technical Support Team. **Date:** December 2025

Compound of Interest

Compound Name: 4-Mercaptobenzamide

Cat. No.: B3273640

[Get Quote](#)

For researchers, scientists, and drug development professionals, the functionalization of gold nanoparticles (AuNPs) is a critical step in the development of novel diagnostic and therapeutic agents. **4-Mercaptobenzamide** (4-MBA) is a commonly used surface ligand, binding to AuNPs through a stable gold-thiol bond. This guide provides a comprehensive overview of the experimental techniques used to validate this binding, offering a comparison with other thiol-containing molecules and presenting detailed experimental protocols.

The interaction between the sulfur atom of the thiol group in 4-MBA and the gold surface forms a strong, covalent-like bond, leading to the formation of a self-assembled monolayer (SAM). This functionalization is crucial for the stability of the nanoparticles in solution and for subsequent conjugation with other biomolecules. The validation of this binding is paramount to ensure the successful construction of nanoparticle-based systems.

Comparative Analysis of Thiol-Gold Nanoparticle Binding

The stability and nature of the bond between a thiol-containing molecule and a gold nanoparticle surface can be influenced by several factors, including the structure of the thiol molecule and the surrounding environment. While 4-MBA forms a robust bond, other thiols exhibit different binding characteristics.

Feature	4-Mercaptobenzamide (4-MBA)	Alkanethiols (e.g., 1-dodecanethiol)	Thiolated DNA
Binding Moiety	Aromatic thiol	Aliphatic thiol	Thiol group at the terminus of an oligonucleotide
Binding Affinity	High	High	High
SAM Packing	Ordered, influenced by pi-pi stacking of aromatic rings	Densely packed, ordered alkyl chains	Less dense packing due to steric hindrance of the DNA backbone
Evidence of Binding	Disappearance of S-H Raman peak, Au-S bond confirmation by XPS, red-shift in LSPR.	Disappearance of S-H Raman peak, Au-S bond confirmation by XPS, red-shift in LSPR.	Hybridization assays, gel electrophoresis, and spectroscopic methods.
Key Characteristics	Provides a functionalizable aromatic ring on the surface.	Creates a hydrophobic surface.	Enables the attachment of specific DNA sequences for biosensing applications.

Experimental Validation of 4-MBA Binding to Gold Nanoparticles

A multi-faceted approach employing several analytical techniques is essential to unequivocally confirm the binding of 4-MBA to AuNPs.

Surface-Enhanced Raman Spectroscopy (SERS)

SERS is a highly sensitive technique for detecting molecules adsorbed on noble metal surfaces. The binding of 4-MBA to AuNPs results in a characteristic SERS spectrum.

Key Observations:

- Disappearance of the S-H stretching band: The Raman peak corresponding to the S-H bond, typically around 2560 cm^{-1} , disappears upon the formation of the Au-S bond.
- Enhancement of aromatic ring vibrations: The vibrational modes of the benzene ring of 4-MBA are significantly enhanced. Prominent peaks are typically observed around 1077 cm^{-1} and 1586 cm^{-1} [1].

Quantitative Analysis: SERS Enhancement Factor (EF)

The SERS EF quantifies the enhancement of the Raman signal. It can be calculated using the following formula:

$$EF = (ISERS / NSERS) / (IRaman / NRaman)$$

Where:

- ISERS is the intensity of a specific Raman band in the SERS spectrum.
- NSERS is the number of molecules adsorbed on the SERS-active surface.
- IRaman is the intensity of the same Raman band in a non-enhanced Raman spectrum.
- NRaman is the number of molecules in the scattering volume of the non-enhanced measurement.

X-ray Photoelectron Spectroscopy (XPS)

XPS is a surface-sensitive technique that provides information about the elemental composition and chemical states of the elements on the nanoparticle surface.

Key Observations:

- Au 4f peaks: The characteristic doublet of Au 4f_{7/2} and Au 4f_{5/2} will be observed. A slight shift in the binding energy of the surface gold atoms may be detected upon 4-MBA binding.
- S 2p peak: The appearance of a peak in the S 2p region is direct evidence of the presence of sulfur on the nanoparticle surface, confirming the binding of 4-MBA. The binding energy of the S 2p peak can indicate the formation of a gold-thiolate bond.

UV-Visible Spectroscopy

UV-Vis spectroscopy is used to monitor the localized surface plasmon resonance (LSPR) of the AuNPs. The LSPR is sensitive to changes in the dielectric environment at the nanoparticle surface.

Key Observation:

- Red-shift of the LSPR peak: Upon the replacement of the original capping agent (e.g., citrate) with 4-MBA, a red-shift in the LSPR peak is typically observed.[2] This shift indicates a change in the refractive index at the nanoparticle surface, consistent with the formation of a 4-MBA monolayer.

Transmission Electron Microscopy (TEM)

TEM is a crucial technique for characterizing the morphology, size, and dispersion of the AuNPs before and after functionalization with 4-MBA.

Key Observations:

- Size and Shape: TEM images confirm the primary size and shape of the individual AuNPs.
- Dispersion: The dispersion state of the nanoparticles can be assessed. Successful functionalization with 4-MBA should result in well-dispersed nanoparticles, while incomplete or improper functionalization can lead to aggregation.

Experimental Protocols

Synthesis of Citrate-Capped Gold Nanoparticles (AuNPs)

This protocol describes the synthesis of ~15 nm AuNPs using the Turkevich method.

- Preparation: Add 100 mL of 0.01% HAuCl₄ solution to a clean 250 mL flask with a stir bar.
- Heating: Heat the solution to a rolling boil while stirring.
- Reduction: To the boiling solution, rapidly add 4 mL of 1% sodium citrate solution.

- **Color Change:** The solution will change color from pale yellow to gray, then to purple, and finally to a deep red, indicating the formation of AuNPs.
- **Cooling:** Continue boiling for 10-15 minutes, then remove from heat and allow to cool to room temperature with continuous stirring.
- **Storage:** Store the AuNP solution at 4°C.

Functionalization of AuNPs with 4-Mercaptobenzamide (4-MBA)

- **Preparation of 4-MBA solution:** Prepare a 1 mM solution of 4-MBA in ethanol.
- **Addition to AuNPs:** To 10 mL of the prepared AuNP solution, add 100 μ L of the 1 mM 4-MBA solution while stirring.
- **Incubation:** Allow the mixture to react for at least 2 hours at room temperature to ensure complete ligand exchange. Some protocols suggest overnight incubation for the formation of a well-ordered monolayer.
- **Purification:** Centrifuge the solution to pellet the functionalized AuNPs. Remove the supernatant and resuspend the pellet in a fresh solvent (e.g., ethanol or water) to remove excess 4-MBA and the displaced citrate ions. Repeat this washing step at least twice.
- **Final Suspension:** Resuspend the final pellet in the desired solvent for characterization.

SERS Measurement Protocol

- **Sample Preparation:** Deposit a small drop of the 4-MBA functionalized AuNP solution onto a clean SERS substrate (e.g., a silicon wafer or a glass slide) and allow it to dry.
- **Instrumentation:** Use a Raman spectrometer equipped with a laser excitation source (e.g., 633 nm or 785 nm).
- **Data Acquisition:** Acquire the Raman spectrum of the dried sample. Set the acquisition parameters (laser power, integration time, and number of accumulations) to obtain a good signal-to-noise ratio while avoiding sample damage.

- **Data Analysis:** Process the spectrum to identify the characteristic peaks of 4-MBA and confirm the absence of the S-H peak.

XPS Analysis Protocol

- **Sample Preparation:** Deposit a concentrated solution of the 4-MBA functionalized AuNPs onto a clean, conductive substrate (e.g., silicon wafer with a native oxide layer) and allow it to dry completely in a vacuum desiccator.
- **Instrumentation:** Use an XPS instrument with a monochromatic X-ray source (e.g., Al K α).
- **Data Acquisition:** Acquire a survey spectrum to identify all the elements present on the surface. Then, acquire high-resolution spectra for the Au 4f, C 1s, O 1s, N 1s, and S 2p regions.
- **Data Analysis:** Analyze the high-resolution spectra to determine the chemical states and relative atomic concentrations of the elements. Confirm the presence of the S 2p peak and analyze the Au 4f peak shape and position.

UV-Vis Spectroscopy Protocol

- **Instrumentation:** Use a dual-beam UV-Vis spectrophotometer.
- **Blank Measurement:** Use the solvent in which the AuNPs are suspended as the blank.
- **Sample Measurement:** Place the cuvette containing the AuNP solution (both before and after functionalization with 4-MBA) in the sample holder and record the absorbance spectrum over a wavelength range of at least 400-800 nm.
- **Data Analysis:** Determine the wavelength of the LSPR peak maximum for both the unfunctionalized and functionalized AuNPs and calculate the peak shift.

TEM Sample Preparation and Analysis Protocol

- **Grid Preparation:** Place a drop of the AuNP solution (before and after functionalization) onto a carbon-coated TEM grid.

- Drying: Allow the solvent to evaporate completely. Wick away excess liquid with filter paper to prevent the formation of large aggregates.
- Imaging: Insert the grid into the TEM and acquire images at various magnifications to assess the size, shape, and dispersion of the nanoparticles.

Visualizing the Workflow

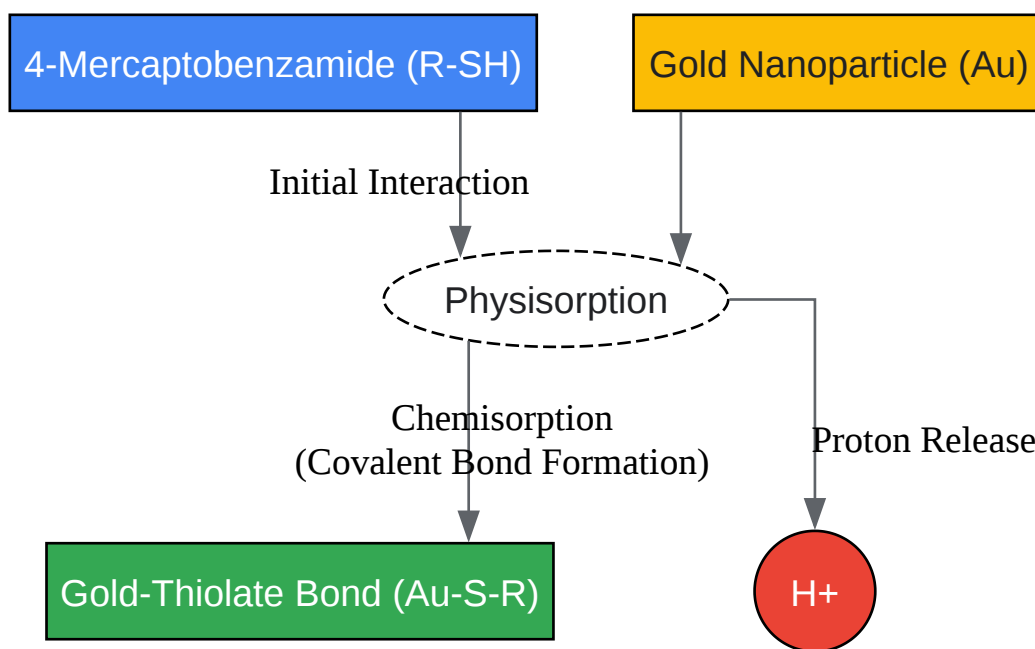
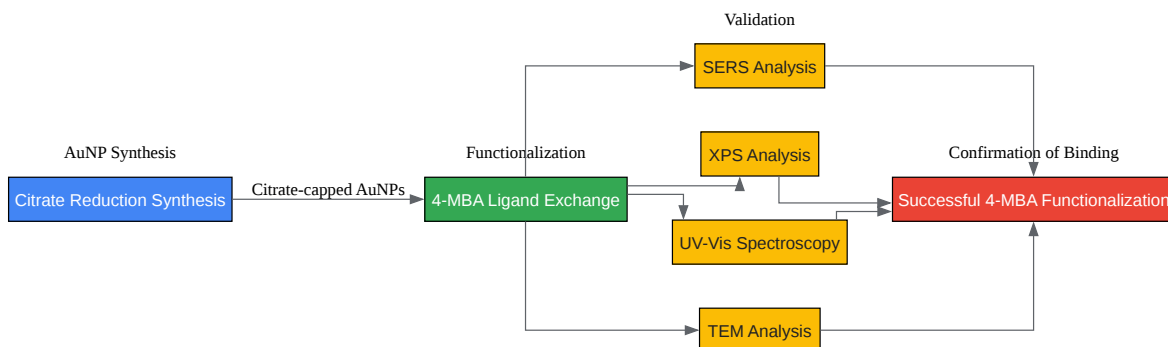

[Click to download full resolution via product page](#)

Need Custom Synthesis?

BenchChem offers custom synthesis for rare earth carbides and specific isotopic labeling.

Email: info@benchchem.com or [Request Quote Online](#).

References

- 1. Reusable SERS Substrates Based on Gold Nanoparticles for Peptide Detection - PMC [pmc.ncbi.nlm.nih.gov]
- 2. mdpi.com [mdpi.com]
- To cite this document: BenchChem. [Validating the Binding of 4-Mercaptobenzamide to Gold Nanoparticles: A Comparative Guide]. BenchChem, [2025]. [Online PDF]. Available at: [https://www.benchchem.com/product/b3273640#validating-the-binding-of-4-mercaptobenzamide-to-gold-nanoparticles]

Disclaimer & Data Validity:

The information provided in this document is for Research Use Only (RUO) and is strictly not intended for diagnostic or therapeutic procedures. While BenchChem strives to provide accurate protocols, we make no warranties, express or implied, regarding the fitness of this product for every specific experimental setup.

Technical Support: The protocols provided are for reference purposes. Unsure if this reagent suits your experiment? [[Contact our Ph.D. Support Team for a compatibility check](#)]

Need Industrial/Bulk Grade? [Request Custom Synthesis Quote](#)

BenchChem

Our mission is to be the trusted global source of essential and advanced chemicals, empowering scientists and researchers to drive progress in science and industry.

Contact

Address: 3281 E Guasti Rd
Ontario, CA 91761, United States
Phone: (601) 213-4426
Email: info@benchchem.com

