

Technical Guide: Biological Activity & Therapeutic Potential of Fluorinated Pyrazine Derivatives

Author: BenchChem Technical Support Team. **Date:** April 2026

Compound of Interest

Compound Name:	<i>5-Bromo-3,6-difluoro-N,N-dimethylpyrazin-2-amine</i>
CAS No.:	55215-65-1
Cat. No.:	B3271668

[Get Quote](#)

Executive Summary

The pyrazine scaffold (1,4-diazine) is a privileged structure in medicinal chemistry, distinguished by its ability to act as a bioisostere of benzene, pyridine, and pyrimidine. However, the introduction of fluorine atoms onto the pyrazine ring elevates this scaffold from a simple structural spacer to a functional pharmacophore. This guide analyzes the "Fluorine Effect" on pyrazine derivatives, detailing how strategic fluorination modulates pKa, metabolic stability, and binding affinity. We examine two primary therapeutic verticals: RdRp-targeting antivirals (exemplified by Favipiravir) and ATP-competitive kinase inhibitors for oncology.

Chemical Rationale: The Fluorine Effect

The biological efficacy of fluorinated pyrazines is not accidental; it is driven by specific physicochemical alterations induced by the C-F bond.

Electronic Modulation and pKa

The pyrazine nitrogen atoms are weakly basic ($pK_a \sim 0.6$). Fluorine, being the most electronegative element, exerts a strong inductive effect (

-).
- **Basicity Reduction:** Fluorine substitution adjacent to pyrazine nitrogens further lowers the pK_a , reducing protonation at physiological pH. This increases the fraction of the neutral species, enhancing membrane permeability (LogD).
 - **Dipole Moments:** The C-F bond introduces a strong dipole that can engage in orthogonal dipolar interactions within protein binding pockets, distinct from hydrogen bonding.

Metabolic Blocking

Pyrazines are susceptible to oxidative metabolism (hydroxylation) by cytochrome P450 enzymes, typically at the C-2 or C-3 positions.

- **C-F Bond Strength:** The C-F bond (approx. 116 kcal/mol) is significantly stronger than the C-H bond. Substituting metabolic "soft spots" with fluorine blocks oxidative degradation, extending the half-life () of the drug.

Therapeutic Vertical I: Antivirals (RdRp Inhibitors)

The most prominent application of fluorinated pyrazines is in targeting RNA-dependent RNA polymerase (RdRp) of RNA viruses (Influenza, Ebola, SARS-CoV-2).

Case Study: Favipiravir (T-705)

Compound: 6-fluoro-3-hydroxy-2-pyrazinecarboxamide Mechanism of Action: Favipiravir is a prodrug.^[1] It is phosphoribosylated intracellularly by HGPRT (hypoxanthine-guanine phosphoribosyltransferase) to form Favipiravir-ribofuranosyl-5'-triphosphate (T-705-RTP).^[1]

- **Mimicry:** T-705-RTP mimics a purine nucleotide (Guanosine/Adenosine).
- **Inhibition:** It is recognized by the viral RdRp and incorporated into the nascent RNA strand.^[1]

- Termination: Incorporation induces lethal mutagenesis or non-obligate chain termination, halting viral replication.[1]

Experimental Protocol: Synthesis of Favipiravir

Rationale: While early routes used 3-hydroxypyrazine-2-carboxylic acid (4 steps), the fluorine-displacement route via 3,6-dichloropyrazine-2-carbonitrile is more efficient for generating the fluorinated core.

Reagents: 3,6-dichloropyrazine-2-carbonitrile, Potassium Fluoride (KF), Tetrabutylammonium bromide (TBAB), DMSO, NaOH, H₂O₂.

Step-by-Step Methodology:

- Fluorination (Halex Reaction):
 - Charge a reaction vessel with 3,6-dichloropyrazine-2-carbonitrile (1.0 eq) and spray-dried KF (2.5 eq).
 - Add dry DMSO (5 volumes) and TBAB (0.1 eq) as a phase transfer catalyst.
 - Heat to 120°C for 4–6 hours under atmosphere.
 - Checkpoint: Monitor by HPLC for conversion to 3,6-difluoropyrazine-2-carbonitrile.
 - Workup: Cool, dilute with water, and extract with ethyl acetate. Concentrate to obtain the difluoro intermediate.
- Regioselective Hydrolysis:
 - Dissolve the intermediate in 1,4-dioxane.
 - Add concentrated HCl (1.0 eq) and heat to 50°C.
 - Mechanism:[2][3] The C-2 nitrile is hydrolyzed to the amide, and the C-3 fluorine is selectively displaced by water (favored by the para activating effect of the nitrile/amide).

- Isolate 6-fluoro-3-hydroxy-2-pyrazinecarbonitrile (Note: Partial hydrolysis may occur; controlled conditions yield the amide).
- Final Hydroxylation/Amidation:
 - Treat the nitrile intermediate with NaOH/H₂O₂ at 0°C to convert the nitrile to the primary amide.
 - Acidify to pH 3 to precipitate Favipiravir. Recrystallize from ethanol/water.

Experimental Protocol: In Vitro RdRp Inhibition Assay

Objective: Quantify the IC₅₀ of a fluorinated pyrazine against Influenza A RdRp.

- Cell System: HEK-293T cells.
- Plasmids: Transfect cells with plasmids expressing Influenza A Polymerase subunits (PB1, PB2, PA) and Nucleoprotein (NP), plus a vRNA-like reporter (Luciferase gene flanked by viral UTRs).
- Compound Treatment:
 - Seed transfected cells in 96-well plates (20,000 cells/well).^[4]
 - Add test compound (Fluorinated Pyrazine) in serial dilutions (0.1 μM to 100 μM).
 - Include Favipiravir as a positive control and DMSO as a vehicle control.
- Incubation: Incubate at 37°C for 24 hours.
- Readout:
 - Lyse cells and add Luciferase substrate.
 - Measure luminescence. High luminescence = active RdRp. Low luminescence = Inhibition.
 - Calculate IC₅₀ using non-linear regression (GraphPad Prism).

Therapeutic Vertical II: Anticancer (Kinase Inhibitors)

Fluorinated pyrazines serve as excellent hinge-binders in ATP-competitive kinase inhibitors (e.g., FGFR, c-Met, VEGFR).

Structural Logic

The pyrazine nitrogen acts as a Hydrogen Bond Acceptor (HBA) to the backbone NH of the kinase hinge region. Fluorine substitution on the ring or pendant groups modulates the electron density of this nitrogen, tuning the H-bond strength.

Pathway Visualization

The following diagram illustrates the signaling cascade targeted by Pyrazine-based FGFR inhibitors.

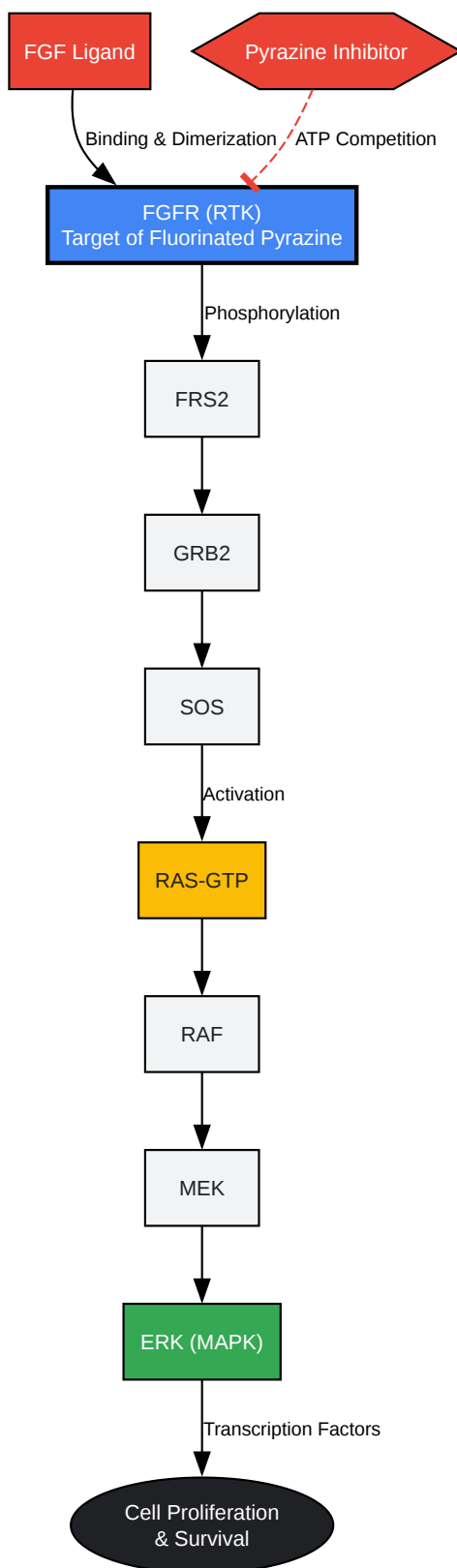

[Click to download full resolution via product page](#)

Caption: FGFR signaling cascade. Fluorinated pyrazines competitively bind the ATP pocket of FGFR, blocking autophosphorylation and downstream RAS/MAPK signaling.

Comparative SAR Data

The table below highlights how fluorine substitution improves potency compared to non-fluorinated analogs in c-Met/FGFR inhibitors.

Compound ID	Structure Core	Substitution (R)	Target	IC50 (nM)	Effect of Fluorine
PYZ-H (Ctrl)	Pyrazolo[2,3-b]pyrazine	Hydrogen	c-Met	120	Baseline activity.
PYZ-F1	Pyrazolo[2,3-b]pyrazine	6-Fluoro	c-Met	28	4-fold potency increase due to metabolic stability and electronic tuning.
FGFR-H	Pyrazine-2-carboxamide	Phenyl	FGFR1	450	Moderate binding.
FGFR-F2	Pyrazine-2-carboxamide	3,5-Difluorophenyl	FGFR1	65	Enhanced lipophilicity (LogP) and dipole interaction in the hydrophobic pocket.

References

- Mechanism of Action of T-705 (Favipiravir): Furuta, Y., et al. "Mechanism of action of T-705 ribosyl triphosphate against influenza virus RNA polymerase." *Antimicrobial Agents and Chemotherapy*, 2005. [Link](#)

- Synthesis of Fluorinated Pyrazines: Jin, Z., et al. "Synthesis and crystal structure of 6-fluoro-3-hydroxypyrazine-2-carboxamide." Chemical Research in Chinese Universities, 2014. [Link](#)
- RdRp Assay Protocols: Zhang, S., et al. "A Parallel Phenotypic Versus Target-Based Screening Strategy for RNA-Dependent RNA Polymerase Inhibitors of the Influenza A Virus." Viruses, 2019.[4] [Link](#)
- Pyrazine Kinase Inhibitors SAR: Furet, P., et al. "Discovery of NVP-AEW541, a potent and selective inhibitor of the IGF-1R kinase." Bioorganic & Medicinal Chemistry Letters, 2004. [Link](#)
- Fluorine in Medicinal Chemistry: Purser, S., et al. "Fluorine in medicinal chemistry." Chemical Society Reviews, 2008. [Link](#)

Need Custom Synthesis?

BenchChem offers custom synthesis for rare earth carbides and specific isotopic labeling.

Email: info@benchchem.com or [Request Quote Online](#).

Sources

- 1. pdf.benchchem.com [pdf.benchchem.com]
- 2. mdpi.com [mdpi.com]
- 3. sciforum.net [sciforum.net]
- 4. A Parallel Phenotypic Versus Target-Based Screening Strategy for RNA-Dependent RNA Polymerase Inhibitors of the Influenza A Virus - PMC [[pmc.ncbi.nlm.nih.gov](https://pubmed.ncbi.nlm.nih.gov/)]
- To cite this document: BenchChem. [Technical Guide: Biological Activity & Therapeutic Potential of Fluorinated Pyrazine Derivatives]. BenchChem, [2026]. [Online PDF]. Available at: [<https://www.benchchem.com/product/b3271668/docs#technical-guide-biological-activity-therapeutic-potential-of-fluorinated-pyrazine-derivatives>]

Disclaimer & Data Validity:

The information provided in this document is for Research Use Only (RUO) and is strictly not intended for diagnostic or therapeutic procedures. While BenchChem strives to provide

accurate protocols, we make no warranties, express or implied, regarding the fitness of this product for every specific experimental setup.

Technical Support: The protocols provided are for reference purposes. Unsure if this reagent suits your experiment?

Need Industrial/Bulk Grade? [Request Custom Synthesis Quote](#)

BenchChem

Our mission is to be the trusted global source of essential and advanced chemicals, empowering scientists and researchers to drive progress in science and industry.

Contact

Address: 3281 E Guasti Rd

Ontario, CA 91761, United States

Phone: (601) 213-4426

Email: info@benchchem.com

[Contact our Ph.D. Support Team for a compatibility check](#)