

Application Note: Chemoselective Functionalization of Ethyl 2-(2-bromo-4-chlorophenyl)acetate

Author: BenchChem Technical Support Team. **Date:** April 2026

Compound of Interest

Compound Name:	Ethyl 2-(2-bromo-4-chlorophenyl)acetate
CAS No.:	52864-55-8
Cat. No.:	B3270511

[Get Quote](#)

Executive Summary

This application note details the chemoselective functionalization of **Ethyl 2-(2-bromo-4-chlorophenyl)acetate**, a high-value bifunctional scaffold for medicinal chemistry. This molecule features three distinct reactive sites: an ortho-bromide (high reactivity), a para-chloride (latent reactivity), and an

-methylene ester (nucleophilic/electrophilic handle).

By exploiting the significant rate difference in oxidative addition between aryl bromides and aryl chlorides (

), researchers can selectively functionalize the C2-position while preserving the C4-chloride for subsequent derivatization. Furthermore, this guide outlines a validated workflow for converting this linear ester into substituted oxindoles (indolin-2-ones) via a tandem Buchwald-Hartwig amination/intramolecular cyclization sequence—a critical transformation in the synthesis of kinase inhibitors and GPCR modulators.

Substrate Analysis & Chemoselectivity Strategy

To design effective protocols, one must understand the electronic and steric environment of the substrate.

Reactive Sites Map

- Site A (C2-Br): The primary site for Pd(0) insertion. Located ortho to the acetate side chain. Steric hindrance is moderate but does not prevent coupling with standard ligands.
- Site B (C4-Cl): The secondary site. The C-Cl bond is stronger (BDE ~95 kcal/mol) than C-Br (~80 kcal/mol). Under standard Suzuki conditions (C, carbonate base), this site remains inert.
- Site C (-Methylene): The protons at C are acidic (in DMSO). Strong bases (e.g., NaOBu, LiHMDS) can generate the enolate, leading to potential side reactions (e.g., self-condensation or competing arylation). Mitigation: Use weak bases (e.g., Na₂CO₃) for cross-coupling.

Mechanistic Logic: The Kinetic Window

The success of chemoselective coupling relies on the "Kinetic Window."

Using electron-rich, bulky phosphines (e.g., P(t-Bu)₃,

Bu)

, XPhos) can narrow this window by activating the chloride. Therefore, for pure selectivity, Triphenylphosphine (PPh₃)

) or dppf are preferred over "super-ligands" in the first step.

Visualization: Chemoselectivity & Pathways

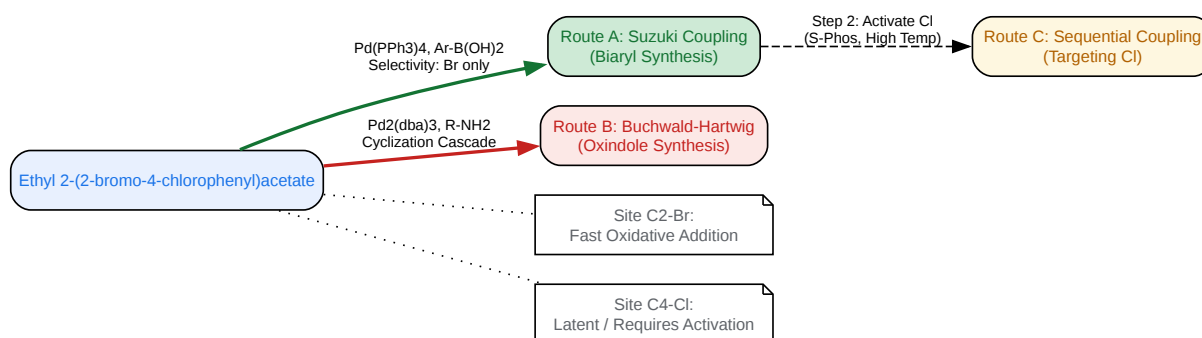

[Click to download full resolution via product page](#)

Caption: Strategic map showing divergent pathways based on chemoselective activation of the C2-Bromide.

Detailed Experimental Protocols

Protocol A: Chemoselective Suzuki-Miyaura Coupling

Objective: Synthesize Ethyl 2-(4-chloro-[1,1'-biphenyl]-2-yl)acetate derivatives without touching the chlorine or hydrolyzing the ester.

Reagents:

- Substrate (1.0 equiv)
- Arylboronic acid (1.2 equiv)
- Catalyst: Pd(PPh

)

(3-5 mol%) — Chosen for high Br/Cl selectivity.

- Base: K

CO

(2.5 equiv) — Mild enough to prevent ester hydrolysis.

- Solvent: Toluene/Ethanol/Water (4:1:1) or DME/Water (5:1).
- Temperature: 80 °C.

Step-by-Step Procedure:

- Setup: Charge a reaction vial with the substrate (1.0 mmol), arylboronic acid (1.2 mmol), and K

CO

(2.5 mmol).

- Inerting: Evacuate and backfill with Nitrogen () three times.

- Solvent Addition: Add degassed Toluene (4 mL), Ethanol (1 mL), and Water (1 mL).

- Catalyst Addition: Add Pd(PPh

)

(58 mg, 0.05 mmol) under a positive stream of

.

- Reaction: Seal the vessel and heat to 80 °C for 4–6 hours. Monitor by TLC/LCMS. Do not exceed 100 °C to avoid Cl activation.

- Workup: Cool to RT. Dilute with Ethyl Acetate (EtOAc) and wash with water.^[1] Dry organic layer over MgSO₄ and wash with water.^[1] Dry organic layer over MgSO₄ and wash with water.^[1]

.

- Purification: Silica gel chromatography (Hexanes/EtOAc gradient).

Checkpoint: The product should retain the Chlorine signal (typical 3:1 isotope pattern in MS) and the Ethyl ester signals (

H NMR: q ~4.1 ppm, t ~1.2 ppm).

Protocol B: Oxindole Synthesis (Buchwald-Hartwig Cascade)

Objective: One-pot synthesis of N-substituted 6-chlorooxindoles. This reaction couples the amine to the C2-Br and then spontaneously cyclizes onto the ester.

Mechanism:

- Amination: Pd-catalyzed C-N bond formation at C2.
- Lactamization: Intramolecular nucleophilic acyl substitution (5-exo-trig).

Reagents:

- Substrate (1.0 equiv)
- Primary Amine R-NH
(1.2 equiv) — Alkyl or Aryl amines.
- Catalyst: Pd
(dba)
(2.5 mol%)
- Ligand: Xantphos (5 mol%) — Large bite angle promotes reductive elimination and stability.
- Base: Cs
CO
(2.0 equiv) — Promotes amination and subsequent cyclization.

- Solvent: 1,4-Dioxane (anhydrous).
- Temperature: 100 °C.

Step-by-Step Procedure:

- Glovebox/Schlenk: In an inert atmosphere, combine Pd (dba) (23 mg, 0.025 mmol) and Xantphos (29 mg, 0.05 mmol) in Dioxane (2 mL). Stir for 5 mins to form the active catalyst (solution turns from purple to orange/yellow).
- Substrate Addition: Add the substrate (1.0 mmol), Cs CO (650 mg, 2.0 mmol), and the primary amine (1.2 mmol). Add remaining Dioxane (3 mL).
- Heating: Heat to 100 °C for 12–16 hours.
- Monitoring: LCMS will show the intermediate amino-ester (M+H) and the cyclized oxindole (M-EtOH). If cyclization is incomplete, add a catalytic amount of acetic acid (AcOH) during workup or heat the crude residue in ethanol/reflux.
- Isolation: Filter through Celite. Concentrate. Purify via flash chromatography.

Visual Workflow: Oxindole Cascade

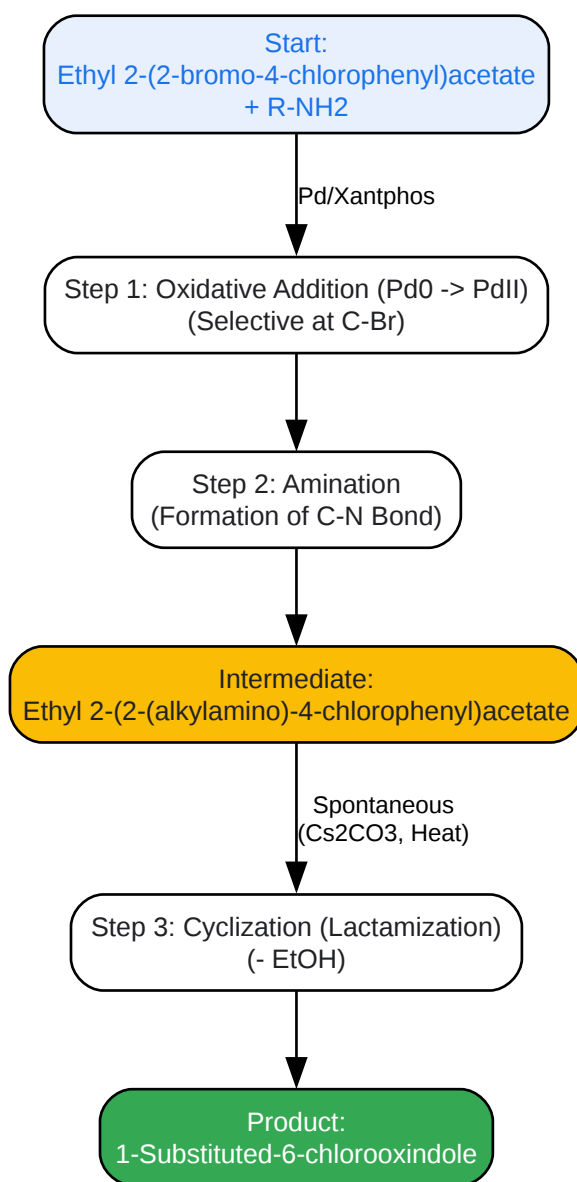

[Click to download full resolution via product page](#)

Caption: Cascade synthesis of 6-chlorooxindoles from the bromo-ester scaffold.

Troubleshooting & Optimization Table

Issue	Probable Cause	Solution
Low Conversion (Suzuki)	Catalyst deactivation or impure reagents.	Switch to Pd(dppf)Cl . Ensure solvent is degassed thoroughly.
Loss of Chemoselectivity	Temperature too high or ligand too active.	Lower temp to 60°C. Use Pd(PPh)) instead of S-Phos/XPhos.
-Arylation Side Product	Base is too strong (enolization).	Use K PO or K CO . Avoid NaO Bu.
Incomplete Cyclization (Oxindole)	Steric bulk of amine or insufficient heat.	Treat crude intermediate with pTSA (cat.) in refluxing Ethanol.
Dehalogenation (Loss of Br/Cl)	-Hydride elimination from Pd-H species.	Avoid alcohol solvents in the Pd step if possible (use Toluene/Dioxane).

References

- Chemoselectivity Principles: Littke, A. F., & Fu, G. C. (2002). Palladium-catalyzed cross-coupling reactions of aryl chlorides. *Angewandte Chemie International Edition*, 41(22), 4176-4211. [Link](#)
- Oxindole Synthesis: Lee, S., & Hartwig, J. F. (2001).^[2] Palladium-catalyzed synthesis of oxindoles from

-chloroacetanilides.[2][3] The Journal of Organic Chemistry, 66(10), 3402-3415. [Link](#)

- Buchwald-Hartwig Cyclization: Hennessy, E. J., & Buchwald, S. L. (2003). A general and mild copper-catalyzed arylation of diethyl malonates. Journal of the American Chemical Society, 125(39), 12084-12085. [Link](#)
- Suzuki Coupling of Halo-Esters: Miyaura, N., & Suzuki, A. (1995). Palladium-catalyzed cross-coupling reactions of organoboron compounds. Chemical Reviews, 95(7), 2457-2483. [Link](#)

Disclaimer: This protocol is intended for research use only. Always consult Safety Data Sheets (SDS) before handling halogenated aromatics and palladium catalysts.

Need Custom Synthesis?

BenchChem offers custom synthesis for rare earth carbides and specific isotopic labeling.

Email: info@benchchem.com or [Request Quote Online](#).

Sources

- [1. mdpi.com](https://www.mdpi.com) [[mdpi.com](https://www.mdpi.com)]
- [2. organic-chemistry.org](https://www.organic-chemistry.org) [[organic-chemistry.org](https://www.organic-chemistry.org)]
- [3. Synthesis of Substituted Oxindoles from \$\alpha\$ -Chloroacetanilides via Palladium-Catalyzed C-H Functionalization](https://www.organic-chemistry.org) [[organic-chemistry.org](https://www.organic-chemistry.org)]
- To cite this document: BenchChem. [Application Note: Chemoselective Functionalization of Ethyl 2-(2-bromo-4-chlorophenyl)acetate]. BenchChem, [2026]. [Online PDF]. Available at: [<https://www.benchchem.com/product/b3270511/docs#application-note-chemoselective-functionalization-of-ethyl-2-2-bromo-4-chlorophenyl-acetate>]

Disclaimer & Data Validity:

The information provided in this document is for Research Use Only (RUO) and is strictly not intended for diagnostic or therapeutic procedures. While BenchChem strives to provide accurate protocols, we make no warranties, express or implied, regarding the fitness of this product for every specific experimental setup.

Technical Support: The protocols provided are for reference purposes. Unsure if this reagent suits your experiment?

Need Industrial/Bulk Grade? [Request Custom Synthesis Quote](#)

BenchChem

Our mission is to be the trusted global source of essential and advanced chemicals, empowering scientists and researchers to drive progress in science and industry.

Contact

Address: 3281 E Guasti Rd

Ontario, CA 91761, United States

Phone: (601) 213-4426

Email: info@benchchem.com

[Contact our Ph.D. Support Team for a compatibility check](#)