

Technical Procurement & Application Guide: 4-Bromo-3,3'-bipyridine

Author: BenchChem Technical Support Team. **Date:** April 2026

Compound of Interest

Compound Name: 4-Bromo-3-(pyridin-3-yl)pyridine

CAS No.: 440112-19-6

Cat. No.: B3266994

[Get Quote](#)

CAS: 440112-19-6 | Formula: $C_{10}H_7BrN_2$ | MW: 235.08 g/mol [1][2]

Executive Summary

4-Bromo-3,3'-bipyridine is a high-value heteroaromatic scaffold utilized primarily in the synthesis of Type II kinase inhibitors and organic light-emitting diode (OLED) host materials.[2] Its structural uniqueness lies in the orthogonal reactivity of its halogen handle (C4-Br) relative to the bipyridine core.[2] Unlike symmetrical bipyridines, this intermediate allows for divergent synthesis—enabling the sequential introduction of nucleophiles (via

or Pd-catalysis) while retaining the bipyridine chelation or electronic properties.[2]

This guide provides a self-validating framework for sourcing this material, verifying its purity against critical regioisomeric impurities, and deploying it in high-yield cross-coupling protocols.

Chemical Specifications & Critical Quality Attributes (CQAs)

When procuring 4-bromo-3,3'-bipyridine, standard purity (>95%) is insufficient for late-stage pharmaceutical intermediates due to the prevalence of difficult-to-separate regioisomers.[2]

Technical Data Table

Property	Specification	Rationale
Appearance	Off-white to pale yellow solid	Darkening indicates oxidation or trace Ru/Pd contaminants. [2]
Purity (HPLC)	97.0% (Area %)	Critical to prevent side-reactions in downstream couplings.[2]
Regioisomeric Impurity	1.0% (4-(pyridin-3-yl)-3-bromopyridine)	The para-coupling isomer is a common byproduct of non-selective synthesis.[2]
Halogen Content	Br: 33-35% (Theoretical: 34.0%)	Verifies mono-bromination vs. dibromo species.[2]
Pd Content	50 ppm	Essential if used in GMP steps to meet ICH Q3D guidelines.
Water (KF)	0.5%	Pyridines are hygroscopic; water quenches sensitive organometallics.[2]

The Impurity Challenge

The synthesis of this scaffold typically involves a Suzuki cross-coupling between a 3,4-dihalopyridine and 3-pyridylboronic acid.[2] If the starting material is 3,4-dibromopyridine, the catalyst may oxidatively add to either the C3 or C4 position.[2]

- Target: C3-coupling (leaving C4-Br intact).
- Impurity: C4-coupling (leaving C3-Br intact).
- Detection: These isomers have very similar

values but distinct ^1H NMR shifts. The proton adjacent to the bromine in the target (C2-H) appears as a sharp singlet further downfield due to the adjacent ring current and inductive effects.[2]

Synthetic Utility & Divergent Pathways

The C4-bromo position is activated by the electron-deficient pyridine ring, making it highly susceptible to Palladium-catalyzed cross-couplings and Nucleophilic Aromatic Substitution (

).[2]

Divergent Synthesis Workflow

The following diagram illustrates how this single building block serves as a linchpin for diverse chemical libraries.

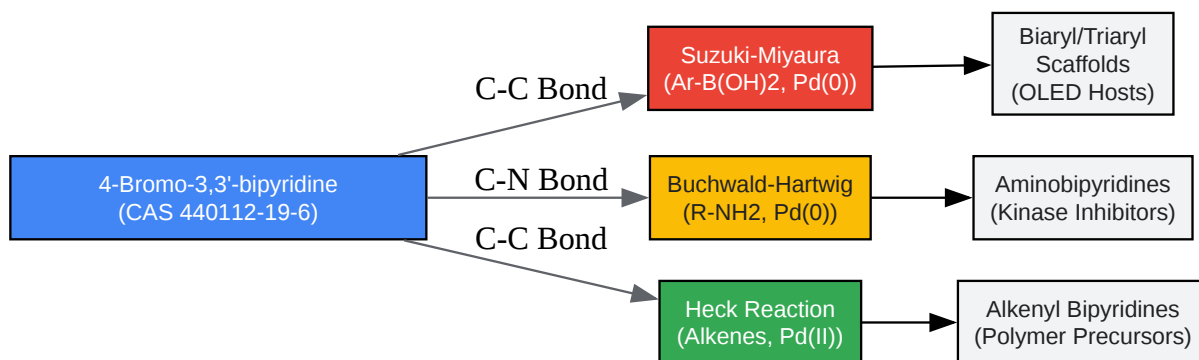

[Click to download full resolution via product page](#)

Figure 1: Divergent functionalization pathways for 4-bromo-3,3'-bipyridine.[2]

Experimental Protocol: Suzuki-Miyaura Coupling

This protocol demonstrates the self-validating utility of the purchased material.[2] It couples 4-bromo-3,3'-bipyridine with phenylboronic acid to yield 3,3'-bipyridin-4-ylbenzene.[2]

Reagents & Stoichiometry

- Substrate: 4-Bromo-3,3'-bipyridine (1.0 equiv, 235 mg, 1.0 mmol)

- Coupling Partner: Phenylboronic acid (1.2 equiv, 146 mg)[2]
- Catalyst:
(3 mol%)[2]
- Base:
(3.0 equiv, 2M aqueous solution)[2]
- Solvent: 1,4-Dioxane (degassed)[2]

Step-by-Step Methodology

- Inert Setup: Charge a dried Schlenk tube with the substrate, boronic acid, and catalyst. Evacuate and backfill with Argon ().[2]
 - Why:
species generated in situ are oxygen-sensitive.[2] Oxygen promotes homocoupling of the boronic acid.
- Solvation: Add degassed 1,4-dioxane (5 mL) and 2M (1.5 mL).
 - Why: The biphasic system (organic/aqueous) is crucial for the transmetallation step involving the boronate species.[2]
- Reaction: Heat the mixture to 90°C for 12 hours.
 - Monitoring: Check by TLC (Eluent: 5% MeOH in DCM).[2] The starting bromide () should disappear; product appears at (highly fluorescent under UV 254nm).[2]
- Workup: Cool to RT. Dilute with EtOAc, wash with brine, dry over

- Purification: Flash column chromatography (Gradient: 0

5% MeOH/DCM).

Validation Check

- ^1H NMR (400 MHz, CDCl_3): Look for the disappearance of the C2-H singlet of the starting material (8.8 ppm) and the appearance of new aromatic protons corresponding to the phenyl ring.^[2]
- Mass Spec: Expected

Quality Control & Sourcing Strategy

When evaluating suppliers, request a batch-specific Certificate of Analysis (CoA) including the full NMR spectrum.^[2]

QC Decision Tree

Use this workflow to accept or reject incoming batches.

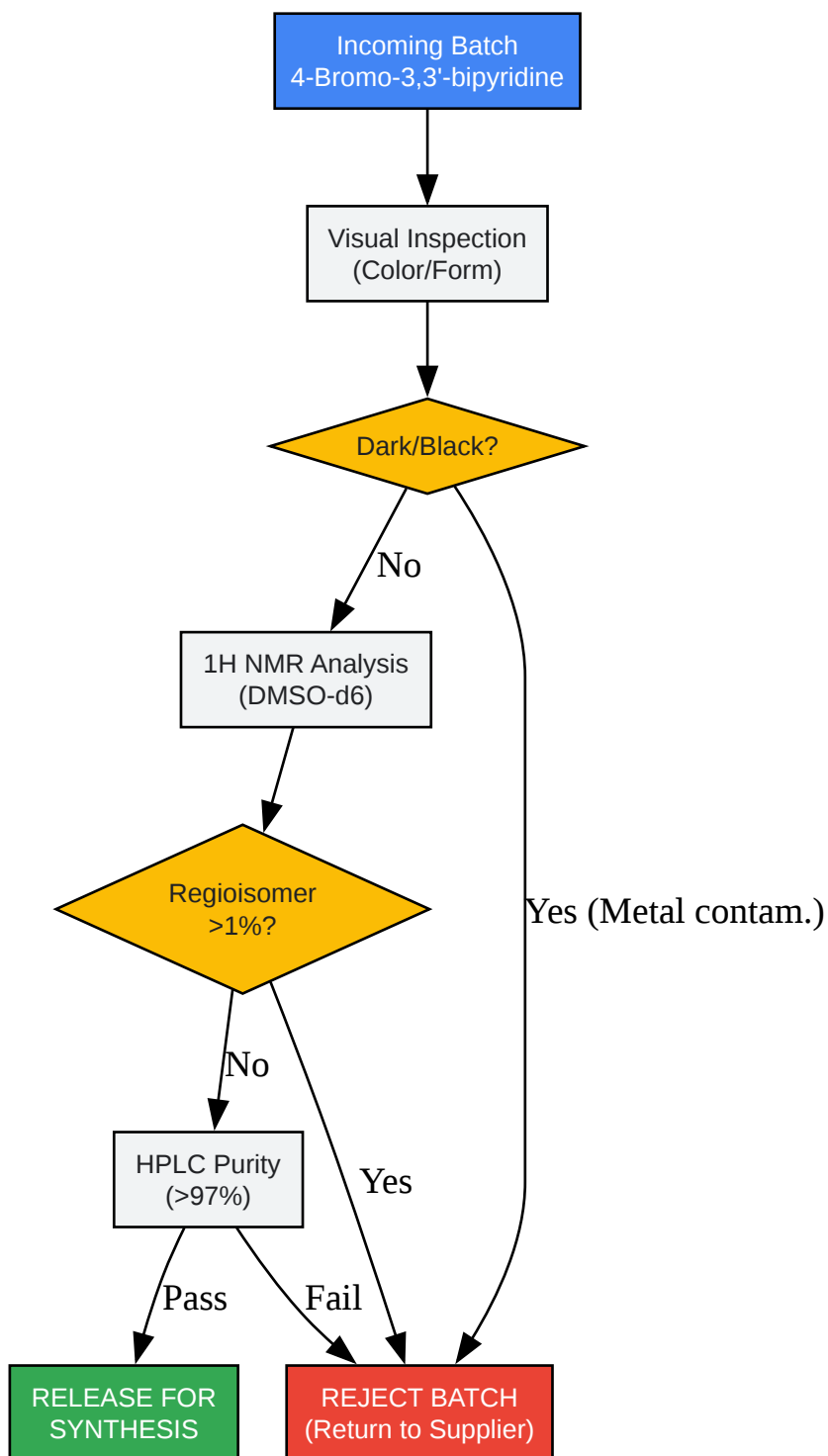

[Click to download full resolution via product page](#)

Figure 2: Quality Control decision matrix for incoming raw material.

Storage & Handling

- Storage: Store at 2-8°C under Argon.
- Stability: Stable in solid form for >1 year. Solutions in chlorinated solvents (DCM/Chloroform) should be used immediately as pyridines can react with DCM over time to form pyridinium salts (quaternization).[2]
- Safety: Irritant. Wear gloves and goggles. Avoid dust inhalation.

References

- Sigma-Aldrich. 4-Bromo-3,3'-bipyridine Product Specification. [Link](#) (Accessed 2024).[2]
- Miyaura, N., & Suzuki, A. (1995).[2] "Palladium-Catalyzed Cross-Coupling Reactions of Organoboron Compounds". Chemical Reviews, 95(7), 2457–2483.[2] [Link](#)[2]
- Denton, S. et al. (2024). "Recent Progress on the Synthesis of Bipyridine Derivatives". Molecules, 29(3), 576.[2][3] [Link](#)
- PubChem.Compound Summary for CAS 440112-19-6. National Library of Medicine. [Link](#)[2]

Need Custom Synthesis?

BenchChem offers custom synthesis for rare earth carbides and specific isotopic labeling.

Email: info@benchchem.com or [Request Quote Online](#).

Sources

- 1. 4 4 bipyridine | Sigma-Aldrich [sigmaaldrich.com]
- 2. arkat-usa.org [arkat-usa.org]
- 3. Recent Progress on the Synthesis of Bipyridine Derivatives [mdpi.com]
- To cite this document: BenchChem. [Technical Procurement & Application Guide: 4-Bromo-3,3'-bipyridine]. BenchChem, [2026]. [Online PDF]. Available at: [<https://www.benchchem.com/product/b3266994/docs#technical-procurement-application-guide-4-bromo-3-3-bipyridine>]

Disclaimer & Data Validity:

The information provided in this document is for Research Use Only (RUO) and is strictly not intended for diagnostic or therapeutic procedures. While BenchChem strives to provide accurate protocols, we make no warranties, express or implied, regarding the fitness of this product for every specific experimental setup.

Technical Support: The protocols provided are for reference purposes. Unsure if this reagent suits your experiment?

Need Industrial/Bulk Grade? [Request Custom Synthesis Quote](#)

BenchChem

Our mission is to be the trusted global source of essential and advanced chemicals, empowering scientists and researchers to drive progress in science and industry.

Contact

Address: 3281 E Guasti Rd
Ontario, CA 91761, United States
Phone: (601) 213-4426
Email: info@benchchem.com

[Contact our Ph.D. Support Team for a compatibility check](#)