

A Comparative Guide to Alternative Syntheses of 3-Functionalized 2-Bromoquinolines

Author: BenchChem Technical Support Team. **Date:** April 2026

Compound of Interest

Compound Name: 2-Bromo-3-(bromomethyl)quinoline
CAS No.: 35740-83-1
Cat. No.: B3262564

[Get Quote](#)

For Researchers, Scientists, and Drug Development Professionals

The 2-bromo-3-functionalized quinoline scaffold is a privileged structural motif in medicinal chemistry and materials science. The bromine atom at the C2 position serves as a versatile handle for further chemical modifications, such as cross-coupling reactions, while the functional group at the C3 position is crucial for modulating biological activity and physicochemical properties. This guide provides a comparative overview of key alternative synthetic strategies for accessing this important class of molecules, moving beyond traditional methods to highlight modern, efficient, and versatile approaches. We will delve into the mechanistic underpinnings, practical considerations, and experimental data for each method to empower researchers in their synthetic endeavors.

Electrophilic Cyclization of N-(2-Alkynyl)anilines: A Direct and Atom-Economical Approach

One of the most direct methods for the synthesis of 3-haloquinolines is the electrophilic cyclization of readily available N-(2-alkynyl)anilines. This strategy relies on a 6-endo-dig

cyclization pathway, promoted by an electrophilic halogen source, to construct the quinoline core and install the C3-halogen in a single step.

Mechanistic Rationale

The reaction is initiated by the activation of the alkyne by an electrophile (e.g., Br⁺ from Br₂ or NBS). The nitrogen atom of the aniline then acts as an internal nucleophile, attacking the activated alkyne in a 6-endo-dig fashion. Subsequent aromatization, often facilitated by a mild base or upon workup, affords the 3-bromoquinoline product. The choice of electrophile and reaction conditions can be tuned to optimize yields and substrate scope.

Experimental Protocol: Synthesis of 3-Bromo-4-phenylquinoline via Electrophilic Cyclization[1]
[2]

- To a solution of N-(phenylethynyl)aniline (1.0 mmol) in acetonitrile (10 mL) at 0 °C, add N-bromosuccinimide (NBS) (1.1 mmol) portionwise.
- Allow the reaction mixture to warm to room temperature and stir for 2-4 hours, monitoring the reaction progress by TLC.
- Upon completion, quench the reaction with a saturated aqueous solution of sodium thiosulfate.
- Extract the mixture with ethyl acetate (3 x 20 mL).
- Combine the organic layers, wash with brine, dry over anhydrous sodium sulfate, and concentrate under reduced pressure.
- Purify the crude product by column chromatography on silica gel (eluent: hexane/ethyl acetate) to afford the desired 3-bromo-4-phenylquinoline.

Performance Comparison

| Method | Key Advantages | Key Limitations | Typical Yields |
|---------------------------|---|---|----------------|
| Electrophilic Cyclization | Direct, one-pot synthesis; Mild reaction conditions; Good functional group tolerance. ^{[1][2]} | Requires synthesis of N-(2-alkynyl)aniline precursors; Potential for side reactions with highly activated anilines. | 60-90% |

Lithiation-Cyclization of 2-(2,2-Dibromoethenyl)phenyl Isocyanides: A Versatile Intermediate Approach

A powerful strategy for introducing a wide range of functional groups at the C3 position involves the generation of a 2-bromo-3-lithioquinoline intermediate. This is elegantly achieved through the reaction of 2-(2,2-dibromoethenyl)phenyl isocyanides with butyllithium.

Mechanistic Rationale

Treatment of the 2-(2,2-dibromoethenyl)phenyl isocyanide with one equivalent of butyllithium at low temperature results in a selective lithium-halogen exchange at the vinylic position, followed by an intramolecular cyclization of the resulting vinyl lithium onto the isocyanide carbon. This process forms the 2-bromo-3-lithioquinoline in situ. This highly reactive intermediate can then be trapped with a variety of electrophiles to install the desired C3-functional group. A similar transformation can be achieved starting from 2-(2,2-dibromoethenyl)phenyl isothiocyanates to yield 3-bromoquinoline-2(1H)-thiones.^{[3][4]}

Experimental Protocol: Synthesis of 3-Formyl-2-bromoquinoline

- To a solution of 2-(2,2-dibromoethenyl)phenyl isocyanide (1.0 mmol) in anhydrous THF (10 mL) at -78 °C under an inert atmosphere, add n-butyllithium (1.1 mmol, 1.6 M in hexanes) dropwise.
- Stir the mixture at -78 °C for 30 minutes to generate the 2-bromo-3-lithioquinoline intermediate.

- Add N,N-dimethylformamide (DMF) (1.5 mmol) dropwise and continue stirring at -78 °C for 1 hour.
- Allow the reaction to warm to room temperature and quench with a saturated aqueous solution of ammonium chloride.
- Extract the mixture with diethyl ether (3 x 20 mL).
- Combine the organic layers, wash with brine, dry over anhydrous magnesium sulfate, and concentrate under reduced pressure.
- Purify the crude product by column chromatography on silica gel to afford 3-formyl-2-bromoquinoline.

Performance Comparison

| Method | Key Advantages | Key Limitations | Typical Yields |
|------------------------|--|---|--|
| Lithiation-Cyclization | Access to a wide variety of C3-functional groups via a common intermediate; High regioselectivity. | Requires cryogenic conditions; Sensitive to moisture and air; Multi-step synthesis of the starting isocyanide. ^[4] | 50-85% (depending on the electrophile) |

Palladium-Catalyzed Annulation Reactions: A Convergent Strategy

Transition metal catalysis, particularly with palladium, offers a convergent and flexible approach to construct the 3-functionalized 2-bromoquinoline core. These methods often involve the coupling of readily available starting materials in a cascade or tandem fashion.

Mechanistic Rationale

A representative example involves the palladium-catalyzed annulation of an N-substituted 2-iodoaniline with a bromoalkyne. The catalytic cycle typically begins with the oxidative addition of the 2-iodoaniline to a Pd(0) species. Subsequent carbopalladation of the bromoalkyne, followed by intramolecular C-H activation or a related cyclization event, and finally reductive

elimination, furnishes the quinoline product. The bromine atom from the bromoalkyne is incorporated at the C2 position, and the substituent from the alkyne is installed at the C3 position.

Experimental Protocol: Palladium-Catalyzed Synthesis of 2-Bromo-3-alkylquinolines[5]

- In a sealed tube, combine 2-iodoaniline (1.0 mmol), the corresponding 1-bromoalkyne (1.2 mmol), Pd(OAc)₂ (5 mol%), and a suitable ligand (e.g., PPh₃, 10 mol%) in a solvent such as DMF (5 mL).
- Add a base, for example, K₂CO₃ (2.0 mmol).
- Degas the mixture and purge with an inert gas (e.g., argon).
- Heat the reaction mixture to 100-120 °C for 12-24 hours.
- Cool the reaction to room temperature, dilute with water, and extract with an organic solvent.
- Wash the combined organic layers with brine, dry over anhydrous sulfate, and concentrate.
- Purify the residue by column chromatography to yield the 2-bromo-3-alkylquinoline.

Performance Comparison

| Method | Key Advantages | Key Limitations | Typical Yields |
|--------------------------------|--|---|----------------|
| Palladium-Catalyzed Annulation | High functional group tolerance; Convergent approach using readily available starting materials.[6] [7] | Catalyst cost and sensitivity; May require optimization of ligands and reaction conditions. | 55-80% |

Direct C-H Functionalization: A Modern and Efficient Approach

Direct C-H functionalization has emerged as a powerful tool in modern organic synthesis, offering an atom- and step-economical way to introduce functional groups onto heterocyclic

scaffolds.[8][9][10][11] For the synthesis of 3-functionalized 2-bromoquinolines, this can be envisioned in two ways: C-H functionalization of a pre-existing 2-bromoquinoline or a tandem C-H activation/cyclization sequence.

Mechanistic Rationale

The direct C3-functionalization of a 2-bromoquinoline can be achieved using a transition metal catalyst (e.g., palladium, rhodium, or copper) and a suitable directing group, if necessary, to control regioselectivity. The catalyst activates a C-H bond at the 3-position, which then reacts with a coupling partner. Alternatively, a C-H activation/annulation strategy can construct the quinoline ring and introduce the C3-substituent simultaneously from simpler precursors.

While specific protocols for the direct C3-functionalization of 2-bromoquinolines are still emerging, the principles of C-H activation are well-established and represent a promising future direction.[12]

Conceptual Workflow for C-H Functionalization

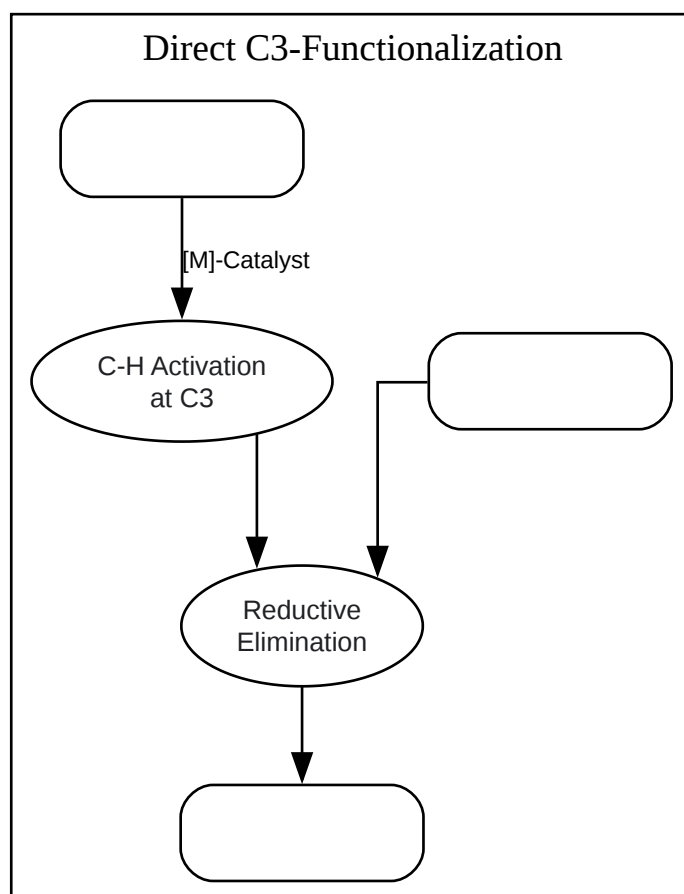

[Click to download full resolution via product page](#)

Caption: Conceptual workflow for direct C3-H functionalization of 2-bromoquinoline.

Performance Comparison

| Method | Key Advantages | Key Limitations | Typical Yields |
|------------------------------|---|--|-----------------|
| Direct C-H Functionalization | High atom economy; Reduced pre-functionalization of starting materials; Potential for late-stage modification. ^{[8][10]} | Regioselectivity can be a challenge; May require directing groups; Field is still developing for this specific scaffold. | Highly variable |

Summary and Outlook

The synthesis of 3-functionalized 2-bromoquinolines can be approached through a variety of strategic pathways, each with its own set of advantages and challenges.

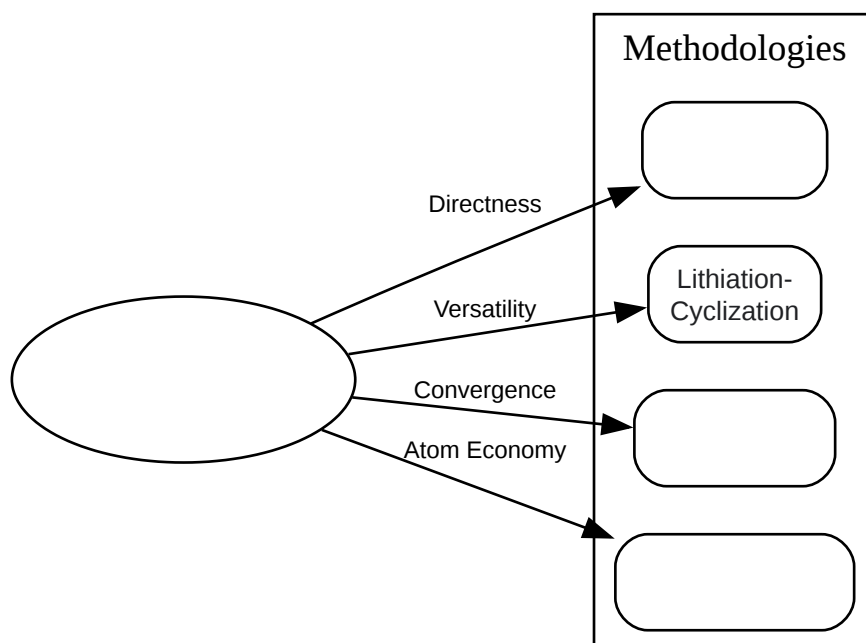

[Click to download full resolution via product page](#)

Caption: Strategic approaches to 3-functionalized 2-bromoquinolines.

For researchers seeking a direct route with good yields for 3-haloquinolines, electrophilic cyclization is an excellent choice. When a wide variety of C3-substituents are desired from a common intermediate, the lithiation-cyclization strategy offers unparalleled versatility, albeit with the need for more stringent reaction conditions. Palladium-catalyzed annulation provides a convergent and flexible approach, particularly for assembling the core from readily available building blocks. Finally, direct C-H functionalization represents the cutting edge of synthetic efficiency and holds immense promise for the future, with ongoing research likely to expand its applicability to this important scaffold.

The selection of the optimal synthetic route will ultimately depend on the specific target molecule, the availability of starting materials, and the desired scale of the synthesis. This guide provides the foundational knowledge and comparative data to make an informed decision, facilitating the advancement of research and development in fields that rely on these valuable quinoline derivatives.

References

- Zhang, X., Yao, T., & Larock, R. C. (2005). Synthesis of Substituted Quinolines by the Electrophilic Cyclization of N-(2-Alkynyl)anilines. *The Journal of Organic Chemistry*, 70(18), 7173–7183.
- Larock, R. C., & Yao, T. (2005). Synthesis of Substituted Quinolines by Electrophilic Cyclization of N-(2-Alkynyl)anilines. *Organic Letters*, 7(4), 541–544.
- Ökten, S., et al. (2023). Highly Brominated Quinolines: Synthesis, Characterization, and Investigation of Anticancer Activities Supported by Molecular Dynamics. *Molecules*, 28(9), 3853.
- Kobayashi, K., et al. (2016). Synthesis of 3-Bromoquinoline-2(1H)-thiones and 2-(Alkylsulfanyl)-3-bromoquinolines Based on the Reaction of 2-(2,2-Dibromoethenyl)phenyl Isothiocyanates with Butyllithium. *Heterocycles*, 95(1), 199.
- Meyet, C. E. (2013). Copper Catalyzed Three-Component Couplings Form Propargylamines and Quinolines. University of California, Davis.
- Ghorai, P., & Li, J. (2022). Recent Progress in Palladium-Catalyzed Quinoline Formation: Synthetic Applications and Mechanistic Insights. *Molecules*, 27(3), 993.
- Nagy, V., et al. (2022). Continuous Flow for the Photochemical Synthesis of 3-Substituted Quinolines. *Organic Process Research & Development*, 26(5), 1466–1473.
- Synfacts. (2016). Synthesis of 3-Bromoquinoline-2(1H)-thiones. *Synfacts*, 12(10), 1038.
- Ghaffari, B. (2016). Electrophilic Cyclization Reactions: Mechanism-Inspired Methods Development. University of California, Irvine.

- Kumar, I., & Sharma, R. (2024). Synthesis of quinoline mimics via C–H bond functionalization of quinoline: a review on recent progress. *Organic & Biomolecular Chemistry*, 22(1), 21-45.
- Yao, T., & Larock, R. C. (2005). Synthesis of Substituted Quinolines by Electrophilic Cyclization of N-(2-Alkynyl)anilines. *Organic Letters*, 7(4), 541-544.
- Kobayashi, K., et al. (2016). SYNTHESIS OF 3-BROMOQUINOLINE-2(1H)-THIONES AND 2-(ALKYLSULFANYL)-3-BROMOQUINOLINES BASED ON THE REACTION OF 2-(2,2-DIBROMOETHENYL)PHENYL ISOTHIOCYANATES WITH BUTYLLITHIUM. *HETEROCYCLES*, 95(1), 199-210.
- Mphahlele, M. J., & Maluleka, M. M. (2014). Palladium-Catalysed Synthesis and Transformation of Quinolones. *Molecules*, 19(8), 12585-12639.
- Ellman, J. A. C-H Functionalization.
- Dhiman, S., & Kim, J. (2024). Recent Developments in C–H Functionalization and Annulation of 2-Aryl-Quinazolinones and 3-Aryl-Quinazolinones via Site Selective Transformations. *Asian Journal of Organic Chemistry*.
- Larock, R. C., & Yao, T. (2005). Synthesis of Substituted Quinolines by Electrophilic Cyclization of N-(2-Alkynyl)anilines. Request PDF.
- Corio, A., Gravier-Pelletier, C., & Busca, P. (2021). Regioselective Functionalization of Quinolines through C-H Activation: A Comprehensive Review. *Molecules*, 26(18), 5467.
- Chen, J., et al. (2019). Palladium-Catalyzed Cascade Carbonylative Synthesis of Functionalized Isoquinoline-1,3-diones and Oxindoles Using Dimethyl Carbonate as a Green Solvent and Reactant.
- Wang, D., et al. (2020). Copper-catalyzed C–H/N–H cross-coupling reactions for the synthesis of 3-heteroaryl quinoxalin-2(1H)-ones. *Organic & Biomolecular Chemistry*, 18(30), 5853-5857.
- Mondal, S., & Ghorai, P. (2022). Cu(I)-Catalyzed Alkynylation of Quinolones. *Organic Letters*, 24(3), 633-638.
- Zhang, W., et al. (2020). Copper-Catalyzed Three-Component Synthesis of Quinolines via Oxidation and Aza-Diels-Alder Reaction. *Chinese Journal of Organic Chemistry*, 40(8), 2445-2452.
- ChemicalBook. (n.d.). 2-Bromoquinoline synthesis. ChemicalBook.
- Corio, A., Gravier-Pelletier, C., & Busca, P. (2021).
- Zhang, Y., et al. (2016). Palladium-catalyzed oxidative C–H activation/annulation of N-alkylanilines with bromoalkynes: access to functionalized 3-bromoindoles.
- Isaacs, A. K., et al. (2020). Copper-catalyzed three-component synthesis of pyrrole-substituted 1,2-dihydroisoquinolines. *Tetrahedron Letters*, 61(38), 152309.
- Sotorrios, L., & Vicario, J. L. (2021). C-3 functionalization of quinoxalin-2-ones and dihydroquinoxalin-2-ones. *Arkivoc*, 2022(1), 69-99.

- Kobayashi, K., et al. (2015). ChemInform Abstract: Synthesis of 3-Substituted 2-Bromoquinolines Utilizing 2-Bromo-3-lithioquinolines Generated by the Reaction of 2-(2,2-Dibromoethenyl)phenyl Isocyanides with Butyllithium. ChemInform, 46(27)*.
- Chen, Z., et al. (2023). Palladium-Catalyzed Cascade Reactions for Synthesis of Heterocycles Initiated by C(sp)

Need Custom Synthesis?

BenchChem offers custom synthesis for rare earth carbides and specific isotopic labeling.

Email: info@benchchem.com or [Request Quote Online](#).

Sources

- [1. Synthesis of Substituted Quinolines by the Electrophilic Cyclization of N-\(2-Alkynyl\)anilines - PMC \[pmc.ncbi.nlm.nih.gov\]](#)
- [2. researchgate.net \[researchgate.net\]](#)
- [3. researchgate.net \[researchgate.net\]](#)
- [4. pdfs.semanticscholar.org \[pdfs.semanticscholar.org\]](#)
- [5. Palladium-catalyzed oxidative C–H activation/annulation of N-alkylanilines with bromoalkynes: access to functionalized 3-bromoindoles - Chemical Communications \(RSC Publishing\) \[pubs.rsc.org\]](#)
- [6. mdpi.com \[mdpi.com\]](#)
- [7. Palladium-Catalysed Synthesis and Transformation of Quinolones - PMC \[pmc.ncbi.nlm.nih.gov\]](#)
- [8. Synthesis of quinoline mimics via C–H bond functionalization of quinoline: a review on recent progress - Organic & Biomolecular Chemistry \(RSC Publishing\) \[pubs.rsc.org\]](#)
- [9. C-H Functionalization | Ellman Laboratory \[ellman.chem.yale.edu\]](#)
- [10. Regioselective Functionalization of Quinolines through C-H Activation: A Comprehensive Review - PMC \[pmc.ncbi.nlm.nih.gov\]](#)
- [11. Regioselective Functionalization of Quinolines through C-H Activation: A Comprehensive Review - PubMed \[pubmed.ncbi.nlm.nih.gov\]](#)
- [12. researchgate.net \[researchgate.net\]](#)

- To cite this document: BenchChem. [A Comparative Guide to Alternative Syntheses of 3-Functionalized 2-Bromoquinolines]. BenchChem, [2026]. [Online PDF]. Available at: [<https://www.benchchem.com/product/b3262564/docs#a-comparative-guide-to-alternative-syntheses-of-3-functionalized-2-bromoquinolines>]

Disclaimer & Data Validity:

The information provided in this document is for Research Use Only (RUO) and is strictly not intended for diagnostic or therapeutic procedures. While BenchChem strives to provide accurate protocols, we make no warranties, express or implied, regarding the fitness of this product for every specific experimental setup.

Technical Support: The protocols provided are for reference purposes. Unsure if this reagent suits your experiment?

Need Industrial/Bulk Grade? [Request Custom Synthesis Quote](#)

BenchChem

Our mission is to be the trusted global source of essential and advanced chemicals, empowering scientists and researchers to drive progress in science and industry.

Contact

Address: 3281 E Guasti Rd
Ontario, CA 91761, United States
Phone: (601) 213-4426
Email: info@benchchem.com

[Contact our Ph.D. Support Team for a compatibility check](#)