

Reactivity of (Z)-3-Chloro-2-pentene

Author: BenchChem Technical Support Team. **Date:** December 2025

Compound of Interest

Compound Name: (Z)-3-Chloro-2-pentene

Cat. No.: B3261319

[Get Quote](#)

An In-depth Technical Guide on the Reactivity of **(Z)-3-Chloro-2-pentene**

For Researchers, Scientists, and Drug Development Professionals

Abstract

(Z)-3-chloro-2-pentene is a vinyl halide of interest for studying the influence of stereochemistry on chemical reactivity. This technical guide provides a comprehensive analysis of its core reactivity, focusing on reactions at the carbon-chlorine bond and the carbon-carbon double bond. Due to the limited availability of specific experimental literature for this compound, this document leverages established principles of organic chemistry to predict its behavior in nucleophilic substitution, elimination, and electrophilic addition reactions. Detailed reaction mechanisms are illustrated, and representative experimental protocols are provided as practical examples for laboratory application.

Introduction and Physicochemical Properties

(Z)-3-chloro-2-pentene is an organochlorine compound featuring a chlorine atom attached to an sp^2 -hybridized carbon, classifying it as a vinylic halide. The '(Z)' designation indicates that the higher priority groups on each side of the double bond (the chlorine and the adjacent methyl group) are on the same side. This defined stereochemistry makes it an excellent substrate for mechanistic studies in organic synthesis.

The reactivity of **(Z)-3-chloro-2-pentene** is primarily dictated by two functional sites: the vinylic carbon-chlorine bond and the electron-rich π -system of the alkene. Understanding the interplay

and competition between reaction pathways at these sites is crucial for its application as a synthetic intermediate.

Table 1: Physicochemical Properties of (Z)-3-chloro-2-pentene

Property	Value	Reference(s)
IUPAC Name	(Z)-3-chloropent-2-ene	[1]
CAS Number	34238-52-3	[1][2]
Molecular Formula	C ₅ H ₉ Cl	[1][3]
Molecular Weight	104.58 g/mol	[1][3]
Boiling Point	~103.8 °C (estimate)	[2]
Density	~0.906 g/mL at 25°C	[2]
Canonical SMILES	CCC(=C/C)Cl	[2]
InChIKey	VSQKJRIDGSFPSI- HYXAFXHYSA-N	[3][4]

Core Reactivity Profile

The reactivity of **(Z)-3-chloro-2-pentene** can be divided into two main categories: reactions involving the C-Cl bond and reactions involving the C=C double bond.

Reactions at the Vinylic C-Cl Bond

The direct substitution or elimination of the chlorine atom is challenging compared to its saturated (alkyl halide) counterparts.

Nucleophilic substitution reactions via standard S_N1 or S_N2 mechanisms are generally considered difficult for vinylic halides.[5][6]

- **S_N2 Infeasibility:** The S_N2 mechanism requires a backside attack by the nucleophile, which is sterically blocked by the electron density of the double bond and the molecule's planar geometry at the sp² center.

- S_N1 Infeasibility: The S_N1 mechanism would require the formation of a highly unstable vinylic carbocation. The positive charge on an sp -hybridized carbon is energetically unfavorable, making this pathway kinetically prohibitive under standard conditions.

While direct S_N1/S_N2 reactions are disfavored, substitution can sometimes occur under harsh conditions or via alternative pathways like addition-elimination or metal-catalyzed cross-coupling reactions, though specific data for **(Z)-3-chloro-2-pentene** is not readily available.

In the presence of a strong, non-nucleophilic base, **(Z)-3-chloro-2-pentene** is expected to undergo an elimination reaction to form an alkyne.[7] The most plausible pathway is an E2 mechanism, where a proton is abstracted from the adjacent carbon (C4), and the chloride ion is eliminated simultaneously to form a triple bond.

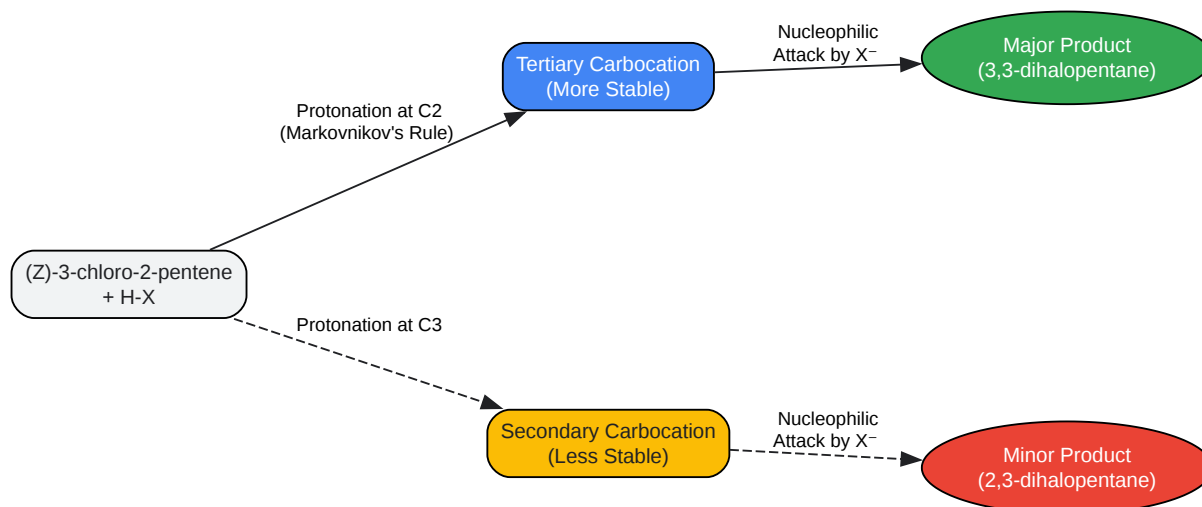

[Click to download full resolution via product page](#)

Need Custom Synthesis?

BenchChem offers custom synthesis for rare earth carbides and specific isotopic labeling.

Email: info@benchchem.com or [Request Quote Online](#).

References

- 1. (Z)-3-Chloro-2-pentene | C₅H₉Cl | CID 12705708 - PubChem [pubchem.ncbi.nlm.nih.gov]
- 2. (Z)-3-Chloro-2-pentene | lookchem [lookchem.com]
- 3. (Z)-3-chloro-2-pentene [webbook.nist.gov]
- 4. PubChemLite - (z)-3-chloro-2-pentene (C₅H₉Cl) [pubchemlite.lcsb.uni.lu]
- 5. dxhx.pku.edu.cn [dxhx.pku.edu.cn]
- 6. Nucleophilic substitution - Wikipedia [en.wikipedia.org]
- 7. organic chemistry - Elimination from Vinylic Halides - Chemistry Stack Exchange [chemistry.stackexchange.com]
- To cite this document: BenchChem. [Reactivity of (Z)-3-Chloro-2-pentene]. BenchChem, [2025]. [Online PDF]. Available at: [https://www.benchchem.com/product/b3261319#reactivity-of-z-3-chloro-2-pentene]

Disclaimer & Data Validity:

The information provided in this document is for Research Use Only (RUO) and is strictly not intended for diagnostic or therapeutic procedures. While BenchChem strives to provide accurate protocols, we make no warranties, express or implied, regarding the fitness of this product for every specific experimental setup.

Technical Support: The protocols provided are for reference purposes. Unsure if this reagent suits your experiment? [[Contact our Ph.D. Support Team for a compatibility check](#)]

Need Industrial/Bulk Grade? [Request Custom Synthesis Quote](#)

BenchChem

Our mission is to be the trusted global source of essential and advanced chemicals, empowering scientists and researchers to drive progress in science and industry.

Contact

Address: 3281 E Guasti Rd

Ontario, CA 91761, United States

Phone: (601) 213-4426

Email: info@benchchem.com