

# Application Note: Scalable Synthesis of 3-Ethyl-4-iodoaniline

**Author:** BenchChem Technical Support Team. **Date:** April 2026

## Compound of Interest

Compound Name: 3-Ethyl-4-iodoaniline

CAS No.: 337980-54-8

Cat. No.: B3261023

[Get Quote](#)

## Abstract & Strategic Overview

**3-Ethyl-4-iodoaniline** is a high-value halogenated aniline intermediate, critical for "scaffold hopping" in drug discovery. It serves as a precursor for Suzuki-Miyaura, Sonogashira, and Buchwald-Hartwig cross-coupling reactions, allowing the installation of complex heterocycles or alkyl chains ortho to the ethyl group.

The synthesis of this molecule presents a classic regioselectivity challenge. The amino group (-NH

) at position 1 is a strong activator and ortho, para-director. The ethyl group (-Et) at position 3 is a weak activator and ortho, para-director.

- Target Position (C4): Para to the amine and ortho to the ethyl group.
- Competing Position (C6): Ortho to the amine and para to the ethyl group.

Strategic Insight: While steric hindrance at C4 (flanked by the ethyl group) is non-negligible, the electronic resonance contribution of the amino group overwhelmingly favors para-substitution.

Therefore, a direct electrophilic iodination under mild, controlled conditions is the most efficient route, avoiding the need for protecting groups or multi-step Sandmeyer sequences.

## Retrosynthetic Analysis & Route Selection

The most robust pathway utilizes electrophilic aromatic substitution using elemental iodine activated by mild base or iodine monochloride.

- Route A (Green Protocol): Iodine ( ) + Sodium Bicarbonate ( ) in Water/Methanol.
  - Pros: High atom economy, aqueous solvent, mild pH, minimizes oxidation of the aniline.
  - Cons: Requires careful temperature control to prevent over-iodination.
- Route B (High Reactivity Protocol): Iodine Monochloride ( ) in Acetic Acid ( ).
  - Pros: Extremely fast, high conversion for unreactive substrates.
  - Cons: Corrosive reagents, higher risk of di-iodination.

Selected Protocol: Route A is recommended for initial scale-up (1g to 100g) due to its operational safety and ease of purification.

## Reaction Logic Visualization

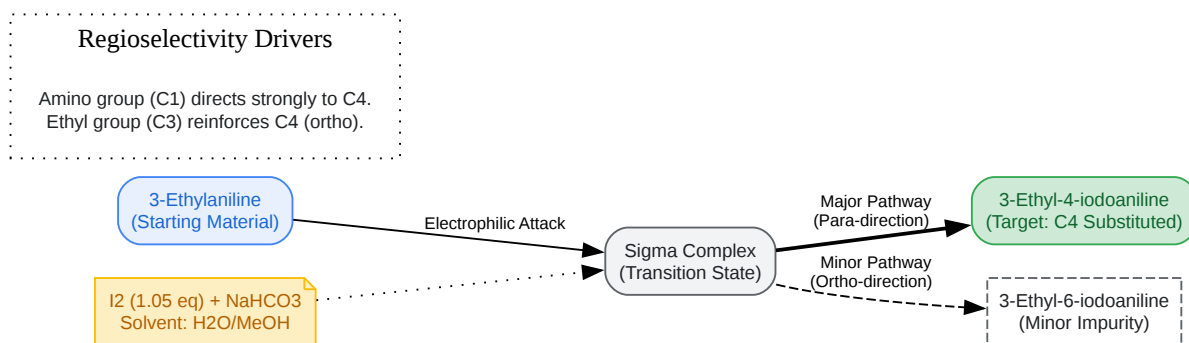

[Click to download full resolution via product page](#)

Caption: Mechanistic pathway showing the convergence of directing effects toward the C4 position.[1]

## Detailed Experimental Protocol

### Method A: Bicarbonate-Buffered Direct Iodination (Recommended)

This protocol minimizes the formation of di-iodo byproducts by maintaining a slightly basic pH, which neutralizes the HI generated during the reaction, preventing acid-catalyzed side reactions.

#### Materials & Equipment

- Reagents:
    - 3-Ethylaniline (purity >98%)
    - Iodine (resublimed, solid)
    - Sodium Bicarbonate (
- ) [2][3]

- Solvents: Methanol (MeOH), Deionized Water, Ethyl Acetate (EtOAc), Sodium Thiosulfate ( ).
- Equipment:
  - 3-neck Round Bottom Flask (RBF) equipped with a mechanical stirrer (magnetic stirring is insufficient for slurries).
  - Addition funnel (pressure-equalizing).
  - Internal thermometer.

## Step-by-Step Procedure

- Preparation of the Substrate Solution:
  - In the 3-neck RBF, dissolve 3-Ethylaniline (12.1 g, 100 mmol) in Methanol (50 mL) and Water (50 mL).
  - Add solid Sodium Bicarbonate (12.6 g, 150 mmol, 1.5 eq).
  - Note: The mixture may form a suspension. This is normal.
  - Cool the mixture to 0–5°C using an ice/water bath.
- Controlled Addition of Iodine:
  - Prepare a solution of Iodine (25.4 g, 100 mmol, 1.0 eq) in Methanol (100 mL). Tip: If iodine dissolves slowly, add a small amount of KI to solubilize it, though pure MeOH usually suffices.
  - Transfer the iodine solution to the addition funnel.
  - Crucial Step: Add the iodine solution dropwise to the aniline mixture over 45–60 minutes.
  - Control: Maintain internal temperature below 10°C. Rapid addition leads to local hotspots and di-iodination.

- Reaction Monitoring:
  - Once addition is complete, allow the reaction to warm to Room Temperature (20–25°C).
  - Stir for 2–3 hours.
  - TLC Check: Silica gel, 10% EtOAc in Hexanes.
    - Starting Material (3-Ethylaniline): Higher  
.
    - Product (**3-Ethyl-4-iodoaniline**): Lower  
, stains dark with UV/Iodine.
  - Endpoint: The reaction is complete when the starting aniline is consumed (<2%).
- Workup & Isolation:
  - Quench: Pour the reaction mixture into 200 mL of ice-cold water containing Sodium Thiosulfate (5 g). Stir for 15 minutes.
    - Visual Cue: The dark brown iodine color should fade to a pale yellow/orange.
  - Extraction: Extract the aqueous mixture with Ethyl Acetate ( mL).
  - Washing: Combine organic layers and wash with:
    1. Water ( mL)
    2. Brine ( mL)
  - Drying: Dry over anhydrous Sodium Sulfate (

).[2][4][5] Filter and concentrate under reduced pressure (Rotavap) to yield a dark oil or solid.

- Purification:
  - The crude material often contains traces of the 6-iodo isomer.
  - Recrystallization (Preferred): Dissolve the crude solid in minimal hot Ethanol (approx. 2-3 mL/g). Add water dropwise until turbidity persists. Cool slowly to 4°C. Filter the needles.
  - Flash Chromatography (Alternative): If the product is an oil, purify on Silica Gel (Gradient: 0% 10% EtOAc in Hexanes).

## Analytical Validation

Test	Expected Result	Diagnostic Notes
Appearance	Off-white to light brown crystalline solid	Darkens upon air/light exposure (store in amber vials).
<sup>1</sup> H NMR (CDCl <sub>3</sub> )	7.50 (d, J=8.5 Hz, 1H, H-5), 6.60 (d, J=2.5 Hz, 1H, H-2), 6.45 (dd, 1H, H-6), 3.5 (br s, 2H, NH <sub>2</sub> ), 2.6 (q, 2H, CH <sub>2</sub> ), 1.2 (t, 3H, CH <sub>3</sub> ).	Key: The doublet at ~7.50 ppm corresponds to the proton ortho to the Iodine (H-5). The coupling constant (~8.5 Hz) indicates ortho coupling to H-6, confirming the para substitution pattern relative to the amine.
MS (ESI+)	[M+H] <sup>+</sup> = 248.0	Characteristic Iodine isotope pattern is not split (monoisotopic), but mass defect is significant.
Melting Point	45–48 °C	Sharp range indicates high purity.

## Troubleshooting & Optimization (Expertise)

### "The reaction stalled at 80% conversion."

Cause: Iodine is less reactive in pure methanol/water as the reaction progresses. Solution: Do not add more Iodine immediately. Instead, add 10% more NaHCO<sub>3</sub> to ensure the HI byproduct is neutralized, pushing the equilibrium forward. If still stalled after 1 hour, add 0.1 eq of Iodine.

### "I see a significant di-iodo impurity."

Cause: Localized high concentration of iodine during addition. Solution: Improve stirring speed (vortex formation) and dilute the iodine feed further. Ensure the temperature stays strictly at 0°C during addition.

### "The product is an oil that won't crystallize."

Cause: Residual solvent or isomer mixture.<sup>[5]</sup> Solution: Perform a "seed" recrystallization. Dissolve in Hexanes, cool to -20°C, and scratch the glass. If it remains oil, convert to the HCl salt (add HCl in ether) which is usually a stable solid, then neutralize back to free base when needed.

## Process Workflow Diagram

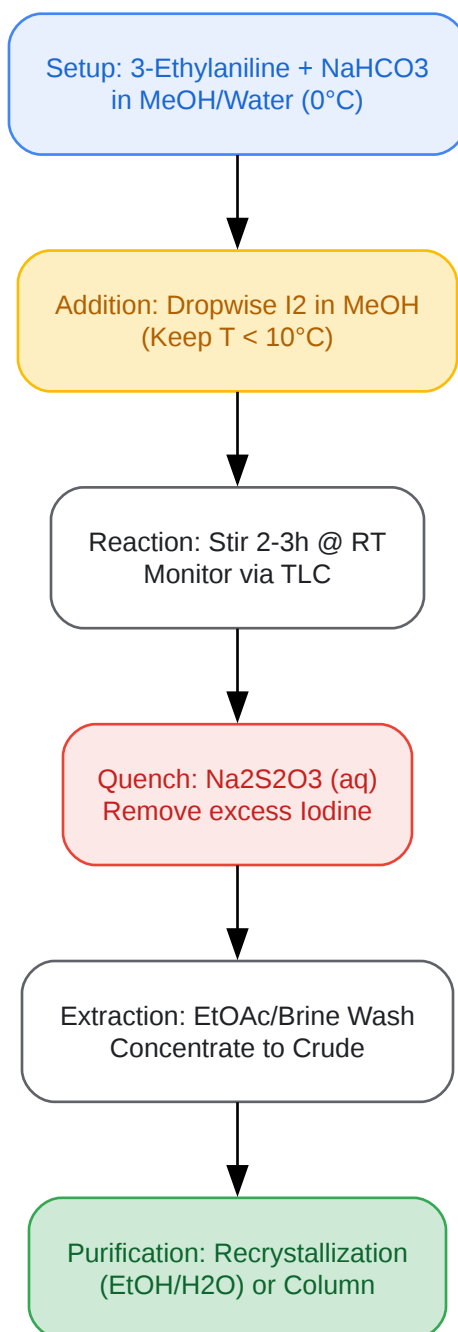

[Click to download full resolution via product page](#)

Caption: Operational workflow for the synthesis of **3-Ethyl-4-iodoaniline**.

## References

- Organic Syntheses Procedure for p-Iodoaniline.
  - Source: Organic Syntheses, Coll. Vol. 2, p.347 (1943).

- Relevance: Establishes the foundational protocol for aniline iodination
- URL:[\[Link\]](#)
- BenchChem Technical Support: Synthesis of 4-Iodo-3,5-dimethylaniline.
  - Source: BenchChem Application Notes (2025).[\[2\]](#)[\[5\]](#)
  - Relevance: Validates the regioselectivity in 3,5-dialkyl systems and scale-up parameters for similar sterically hindered anilines.
- Regioselective Iodination
  - Source: Tetrahedron Letters, Vol 40, Issue 33, 1999.
  - Relevance: Discusses the directing effects of alkyl groups versus amino groups in electrophilic iodination
  - URL:[\[Link\]](#)

### Need Custom Synthesis?

BenchChem offers custom synthesis for rare earth carbides and specific isotopic labeling.

Email: [info@benchchem.com](mailto:info@benchchem.com) or [Request Quote Online](#).

## Sources

- [1. researchgate.net \[researchgate.net\]](#)
- [2. pdf.benchchem.com \[pdf.benchchem.com\]](#)
- [3. Organic Syntheses Procedure \[orgsyn.org\]](#)
- [4. pdf.benchchem.com \[pdf.benchchem.com\]](#)
- [5. pdf.benchchem.com \[pdf.benchchem.com\]](#)
- To cite this document: BenchChem. [Application Note: Scalable Synthesis of 3-Ethyl-4-iodoaniline]. BenchChem, [2026]. [Online PDF]. Available at: [\[https://www.benchchem.com/product/b3261023/docs#application-note-scalable-synthesis-of-3-ethyl-4-iodoaniline\]](https://www.benchchem.com/product/b3261023/docs#application-note-scalable-synthesis-of-3-ethyl-4-iodoaniline)

**Disclaimer & Data Validity:**

The information provided in this document is for Research Use Only (RUO) and is strictly not intended for diagnostic or therapeutic procedures. While BenchChem strives to provide accurate protocols, we make no warranties, express or implied, regarding the fitness of this product for every specific experimental setup.

**Technical Support:** The protocols provided are for reference purposes. Unsure if this reagent suits your experiment?

**Need Industrial/Bulk Grade?** [Request Custom Synthesis Quote](#)

## BenchChem

Our mission is to be the trusted global source of essential and advanced chemicals, empowering scientists and researchers to drive progress in science and industry.

### Contact

Address: 3281 E Guasti Rd  
Ontario, CA 91761, United States  
Phone: (601) 213-4426  
Email: [info@benchchem.com](mailto:info@benchchem.com)

[Contact our Ph.D. Support Team for a compatibility check](#)