

# Part 1: Executive Summary & Mechanistic Insight

**Author:** BenchChem Technical Support Team. **Date:** April 2026

## Compound of Interest

Compound Name: 1,2-Diphenoxybenzene

CAS No.: 3379-37-1

Cat. No.: B3260994

[Get Quote](#)

The synthesis of biaryl ethers (diaryl ethers) is a cornerstone of medicinal chemistry, featuring prominently in vancomycin antibiotics and various kinase inhibitors. However, the introduction of steric hindrance—specifically ortho-substituents on either the aryl halide or the phenol—dramatically suppresses the efficiency of classical methods.

Traditional S<sub>N</sub>Ar requires strong electron-withdrawing groups, while classical copper-mediated Ullmann coupling often necessitates harsh temperatures (>120°C) that degrade sensitive functional groups.

The Solution: The industry standard for synthesizing sterically hindered biaryl ethers (up to tetra-ortho substitution) is Palladium-catalyzed cross-coupling utilizing dialkylbiaryl phosphine ligands (Buchwald-type).

## The Mechanistic Bottleneck: Reductive Elimination

In unhindered systems, oxidative addition is often rate-limiting. However, in sterically crowded C–O coupling, the catalytic cycle usually stalls at reductive elimination. The Pd(II) intermediate is stabilized by the electron-rich phenol, and the steric bulk prevents the necessary orbital overlap for bond formation.

Why Bulky Ligands Work: Ligands like RockPhos and tBuBrettPhos are designed to be exceptionally bulky. This bulk exerts steric pressure on the Pd(II) center, destabilizing the ground state of the intermediate and forcing the aryl and phenoxide groups closer together. This acceleration of reductive elimination outcompetes side reactions like protodehalogenation.

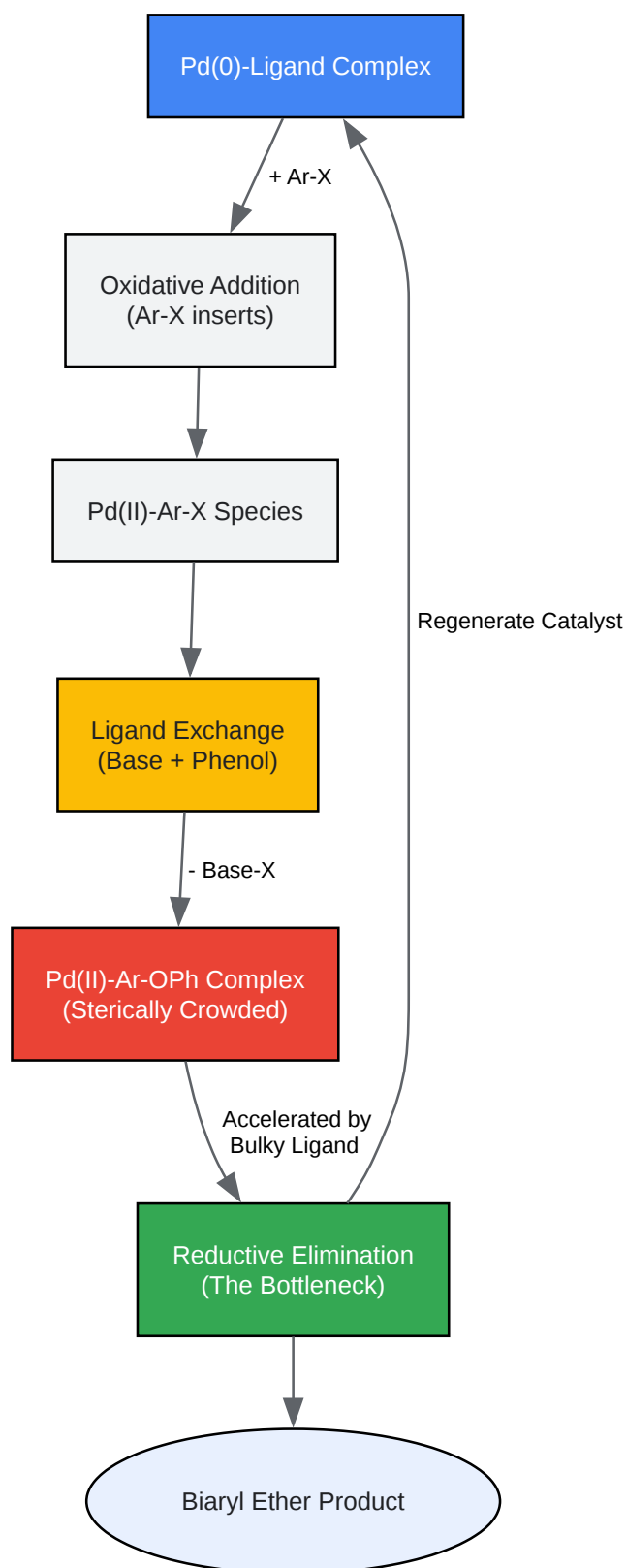

[Click to download full resolution via product page](#)

Figure 1: The Pd-Catalyzed C-O Coupling Cycle. Note that for hindered ethers, the Reductive Elimination step (Green) is critical and driven by ligand bulk.

## Part 2: Strategic Decision Matrix

Before selecting a protocol, evaluate your substrate electronic and steric profile.

Feature	Method A: Pd-Catalyzed (RockPhos)	Method B: Cu-Catalyzed (Modern Ullmann)	Method C: SNAr
Primary Utility	Highly Hindered (3-4 ortho groups)	Moderately Hindered (1-2 ortho groups)	Electron-Deficient Electrophiles
Electronic Bias	Works on Electron-Rich & Poor	Best with Electron-Deficient Halides	Requires Strong EWG (NO <sub>2</sub> , CN)
Temperature	Mild (50–90 °C)	High (90–120 °C)	Variable (RT–100 °C)
Cost	High (Pd + Ligand)	Low (Cu salt)	Low
Key Limitation	Cost; Air-sensitive setup	Protodehalogenation side-products	Limited substrate scope

## Part 3: Detailed Protocols

### Protocol A: The "RockPhos" System (For Highly Hindered Substrates)

Best for: Tetra-ortho substituted systems or electron-rich aryl halides.

Materials:

- Catalyst Precursor: [(cinnamyl)PdCl]<sub>2</sub> (Preferred over Pd<sub>2</sub>(dba)<sub>3</sub> for faster activation) or Pd(OAc)<sub>2</sub>.
- Ligand: RockPhos (CAS: 1269219-98-6) or tBuBrettPhos (CAS: 1160861-53-9).
- Base: Cs<sub>2</sub>CO<sub>3</sub> (Cesium Carbonate) - Must be dry/granular.

- Solvent: Toluene (anhydrous).

#### Step-by-Step Procedure:

- Preparation (Glovebox or Schlenk Line):
  - In a 4 mL screw-top vial equipped with a magnetic stir bar, add the Aryl Halide (1.0 equiv, e.g., 1.0 mmol).
  - Add the Phenol (1.2 equiv).
  - Add Cs<sub>2</sub>CO<sub>3</sub> (1.5 equiv). Note: Grind the base if it is clumpy to ensure surface area.
  - Add RockPhos (3.0 – 4.5 mol%).
  - Add [(cinnamyl)PdCl]<sub>2</sub> (1.0 – 1.5 mol%). Note: The Pd:Ligand ratio should be 1:1.5 to 1:2.
- Solvent Addition:
  - Add anhydrous Toluene (concentration 0.2 M to 0.5 M relative to halide).
  - Self-Validation Check: If using a Schlenk line, freeze-pump-thaw the solvent x3 to remove oxygen, which kills the active Pd(0) species.
- Reaction:
  - Seal the vial with a PTFE-lined cap.
  - Heat to 90 °C in a pre-heated aluminum block.
  - Stir vigorously (800+ rpm). Mass transfer is critical in heterogeneous base mixtures.
  - Run for 12–24 hours.
- Workup:
  - Cool to room temperature.[\[1\]](#)

- Dilute with Ethyl Acetate (EtOAc) and filter through a small pad of silica or Celite to remove Pd black and salts.
- Concentrate in vacuo.
- Purify via flash column chromatography (typically Hexanes/EtOAc).

Why this works: RockPhos is bulky enough to force the reductive elimination of even 2,6-dimethylphenol coupled with 2,6-dimethylbromobenzene.

## Protocol B: Modern Copper-Catalyzed System

Best for: Cost-sensitive scale-up of moderately hindered systems.

Materials:

- Catalyst: CuI (Copper(I) Iodide).
- Ligand: Picolinic Acid or 2,2,6,6-tetramethyl-3,5-heptanedione (TMHD).
- Base: K<sub>3</sub>PO<sub>4</sub> (Potassium Phosphate).
- Solvent: DMSO or DMF (Polar aprotic solvents are required for Cu-catalysis).

Step-by-Step Procedure:

- Assembly:
  - Charge a reaction tube with CuI (10 mol%), Ligand (20 mol%), Aryl Iodide (1.0 equiv), Phenol (1.2 equiv), and K<sub>3</sub>PO<sub>4</sub> (2.0 equiv).
- Solvent:
  - Add DMSO (1.0 M concentration).
- Reaction:
  - Heat to 110–120 °C. Note: Copper catalysis has a higher activation energy than Palladium.

- Monitor by HPLC/LC-MS.
- Workup:
  - Critical Step: Dilute with water and extract with EtOAc. Wash the organic layer 3x with water to remove DMSO, which can interfere with chromatography.

## Part 4: Troubleshooting & Self-Validation

Use this logic flow to diagnose failure modes.

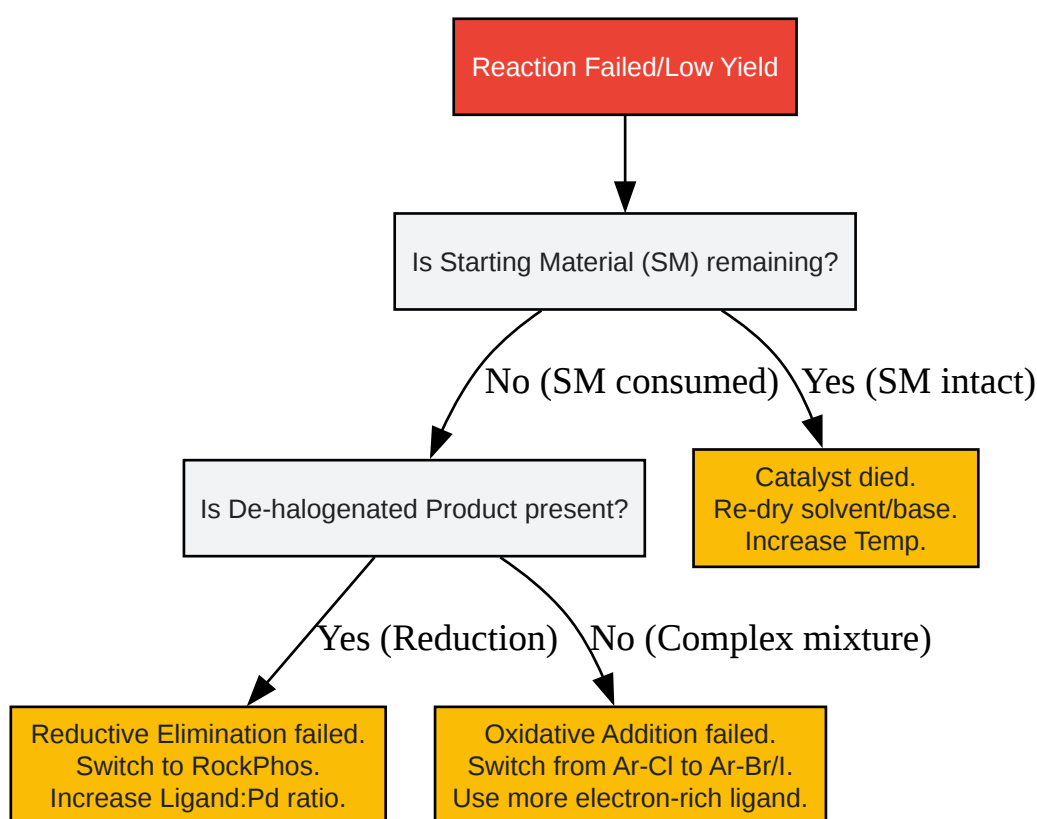

[Click to download full resolution via product page](#)

Figure 2: Troubleshooting Logic Flow.

Validation Checkpoints:

- Color Change: The Pd reaction mixture should typically turn from dark red/brown to black (Pd black precipitation) only after the reaction is complete. Early precipitation indicates catalyst decomposition (oxygen leak or poor ligand binding).

- Dehalogenation: If you observe the aryl halide converting to the simple arene (Ar-H), the reductive elimination is too slow. Action: Switch to a bulkier ligand (RockPhos) or lower the temperature to suppress  $\beta$ -hydride elimination (if alcohol solvent) or protodehalogenation.

## References

- Buchwald, S. L., et al. (2012). An Improved Synthesis of BrettPhos- and RockPhos-Type Biarylphosphine Ligands. *Advanced Synthesis & Catalysis*.
- Buchwald, S. L., et al. (2011). A New Biarylphosphine Ligand for the Pd-Catalyzed Synthesis of Diaryl Ethers under Mild Conditions. *Organic Letters*.
- Wolf, C. & Xu, H. (2008).[2] Efficient Synthesis of Sterically Crowded Biaryls by Palladium-Phosphinous Acid-Catalyzed Cross-Coupling. *Journal of Organic Chemistry*.
- Sigma-Aldrich. (n.d.). tBuBrettPhos Product Sheet and Application Guide.

### *Need Custom Synthesis?*

*BenchChem offers custom synthesis for rare earth carbides and specific isotopic labeling.*

*Email: [info@benchchem.com](mailto:info@benchchem.com) or [Request Quote Online](#).*

## Sources

- 1. [jmcct.com](http://jmcct.com) [[jmcct.com](http://jmcct.com)]
- 2. Efficient Synthesis of Sterically Crowded Biaryls by Palladium-Phosphinous Acid-Catalyzed Cross-Coupling of Aryl Halides and Aryl Grignards [[organic-chemistry.org](http://organic-chemistry.org)]
- To cite this document: BenchChem. [Part 1: Executive Summary & Mechanistic Insight]. BenchChem, [2026]. [Online PDF]. Available at: [<https://www.benchchem.com/product/b3260994/docs#part-1-executive-summary-mechanistic-insight>]

### **Disclaimer & Data Validity:**

The information provided in this document is for Research Use Only (RUO) and is strictly not intended for diagnostic or therapeutic procedures. While BenchChem strives to provide

accurate protocols, we make no warranties, express or implied, regarding the fitness of this product for every specific experimental setup.

**Technical Support:** The protocols provided are for reference purposes. Unsure if this reagent suits your experiment?

**Need Industrial/Bulk Grade?** [Request Custom Synthesis Quote](#)

## BenchChem

Our mission is to be the trusted global source of essential and advanced chemicals, empowering scientists and researchers to drive progress in science and industry.

### Contact

Address: 3281 E Guasti Rd

Ontario, CA 91761, United States

Phone: (601) 213-4426

Email: [info@benchchem.com](mailto:info@benchchem.com)

[Contact our Ph.D. Support Team for a compatibility check](#)