

Technical Guide: Reactivity & Applications of 2-(2-Bromoethyl)-1,3-Dioxane

Author: BenchChem Technical Support Team. **Date:** May 2026

Compound of Interest

Compound Name: 4-(Bromomethyl)-1,3-dioxane

CAS No.: 31100-39-7

Cat. No.: B3258905

[Get Quote](#)

Executive Summary

The integration of a primary alkyl bromide within a 1,3-dioxane scaffold—most notably 2-(2-bromoethyl)-1,3-dioxane—provides a strategic "masked" aldehyde handle for modular drug synthesis.^[1] Unlike simple alkyl halides, this scaffold possesses a duality of reactivity: it functions as a robust electrophile in

reactions and a nucleophile precursor (via Grignard formation), all while the 1,3-dioxane moiety acts as a stable protecting group for the carbonyl functionality.^[1]

This guide analyzes the physicochemical properties, reaction kinetics, and stability profiles of this scaffold, offering validated protocols for its deployment in fragment-based drug discovery (FBDD).

Structural & Electronic Context

The Scaffold Architecture

The 1,3-dioxane ring is a six-membered cyclic acetal.^[2] Compared to its five-membered analog (1,3-dioxolane), the 1,3-dioxane is thermodynamically more stable toward acidic

hydrolysis, making it the preferred protecting group for multi-step syntheses where pH fluctuations are unavoidable.[1]

Key Structural Features:

- Primary Bromide Handle: Located at the

-position relative to the acetal center (in the 2-ethyl derivative). This distance minimizes the inductive electron-withdrawing effects of the ring oxygens, allowing the bromide to retain standard primary alkyl halide reactivity ().
- Acetal "Mask": The C2 carbon is

hybridized, protecting the latent aldehyde.
- Conformation: The ring adopts a chair conformation.[2] Substituents at C2 (the bromoethyl chain) prefer the equatorial position to minimize 1,3-diaxial interactions, stabilizing the molecule during thermal ramp-ups required for Grignard initiation.

Stability Matrix

The utility of this scaffold is defined by its orthogonality. It survives conditions that destroy aldehydes but yields the aldehyde upon specific activation.

Condition	Stability	Notes
Aqueous Acid (pH < 4)	Labile	Rapid hydrolysis to 3-bromopropionaldehyde and 1,3-propanediol.
Lewis Acids (,)	Labile	Promotes ring opening or transacetalization.
Aqueous Base (NaOH, KOH)	Stable	Resistant to hydrolysis even at elevated temperatures.
Nucleophiles (,)	Stable	Ring remains intact; reaction occurs exclusively at the C-Br bond.
Reducing Agents (,)	Stable	Acetal oxygen lone pairs do not coordinate strongly enough to facilitate opening.
Organometallics (,)	Stable	The acetal proton is not acidic enough for deprotonation.

Reactivity Profile I: Nucleophilic Substitution ()

The primary alkyl bromide is a potent electrophile. The reaction follows standard second-order kinetics ().

Heteroatom Alkylation

The scaffold is extensively used to append the protected aldehyde chain to amines, phenols, and thiols.

- Solvent Choice: Polar aprotic solvents (DMF, DMSO, NMP) are required to solvate the cation and leave the nucleophile "naked" and reactive.
- Finkelstein Activation: For sluggish nucleophiles, the in situ conversion of the bromide to an iodide using catalytic NaI (10-20 mol%) in acetone or MEK significantly accelerates the rate ().

Carbon-Carbon Bond Formation (Alkylation)

Reaction with stabilized carbanions (e.g., enolates, dithianes) proceeds smoothly.

- Critical Constraint: The base used to generate the enolate must not be strong enough to cause elimination of the bromide. However, since the α -protons are not activated by a carbonyl, elimination is generally slow compared to substitution.

Reactivity Profile II: Organometallic Utility (Grignard)

The "Killer App" of this scaffold is its conversion into a Grignard reagent, (2-(1,3-dioxan-2-yl)ethyl)magnesium bromide. This effectively reverses the polarity (umpolung) of the chain, turning an electrophilic bromide into a nucleophilic aldehyde equivalent.

Formation Challenges & Solutions

Formation of the Grignard reagent from the bromide can be sluggish due to the potential coordination of the magnesium species to the dioxane oxygens, which can form stable, unreactive chelates on the metal surface.

- Entrainment: Use of 1,2-dibromoethane (DBE) or iodine is mandatory to etch the Mg oxide layer.
- Temperature: Reflux is often required to sustain the radical mechanism of insertion.

Reaction Workflow Diagram

The following diagram illustrates the critical decision pathways for utilizing this scaffold.

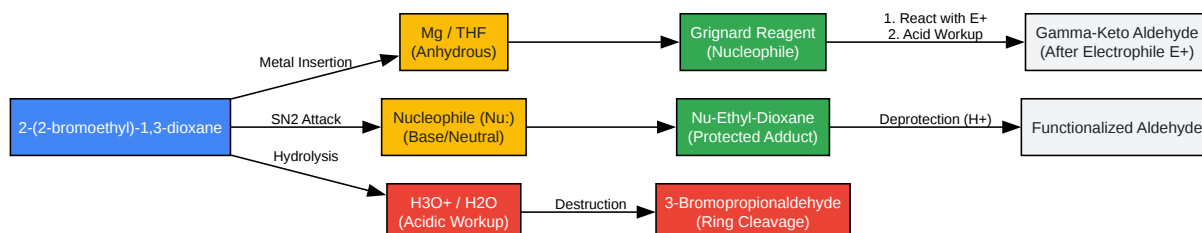

[Click to download full resolution via product page](#)

Figure 1: Decision tree for reaction pathways. Note the orthogonality: Acid destroys the scaffold, while Base/Metal utilizes it.

Experimental Protocols

Protocol A: Preparation of the Grignard Reagent

This protocol produces the nucleophilic "masked aldehyde" species.

Reagents:

- Magnesium turnings (1.2 equiv), oven-dried.
- 2-(2-bromoethyl)-1,3-dioxane (1.0 equiv).
- THF (Anhydrous, stabilizer-free).
- Iodine (crystal) or 1,2-Dibromoethane (catalytic).

Method:

- Activation: Place Mg turnings in a flame-dried 3-neck flask under Argon. Add a single crystal of iodine and heat gently with a heat gun until iodine vaporizes, activating the Mg surface.

- Initiation: Add just enough THF to cover the Mg. Add 5% of the total volume of the bromide. If the reaction does not start (exotherm/color change), add 2 drops of 1,2-dibromoethane.
- Addition: Once initiated, dilute the remaining bromide in THF (1M concentration). Add dropwise to the refluxing mixture over 1 hour.
- Digestion: Reflux for an additional 2 hours to ensure complete consumption of the bromide.
- Titration: Titrate a small aliquot to determine precise concentration before use.

Protocol B: Standard Nucleophilic Substitution (Amine Alkylation)

This protocol appends the scaffold to a secondary amine.

Reagents:

- Secondary Amine (1.0 equiv).
- 2-(2-bromoethyl)-1,3-dioxane (1.1 equiv).
- (2.0 equiv, anhydrous).
- Acetonitrile or DMF (0.2 M).
- NaI (0.1 equiv) - Optional accelerator.

Method:

- Suspend the amine and
in the solvent.
- Add the bromide and NaI.
- Heat to 60-80°C. Monitor by TLC/LCMS. (Reaction typically takes 4-12 hours).
- Workup: Filter off solids. Dilute filtrate with EtOAc, wash with water (

) to remove DMF. Dry organic layer over

.^[3]

- Purification: Flash chromatography. Note: Silica gel is slightly acidic; add 1% triethylamine to the eluent to prevent acetal hydrolysis on the column.

Deprotection Strategy

Once the C-C or C-N bond is formed, the aldehyde must be revealed.

- Standard Method: Dissolve the protected intermediate in Acetone/Water (4:1). Add catalytic -Toluenesulfonic acid (pTsOH) or 1M HCl. Stir at RT. The acetone acts as a transacetalization acceptor, driving the equilibrium toward the product aldehyde.
- Workup: Neutralize with saturated before extraction to prevent aldol condensation of the newly liberated aldehyde.

Mechanism of Action: Grignard Formation

The formation of the Grignard reagent involves a single electron transfer (SET) mechanism on the Mg surface.

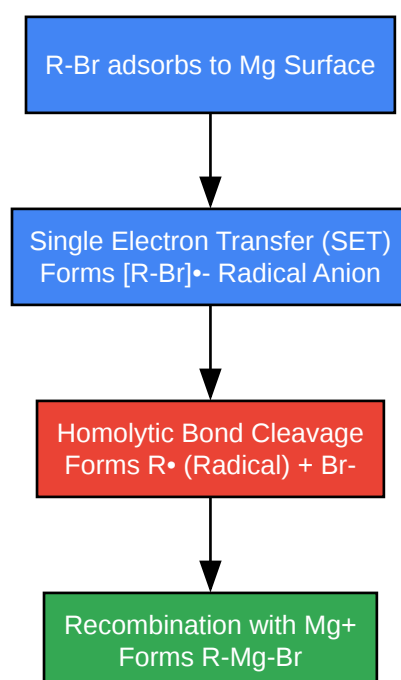

[Click to download full resolution via product page](#)

Figure 2: Radical mechanism of Grignard formation on the Magnesium surface.

References

- Ningbo Inno Pharmchem. (2024).[1] The Synthetic Utility of 2-(2-Bromoethyl)-1,3-dioxane in Organic Chemistry. Retrieved from [[Link](#)]
- Organic Chemistry Portal. (n.d.). Protection of Carbonyl Compounds: 1,3-Dioxanes. Retrieved from [[Link](#)]
- Stowell, J. C. (1990). Carbanions II: Grignard Reagents from Haloacetals. Chemical Reviews, 90(5). (Contextual citation based on general reactivity described in search results).

Need Custom Synthesis?

BenchChem offers custom synthesis for rare earth carbides and specific isotopic labeling.

Email: info@benchchem.com or [Request Quote Online](#).

Sources

- 1. nbinno.com [nbinno.com]
- 2. [Thieme E-Books & E-Journals](http://thieme-connect.de) [thieme-connect.de]
- 3. [2-\(2-Bromoethyl\)-1,3-dioxolane synthesis - chemicalbook](http://chemicalbook.com) [chemicalbook.com]
- To cite this document: BenchChem. [Technical Guide: Reactivity & Applications of 2-(2-Bromoethyl)-1,3-Dioxane]. BenchChem, [2026]. [Online PDF]. Available at: [<https://www.benchchem.com/product/b3258905/docs#technical-guide-reactivity-applications-of-2-2-bromoethyl-1-3-dioxane>]

Disclaimer & Data Validity:

The information provided in this document is for Research Use Only (RUO) and is strictly not intended for diagnostic or therapeutic procedures. While BenchChem strives to provide

accurate protocols, we make no warranties, express or implied, regarding the fitness of this product for every specific experimental setup.

Technical Support: The protocols provided are for reference purposes. Unsure if this reagent suits your experiment?

Need Industrial/Bulk Grade? [Request Custom Synthesis Quote](#)

BenchChem

Our mission is to be the trusted global source of essential and advanced chemicals, empowering scientists and researchers to drive progress in science and industry.

Contact

Address: 3281 E Guasti Rd

Ontario, CA 91761, United States

Phone: (601) 213-4426

Email: info@benchchem.com

[Contact our Ph.D. Support Team for a compatibility check](#)