

Comparative Bioactivity Guide: D-Pro vs. (4R)-4-methyl-D-Pro Analogs

Author: BenchChem Technical Support Team. **Date:** May 2026

Compound of Interest

Compound Name: (4R)-4-METHYL-D-PROLINE HCL

CAS No.: 31137-95-8

Cat. No.: B3258923

[Get Quote](#)

Executive Summary

In the optimization of peptidomimetics, the substitution of D-Proline (D-Pro) with (4R)-4-methyl-D-Proline represents a high-precision strategy to modulate backbone conformation and proteolytic stability. While D-Pro is widely used to induce

-turns and evade L-specific proteases, the addition of a methyl group at the C4 position introduces a "steric lock."

This guide analyzes the structural and bioactive consequences of this substitution.^{[1][2]} The core differentiator is the "Methyl Switch": the (4R)-methyl substituent on the D-pyrrolidine ring forces a reversal of the ring pucker preference, altering the

and

torsion angles and, consequently, the peptide's secondary structure and receptor affinity.

Mechanistic Comparison: The "Methyl Switch"

The bioactivity difference between D-Pro and (4R)-4-methyl-D-Pro is driven by stereoelectronic and steric effects that dictate the pyrrolidine ring pucker (

-endo vs.

-exo).

Conformational Dynamics

- D-Proline (Unsubstituted): In solution, the pyrrolidine ring of D-Pro exists in a rapid equilibrium between
 - endo (down) and
 - exo (up) puckers, with a slight energetic preference for the
 - endo conformation (mirroring the preference of L-Pro).
- ((4R)-4-methyl-D-Proline: The introduction of a methyl group at the C4 position creates a steric clash with the backbone carbonyl if the ring adopts the endo conformation.
 - Stereochemistry: D-Pro has (2R) stereochemistry. The (4R)-methyl group is cis to the C2-carboxylate (both R).
 - The Lock: To minimize steric strain, the (4R)-methyl group prefers the pseudo-equatorial position, which forces the ring into the
 - exo pucker.

Impact: This shift from a flexible/endo-biased state (D-Pro) to a rigid/exo-locked state ((4R)-4-Me-D-Pro) alters the backbone dihedral angles, often tightening

-turns or stabilizing Polyproline II (PPII) helices.

Graphviz Diagram: Conformational Pucker Switch

The following diagram illustrates the mechanistic pathway where the methyl substitution forces the conformational lock.

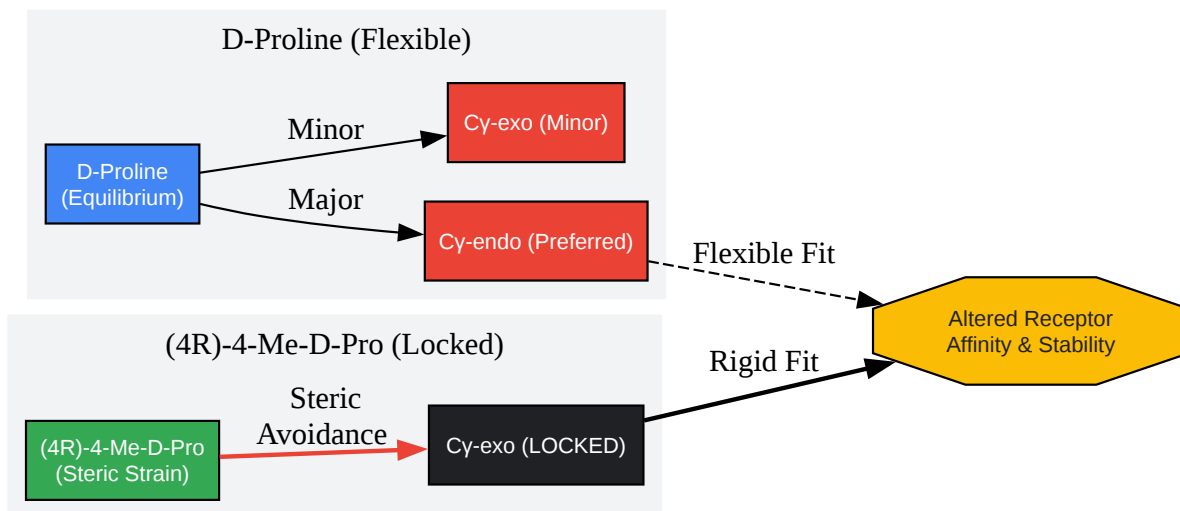

[Click to download full resolution via product page](#)

Caption: The (4R)-methyl group biases the D-Pro ring pucker toward Cy-exo, locking the bioactive conformation.

Comparative Bioactivity Data[2]

The following data summarizes the performance differences in a representative peptidomimetic scenario (e.g., an antimicrobial peptide or GPCR ligand).

Feature	D-Proline Analog	(4R)-4-methyl-D-Pro Analog	Net Effect of Methylation
Ring Pucker	-endo (biased)	-exo (locked)	Conformational Inversion
Lipophilicity ()	Baseline	+0.5 to +0.8 units	Increased Permeability
Proteolytic Stability ()	High (D-amino acid)	Very High (Steric shield)	Extended Half-life
Cis/Trans Amide Ratio	~20% Cis	< 5% Cis (Trans favored)	Backbone Linearization
Receptor Affinity ()	Baseline	Variable (Context dependent)	Potency Switch

Key Interpretation

- Potency: If the receptor pocket requires a sharp turn (compatible with -exo), the methyl analog can increase potency by 10-100x by reducing the entropy cost of binding. If the receptor requires the -endo form, potency will drop drastically.
- Permeability: The added methyl group increases hydrophobicity, aiding in crossing the blood-brain barrier (BBB) or bacterial membranes.

Experimental Validation Protocols

To objectively compare these analogs, you must synthesize the peptide variants and subject them to a rigorous stability and binding workflow.

Synthesis Protocol: Overcoming Steric Hindrance

The secondary amine of 4-methylproline is sterically hindered, making acylation difficult during Solid Phase Peptide Synthesis (SPPS).

Protocol:

- Resin: Use low-loading Rink Amide resin (0.3–0.5 mmol/g) to prevent aggregation.
- Coupling Reagents: Use HATU/HOAt instead of HBTU/HOBt. The aza-benzotriazole (HOAt) is critical for sterically demanding couplings.
- Conditions:
 - Coupling of (4R)-4-Me-D-Pro: Standard double coupling (2 x 45 min).
 - Coupling onto (4R)-4-Me-D-Pro: This is the bottleneck. Use HATU (4 eq), DIEA (8 eq) at 50°C for 2 hours. Double couple.
 - Alternative: Use an acid fluoride activation method if HATU fails.
- Monitoring: Use the Chloranil test (sensitive for secondary amines) rather than the Kaiser test.

Proteolytic Stability Assay

Objective: Quantify the "Steric Shield" effect.

- Preparation: Dissolve peptides (100 μ M) in PBS (pH 7.4).
- Enzyme Challenge: Add Trypsin/Chymotrypsin mix or Human Serum (25% v/v).
- Incubation: Incubate at 37°C with agitation.
- Sampling: Aliquot at t = 0, 1h, 4h, 12h, 24h. Quench immediately with 1% TFA/Acetonitrile.
- Analysis: Analyze via RP-HPLC. Integrate the parent peak area.
- Calculation: Plot

vs. Time to determine

and

.

Decision Workflow for Drug Design

Use this logic flow to determine when to deploy the (4R)-4-methyl-D-Pro analog.

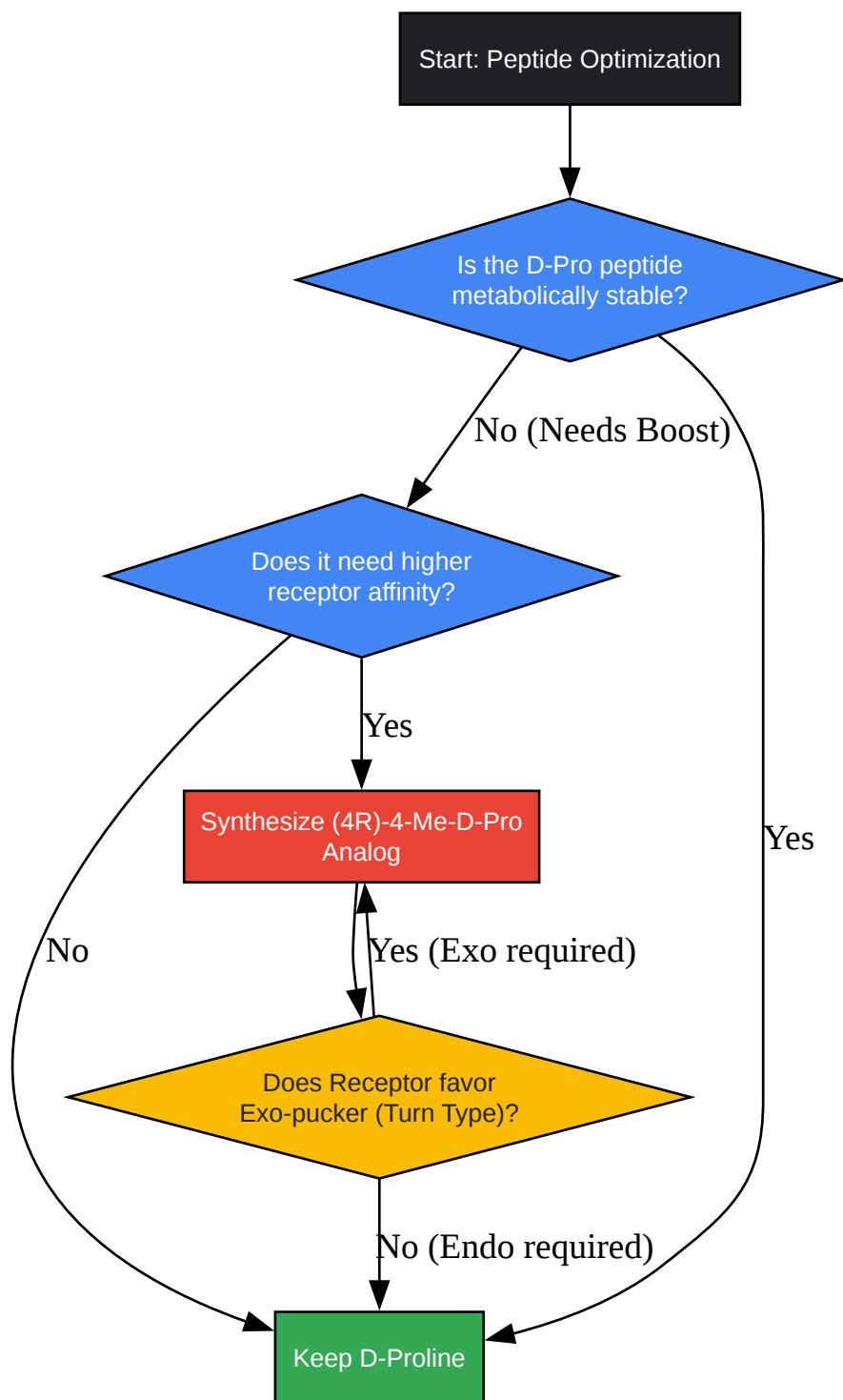

[Click to download full resolution via product page](#)

Caption: Decision matrix for selecting between D-Pro and its 4-methyl analog based on stability and conformational requirements.

References

- Conformational Landscape of Substituted Prolines. Source: National Institutes of Health (NIH) / PubMed Central. Context: Detailed analysis of exo/endo pucker preferences for 4-substituted prolines.
- Analysis of Steric versus Stereoelectronic Effects of 4-Substituted Prolines. Source: ACS Publications / Journal of Organic Chemistry. Context: Defines the rules where 4R-alkyl groups favor specific ring puckers compared to electronegative substituents.
- Difficult Couplings in Solid Phase Peptide Synthesis. Source: PubMed / NIH. Context: Methodologies for overcoming steric hindrance during SPPS of N-methylated and bulky amino acids.
- Bioactivity of D-Amino Acid Peptides. Source: BenchChem Technical Guides.[1] Context: General comparative data on stability and bioactivity of D- vs L-amino acid peptides.[1]

Need Custom Synthesis?

BenchChem offers custom synthesis for rare earth carbides and specific isotopic labeling.

Email: info@benchchem.com or [Request Quote Online](#).

Sources

- [1. pdf.benchchem.com \[pdf.benchchem.com\]](https://pdf.benchchem.com)
- [2. Advances in the stability challenges of bioactive peptides and improvement strategies - PMC \[pmc.ncbi.nlm.nih.gov\]](https://pubmed.ncbi.nlm.nih.gov/)
- To cite this document: BenchChem. [Comparative Bioactivity Guide: D-Pro vs. (4R)-4-methyl-D-Pro Analogs]. BenchChem, [2026]. [Online PDF]. Available at: [\[https://www.benchchem.com/product/b3258923/docs#comparative-bioactivity-guide-d-pro-vs-4r-4-methyl-d-pro-analogs\]](https://www.benchchem.com/product/b3258923/docs#comparative-bioactivity-guide-d-pro-vs-4r-4-methyl-d-pro-analogs)

Disclaimer & Data Validity:

The information provided in this document is for Research Use Only (RUO) and is strictly not intended for diagnostic or therapeutic procedures. While BenchChem strives to provide accurate protocols, we make no warranties, express or implied, regarding the fitness of this product for every specific experimental setup.

Technical Support: The protocols provided are for reference purposes. Unsure if this reagent suits your experiment?

Need Industrial/Bulk Grade? [Request Custom Synthesis Quote](#)

BenchChem

Our mission is to be the trusted global source of essential and advanced chemicals, empowering scientists and researchers to drive progress in science and industry.

Contact

Address: 3281 E Guasti Rd
Ontario, CA 91761, United States
Phone: (601) 213-4426
Email: info@benchchem.com

[Contact our Ph.D. Support Team for a compatibility check](#)