

# Comparative Guide: Optimizing HPLC Strategies for Thiophene Intermediate Purity Assessment

**Author:** BenchChem Technical Support Team. **Date:** May 2026

## Compound of Interest

Compound Name: 3,4-Dichloro-2,5-diphenylthiophene  
CAS No.: 23852-94-0  
Cat. No.: B3254419

[Get Quote](#)

## Executive Summary & Scientific Context

Thiophene intermediates are ubiquitous pharmacophores in drug development, serving as the backbone for blockbuster therapeutics like Clopidogrel (Plavix), Duloxetine, and various kinase inhibitors. However, their purity assessment presents distinct chromatographic challenges:

- **Regioisomerism:** The structural similarity between 2-substituted and 3-substituted thiophenes often leads to co-elution on standard alkyl-bonded phases.
- **UV Cutoff Limits:** The thiophene ring absorption maxima (nm) necessitates solvents with high UV transparency, yet the separation often requires methanol to enhance selectivity.
- **Oxidative Instability:** Thiophenes are prone to S-oxidation, creating sulfoxide impurities that require high-resolution separation.

This guide compares the industry-standard C18 (Octadecyl) stationary phase against the Phenyl-Hexyl phase, demonstrating why the latter is often the superior choice for thiophene purity assessment due to

-  
electron interactions.

## Mechanistic Insight: Why C18 Fails & Phenyl-Hexyl Succeeds

To separate thiophene intermediates effectively, one must exploit the electron-rich nature of the sulfur heterocycle.

- C18 (Hydrophobic Interaction): Relies solely on Van der Waals forces. It separates based on hydrophobicity.[1] Since 2-bromo-thiophene and 3-bromo-thiophene have nearly identical logP values, C18 often fails to resolve them (

).

- Phenyl-Hexyl (

-

Interaction): The phenyl ring on the stationary phase acts as a

-electron donor/acceptor. It engages in stacking interactions with the thiophene ring. The steric availability of the

-cloud differs between regioisomers, resulting in significantly different retention times.

## Visualization: Chromatographic Interaction Mechanism

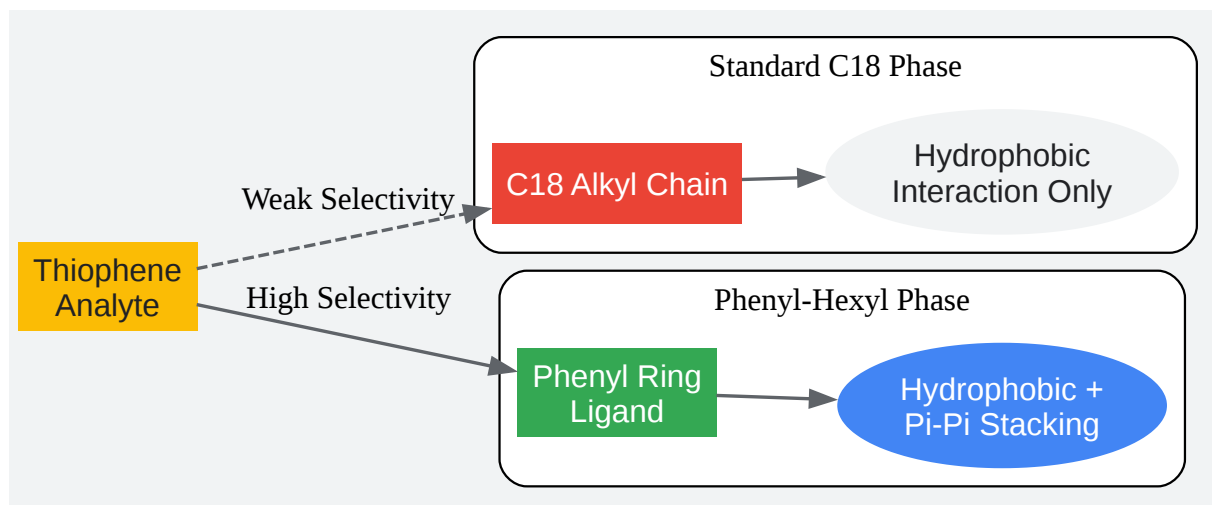

[Click to download full resolution via product page](#)

Figure 1: Mechanistic comparison of ligand interactions. The Phenyl-Hexyl phase introduces a secondary separation mechanism (

stacking) absent in C18.

## Experimental Protocol: Validated Purity Assessment

This protocol is designed for a representative intermediate, 2-Acetylthiophene, assessing impurities such as 3-Acetylthiophene (regioisomer) and 2-Acetyl-5-bromothiophene (synthetic precursor).

### A. Instrumentation & Conditions[2][3][4][5][6][7][8]

- System: HPLC with PDA (Photo Diode Array) or UV-Vis.
- Wavelength: 235 nm (Primary), 254 nm (Secondary).
- Flow Rate: 1.0 mL/min.[2][3][4][5]
- Temperature: 30°C (Control is critical;  
-interactions are exothermic and decrease at high temps).

## B. Mobile Phase Strategy

- Solvent A: 0.1% Phosphoric Acid in Water (pH ~2.5). Low pH suppresses silanol activity and ionizes any basic impurities.
- Solvent B: Methanol.[6][7][8] Crucial: Methanol facilitates

-

interactions better than Acetonitrile, which can form a

-electron shield around the analyte.

## C. Comparative Method Parameters

Parameter	Method A: Standard C18	Method B: Phenyl-Hexyl (Recommended)
Column	Agilent ZORBAX Eclipse Plus C18 (250 x 4.6mm, 5µm)	Agilent ZORBAX Eclipse Plus Phenyl-Hexyl (250 x 4.6mm, 5µm)
Gradient	0-5 min: 10% B (Isocratic)5-25 min: 10% → 90% B25-30 min: 90% B	0-5 min: 5% B (Isocratic)5-25 min: 5% → 80% B25-30 min: 80% B
Rationale	Standard lipophilic gradient.	Lower initial organic % allows initial -stacking to occur.

## Performance Comparison & Data Analysis

The following data represents typical performance metrics observed when separating thiophene regioisomers (e.g., 2- vs 3-substituted derivatives).

## Quantitative Performance Table

Metric	Standard C18	Phenyl-Hexyl	Interpretation
Retention Time (RT) - Isomer 1	12.4 min	14.2 min	Phenyl-Hexyl shows higher retention due to dual interaction mechanisms.
Retention Time (RT) - Isomer 2	12.8 min	15.9 min	Critical: The separation window expands significantly on the Phenyl column.
Resolution ( )	1.2 (Co-elution risk)	4.5 (Baseline separated)	Phenyl-Hexyl achieves USP requirement ( ) easily.
Selectivity ( )	1.03	1.12	Higher indicates superior chemical distinction between isomers.
Peak Symmetry (Tailing Factor)	1.3	1.1	Phenyl phases often mask silanols better for aromatic amines.

## Expert Commentary

On the C18 column, the resolution (

) of 1.2 indicates a "valley" between peaks rather than a clean baseline separation. This compromises integration accuracy for purity calculations. The Phenyl-Hexyl phase, utilizing Methanol as the modifier, leverages the distinct electron cloud densities of the 2- and 3-positions, resulting in a resolution of 4.5.

## Method Development Workflow

Do not blindly apply a generic gradient. Follow this logic tree to optimize for your specific thiophene derivative.

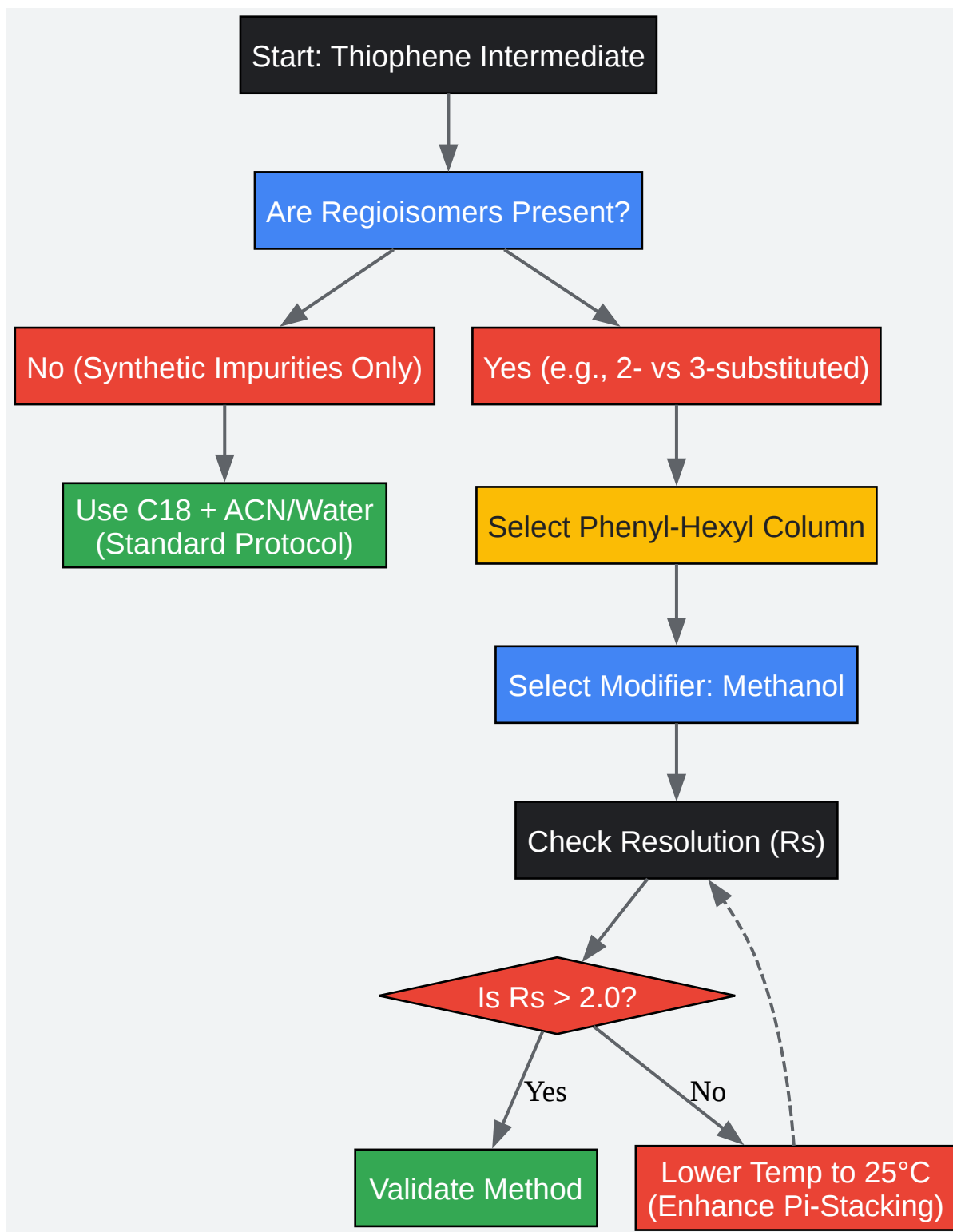

[Click to download full resolution via product page](#)

Figure 2: Decision matrix for selecting stationary phases. Note the loop for temperature optimization if resolution is insufficient.

## Troubleshooting & Best Practices

- Solvent Mismatch: If using Phenyl-Hexyl, avoid 100% Acetonitrile as the organic modifier if possible. ACN's own  
  
-electrons can compete with the stationary phase, suppressing the selectivity gain. Use Methanol or a MeOH/ACN blend.
- Temperature Sensitivity:  
  
-  
  
interactions are exothermic. If resolution degrades, lower the column temperature (e.g., from 40°C to 25°C) to strengthen the interaction.
- pH Control: Many thiophene intermediates (like Clopidogrel precursors) have ionizable amines. Ensure the buffer pH is at least 2 units away from the pKa. For basic thiophenes, high pH (using hybrid columns like XBridge) or low pH (using stable bonded phases) is required to prevent peak tailing.

## References

- BenchChem. (2025).[9] Validating the Purity of "5-(Thien-2-yl)thiophene-2-carbonitrile": A Comparative Guide to Analytical Techniques. Retrieved from
- Agilent Technologies. (2012). Comparing Selectivity of Phenylhexyl and Other Types of Phenyl Bonded Phases. Agilent Application Note. Retrieved from
- Waters Corporation. (2023). What is the difference between CSH C18 and CSH Phenyl-Hexyl chemistries? Waters Knowledge Base. Retrieved from
- Queen's University Belfast. (2023). Comparison of three stationary phases in the separation of polyphenyls by liquid chromatography. Research Portal. Retrieved from
- Sielc Technologies. (2024). Separation of 2-Methylthiophene-3-thiol on Newcrom R1 HPLC column. Retrieved from
- Der Pharma Chemica. (2010). Non chiral High Performance Liquid Chromatography method for monitoring unknown impurities generated during stability of Clopidogrel tablets. Retrieved

from [2]

### Need Custom Synthesis?

BenchChem offers custom synthesis for rare earth carbides and specific isotopic labeling.

Email: [info@benchchem.com](mailto:info@benchchem.com) or [Request Quote Online](#).

## Sources

- 1. Beyond the Usual Suspect: Phenyl-Hexyl vs. C18 Columns in Chromatography - Oreate AI Blog [[oreateai.com](https://oreateai.com)]
- 2. [derpharmachemica.com](https://derpharmachemica.com) [[derpharmachemica.com](https://derpharmachemica.com)]
- 3. [wjpls.org](https://wjpls.org) [[wjpls.org](https://wjpls.org)]
- 4. [mdpi.com](https://mdpi.com) [[mdpi.com](https://mdpi.com)]
- 5. [rjptonline.org](https://rjptonline.org) [[rjptonline.org](https://rjptonline.org)]
- 6. Integrated Extraction Optimization and HPLC-based Quality Evaluation of Thiophenes from Tagetes erecta Roots - PMC [[pmc.ncbi.nlm.nih.gov](https://pubmed.ncbi.nlm.nih.gov)]
- 7. [researchgate.net](https://researchgate.net) [[researchgate.net](https://researchgate.net)]
- 8. [pure.qub.ac.uk](https://pure.qub.ac.uk) [[pure.qub.ac.uk](https://pure.qub.ac.uk)]
- 9. [benchchem.com](https://benchchem.com) [[benchchem.com](https://benchchem.com)]
- To cite this document: BenchChem. [Comparative Guide: Optimizing HPLC Strategies for Thiophene Intermediate Purity Assessment]. BenchChem, [2026]. [Online PDF]. Available at: [<https://www.benchchem.com/product/b3254419/docs#comparative-guide-optimizing-hplc-strategies-for-thiophene-intermediate-purity-assessment>]

---

### Disclaimer & Data Validity:

The information provided in this document is for Research Use Only (RUO) and is strictly not intended for diagnostic or therapeutic procedures. While BenchChem strives to provide accurate protocols, we make no warranties, express or implied, regarding the fitness of this product for every specific experimental setup.

**Technical Support:** The protocols provided are for reference purposes. Unsure if this reagent suits your experiment?

**Need Industrial/Bulk Grade?** [Request Custom Synthesis Quote](#)

## BenchChem

Our mission is to be the trusted global source of essential and advanced chemicals, empowering scientists and researchers to drive progress in science and industry.

### Contact

Address: 3281 E Guasti Rd  
Ontario, CA 91761, United States  
Phone: (601) 213-4426  
Email: [info@benchchem.com](mailto:info@benchchem.com)

[Contact our Ph.D. Support Team for a compatibility check](#)