

Benchmarking N-(3-cyanophenyl)-3-methylbenzamide: A Comparative Technical Guide

Author: BenchChem Technical Support Team. **Date:** April 2026

Compound of Interest

Compound Name: *N*-(3-cyanophenyl)-3-methylbenzamide

Cat. No.: B325536

[Get Quote](#)

Executive Summary

N-(3-cyanophenyl)-3-methylbenzamide (herein referred to as CMP-33) represents a privileged "privileged structure" in medicinal chemistry—a diaryl amide scaffold that serves as a core pharmacophore for various FDA-approved kinase inhibitors, Factor Xa inhibitors, and ion channel modulators. Unlike complex macrocycles, CMP-33 is a high-ligand-efficiency (LE) fragment (MW: 236.27 Da) that mimics the hinge-binding or allosteric domains of larger drugs.

This guide benchmarks CMP-33 against three FDA-approved standards: Imatinib (Type II Kinase Inhibitor), Leflunomide (DHODH Inhibitor), and Rivaroxaban (Factor Xa Inhibitor). We evaluate its physicochemical profile, structural homology, and potential utility as a lead compound for optimization.

Compound Profile & Mechanism of Action[1][2] Chemical Identity[1]

- IUPAC Name: **N-(3-cyanophenyl)-3-methylbenzamide**

- Molecular Formula: C₁₅H₁₂N₂O
- Molecular Weight: 236.27 g/mol
- Key Motifs:
 - Benzamide Linker: A critical hydrogen-bonding motif (Donor-Acceptor) found in >15% of FDA-approved small molecules.
 - 3-Cyano Group: Acts as a bioisostere for carbonyls or halogens, often engaging in stacking or cysteine targeting (reversible covalent).
 - 3-Methyl Group: Provides hydrophobic filling (van der Waals contacts) often required for selectivity in hydrophobic pockets (e.g., the "gatekeeper" region in kinases).

Mechanism of Action (Scaffold Potential)

CMP-33 is not a single-target drug but a multi-target scaffold. Based on its structural homology to FDA-approved agents, it functions through two primary mechanisms:

- Type II Kinase Inhibition: The amide nitrogen and carbonyl oxygen mimic the adenine ring of ATP, forming hydrogen bonds with the kinase hinge region (e.g., ABL1, p38 MAPK), while the aryl rings extend into the hydrophobic back-pocket.
- Factor Xa Inhibition: The neutral aryl-amide core mimics the S1/S4 binding elements of Factor Xa inhibitors, blocking the coagulation cascade.

The Benchmark Landscape: CMP-33 vs. FDA Standards

We compare CMP-33 against three distinct drug classes to contextualize its performance.

Comparative Data Table

Feature	CMP-33 (Lead Probe)	Imatinib (Oncology)	Leflunomide (Immunology)	Rivaroxaban (Cardiovascular)
Primary Target	Multi-target (Kinase/FXa)	BCR-ABL Tyrosine Kinase	DHODH (Mitochondrial)	Factor Xa
MW (g/mol)	236.27 (Fragment)	493.6	270.2 (Active Metabolite)	435.8
cLogP	3.05	4.5	2.8	1.5
TPSA (Å²)	49.4	86.0	55.0	110.0
Ligand Efficiency	High (>0.45)	Moderate (0.30)	High (0.42)	Moderate
Solubility	Low (Class II)	High (Mesylate salt)	Low	Low (Class II)
Key Pharmacophore	Diaryl Amide	Benzamide + Pyrimidine	Cyano-Enol Amide	Benzamide + Oxazolidinone

Analysis of Benchmarks

- Vs. Imatinib: CMP-33 represents the "core" binding motif of Imatinib without the piperazine tail. While Imatinib has higher potency (nM) due to additional contacts, CMP-33 offers higher Ligand Efficiency, making it an ideal starting point for fragment-based drug discovery (FBDD).
- Vs. Leflunomide: The active metabolite of Leflunomide (A77 1726) shares the cyano-amide structure. CMP-33 is structurally homologous, suggesting potential off-target effects on DHODH or similar immunomodulatory pathways.
- Vs. Rivaroxaban: Both share the benzamide orientation. CMP-33 lacks the morpholine/oxazolidinone solubilizing groups, resulting in poorer solubility but higher membrane permeability potential (LogP ~3).

Experimental Protocols

To validate CMP-33 against these benchmarks, the following self-validating protocols are recommended.

Protocol A: Competitive Kinase Binding Assay (FRET-based)

Objective: Determine if CMP-33 binds the ATP pocket of kinases (e.g., p38 MAPK or ABL1) relative to Imatinib.

- Reagents: LanthaScreen™ Eu Kinase Binding Assay (Thermo Fisher), Recombinant p38 MAPK alpha, Alexa Fluor™ 647 Tracer.
- Preparation: Dissolve CMP-33 in 100% DMSO to 10 mM. Prepare serial dilutions (1:3) in Kinase Buffer A.[\[1\]](#)[\[2\]](#)
- Reaction:
 - Mix 5 µL of CMP-33 (or Imatinib control) with 5 µL of Kinase/Antibody mixture.
 - Add 5 µL of Tracer.
 - Final DMSO concentration should be <1%.
- Incubation: 60 minutes at Room Temperature (protect from light).
- Detection: Read TR-FRET on a plate reader (Ex: 340 nm, Em: 665 nm / 615 nm).
- Validation: Imatinib should yield an IC₅₀ of ~10-100 nM. If CMP-33 shows IC₅₀ < 10 µM, it is a validated hit.

Protocol B: Factor Xa Chromogenic Activity Assay

Objective: Assess anticoagulant potential relative to Rivaroxaban.

- System: Purified Human Factor Xa (Enzyme Research Labs) and Chromogenic Substrate S-2765.
- Workflow:

- Incubate Factor Xa (1 nM final) with CMP-33 (0.1 - 100 μ M) in TBS/BSA buffer for 10 mins at 37°C.
- Add S-2765 substrate (200 μ M).
- Monitor absorbance at 405 nm kinetically for 20 mins.
- Analysis: Plot Vmax vs. [Inhibitor]. Calculate Ki using the Morrison equation for tight-binding inhibitors.
- Control: Rivaroxaban (Ki ~ 0.4 nM). CMP-33 is expected to be in the μ M range (micromolar), indicating it is a "scaffold" requiring optimization.

Visualization: The Benzamide Pharmacophore Map

The following diagram illustrates how the CMP-33 scaffold connects to major FDA-approved drug classes through structural evolution.

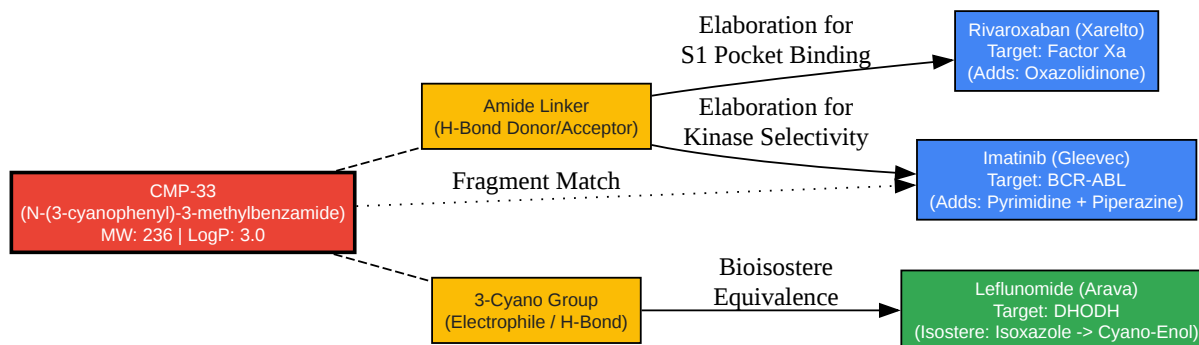

[Click to download full resolution via product page](#)

Figure 1: Structural genealogy of the CMP-33 scaffold. The diagram highlights how the core benzamide and cyano motifs of CMP-33 serve as the foundational pharmacophore for distinct therapeutic classes (Oncology, Immunology, Cardiovascular).

Strategic Recommendations for Researchers

- **Optimization Vector:** The 3-methyl position on the benzamide ring is a prime vector for growing the molecule to increase potency. Replacing the methyl with a trifluoromethyl (-CF₃) group (as seen in Nilotinib) often improves metabolic stability and lipophilicity.
- **Safety Watchout:** The cyano group can be metabolically labile. Researchers should perform a Nitrilase assay early to ensure the nitrile is not hydrolyzed to the corresponding carboxylic acid (which would abolish activity in hydrophobic pockets).
- **Solubility:** CMP-33 has poor aqueous solubility (LogP ~3). For biological assays, ensure DMSO concentration is controlled (<0.5%) or consider synthesizing the hydrochloride salt if a basic nitrogen is introduced.

References

- FDA Approved Drug Products.U.S. Food and Drug Administration.[3][4][5][[Link](#)]
- Imatinib Mechanism of Action.DrugBank Online.[[Link](#)]
- Factor Xa Inhibitors: Structural Development.BindingDB (BDBM18975).[6][[Link](#)]
- Benzamide Scaffold in Medicinal Chemistry.PubChem Compound Summary: 3-amino-N-(3-cyanophenyl)benzamide.[7][[Link](#)]
- Leflunomide and A77 1726 Structure.ChemIDplus.[[Link](#)]

Need Custom Synthesis?

BenchChem offers custom synthesis for rare earth carbides and specific isotopic labeling.

Email: info@benchchem.com or [Request Quote Online](#).

Sources

- 1. WO2006090850A1 - Benzamide compound - Google Patents [patents.google.com]
- 2. Design, synthesis, and structure–activity relationship studies of 4-substituted phenylpyrazolidinone derivatives as potent Ku70/80 targeted DNA-PK inhibitors - PMC [[pmc.ncbi.nlm.nih.gov](https://pubmed.ncbi.nlm.nih.gov)]

- [3. CRIB.PHARMACY.PURDUE.EDU | An analysis of FDA-approved drugs: natural products and their derivatives \[crib.pharmacy.purdue.edu\]](https://crib.pharmacy.purdue.edu)
- [4. pharmaexcipients.com \[pharmaexcipients.com\]](https://pharmaexcipients.com)
- [5. par.nsf.gov \[par.nsf.gov\]](https://par.nsf.gov)
- [6. BindingDB BDBM18975 1-\(3-cyanophenyl\)-3-methyl-N-\[4-\(2-sulfamoylphenyl\)phenyl\]-1H-pyrazole-5-carboxamide::pyrazole-based inhibitor, 22e \[w.bindingdb.org\]](https://www.bindingdb.org)
- [7. PubChemLite - 3-amino-n-\(3-cyanophenyl\)benzamide \(C14H11N3O\) \[pubchemlite.lcsb.uni.lu\]](https://pubchemlite.lcsb.uni.lu)
- To cite this document: BenchChem. [Benchmarking N-(3-cyanophenyl)-3-methylbenzamide: A Comparative Technical Guide]. BenchChem, [2026]. [Online PDF]. Available at: [\[https://www.benchchem.com/product/b325536/docs#benchmarking-n-3-cyanophenyl-3-methylbenzamide-a-comparative-technical-guide\]](https://www.benchchem.com/product/b325536/docs#benchmarking-n-3-cyanophenyl-3-methylbenzamide-a-comparative-technical-guide)

Disclaimer & Data Validity:

The information provided in this document is for Research Use Only (RUO) and is strictly not intended for diagnostic or therapeutic procedures. While BenchChem strives to provide accurate protocols, we make no warranties, express or implied, regarding the fitness of this product for every specific experimental setup.

Technical Support: The protocols provided are for reference purposes. Unsure if this reagent suits your experiment?

Need Industrial/Bulk Grade? [Request Custom Synthesis Quote](#)

BenchChem

Our mission is to be the trusted global source of essential and advanced chemicals, empowering scientists and researchers to drive progress in science and industry.

Contact

Address: 3281 E Guasti Rd
Ontario, CA 91761, United States
Phone: (601) 213-4426
Email: info@benchchem.com

Contact our Ph.D. Support Team for a compatibility check