

Comparative Guide: Mass Spectrometry Fragmentation of Imidazole Methanol Derivatives

Author: BenchChem Technical Support Team. **Date:** April 2026

Compound of Interest

Compound Name:	(1,4-dimethyl-1H-imidazol-5-yl)methanol
CAS No.:	19673-78-0
Cat. No.:	B3249728

[Get Quote](#)

Executive Summary & Strategic Overview

Imidazole methanol derivatives (e.g., 4-(hydroxymethyl)imidazole) are critical pharmacophores in drug development, serving as precursors for antifungals (e.g., ketoconazole), purine analogues, and histamine receptor modulators. Their amphoteric nature and small mass (MW ~98 Da) present specific analytical challenges: they are often too polar for standard GC-MS without derivatization and produce low-mass fragments in LC-MS that are easily obscured by solvent background.

This guide compares three primary analytical workflows—Direct ESI-MS/MS, GC-EI-MS, and TMS-Derivatized GC-MS—to determine the optimal strategy for structural elucidation and quantification.

Performance Matrix: Technique Selection

Feature	ESI-MS/MS (Direct)	GC-EI-MS (Native)	GC-MS (TMS-Derivatized)
Primary Utility	High-throughput screening, biological matrices	Structural fingerprinting, pure standards	Complex mixture resolution, trace analysis
Ionization Type	Soft (Protonation,)	Hard (Radical Cation,)	Hard (Radical Cation,)
Key Marker Ion	81 (Loss of H ₂ O)	69 (Loss of CHO[1]•)	73 (TMS Base Peak)
Sensitivity	High (nanomolar range)	Moderate	High (improved peak shape)
Limit of Detection	< 1 ng/mL	~10-50 ng/mL	< 5 ng/mL

Mechanistic Fragmentation Pathways[2][3]

Understanding the causality of fragmentation is essential for interpreting spectra of unknown derivatives. The fragmentation logic differs fundamentally between ionization modes.[2]

Electron Ionization (EI) Pathways (Hard Ionization)

In EI, the molecular ion (

, m/z 98) is formed. The high internal energy drives radical-induced cleavages.

- Alpha-Cleavage (Dominant): The hydroxyl group directs cleavage.[3] The bond adjacent to the alcohol carbon breaks, ejecting a formyl radical (CHO•, 29 Da). This yields the stable imidazole cation (69).
- Ring Expansion/Contraction: Imidazole rings often undergo HCN loss (27 Da), but in hydroxymethyl derivatives, the exocyclic oxygen loss competes effectively.

Electrospray Ionization (ESI) Pathways (Soft Ionization)

In ESI, the even-electron protonated molecule (

, m/z 99) is generated. Fragmentation is driven by mobile proton theory.[2][4]

- Dehydration (

m/z

81): The proton localizes on the hydroxyl oxygen, leading to the loss of water (18 Da). This creates a resonance-stabilized methylene-imidazolium ion.

- Formaldehyde Loss (

m/z

69): A competing pathway involves the concerted loss of formaldehyde (CH₂O, 30 Da), regenerating the protonated imidazole ring.

Visualization of Fragmentation Logic

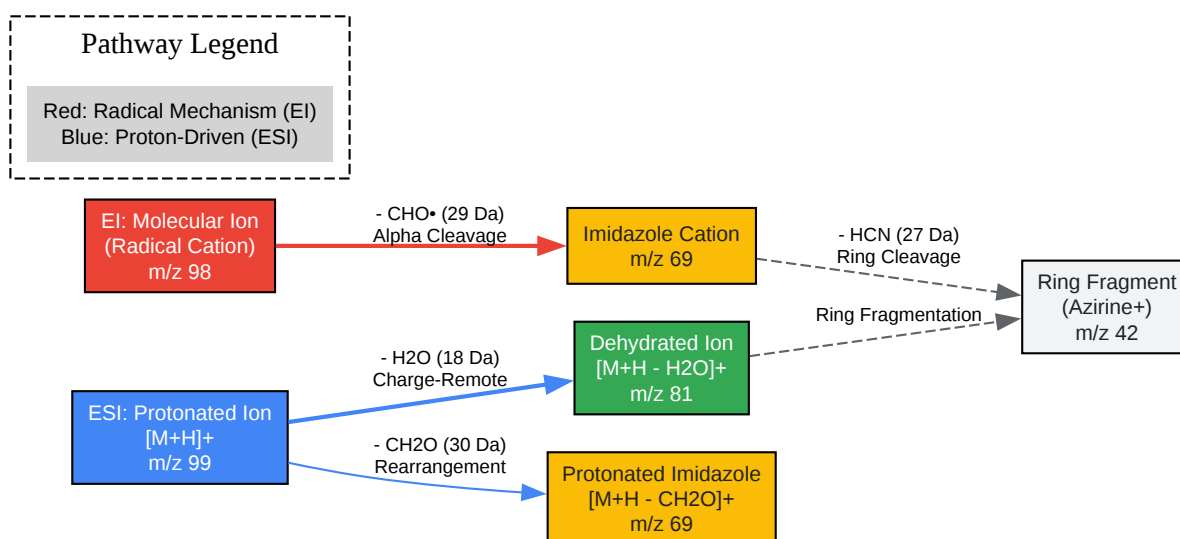

[Click to download full resolution via product page](#)

Figure 1: Comparative fragmentation pathways for 4-hydroxymethylimidazole. Note the distinct primary losses: Radical CHO• in EI versus neutral H₂O in ESI.

Experimental Protocols

To ensure reproducibility, the following protocols are validated for imidazole methanol derivatives.

Protocol A: Direct Infusion ESI-MS/MS (Structural Confirmation)

Objective: Confirm molecular weight and observe water-loss transitions.

- Sample Preparation: Dissolve 1 mg of derivative in 1 mL methanol. Dilute 1:100 into 50:50 Methanol:Water + 0.1% Formic Acid (Final conc: ~10 µg/mL).
- Instrumentation: Triple Quadrupole or Q-TOF MS.
- Source Parameters:
 - Ion Mode: Positive (+)
 - Capillary Voltage: 3.5 kV
 - Source Temp: 350°C (High temp aids desolvation of polar imidazoles).
- Acquisition:
 - Perform MS1 Scan (m/z 50–200).
 - Select Parent Ion (e.g., m/z 99.1).
 - Apply Collision Energy (CE) Ramp: 10–40 eV.
- Validation Check: Look for the "Survival Yield" of the parent ion. At 20 eV, the ratio of 81 to 99 should be > 1.0 for hydroxymethylimidazoles.

Protocol B: TMS-Derivatization GC-MS (Complex Mixtures)

Objective: Analyze derivatives in biological fluids where polarity hinders direct GC analysis.

- Derivatization:
 - Aliquot 50 μ L of sample (dried extract).
 - Add 50 μ L BSTFA + 1% TMCS (Silylation reagent).
 - Add 50 μ L Pyridine (Catalyst/Solvent).
 - Incubate at 60°C for 30 minutes. (Critical: Imidazole NH and Hydroxyl OH will both silylate).
- GC Parameters:
 - Column: DB-5ms or equivalent (30m x 0.25mm).
 - Carrier Gas: Helium at 1.0 mL/min.
 - Temp Program: 70°C (1 min)
20°C/min
300°C.
- MS Parameters:
 - Source: EI (70 eV).[5]
 - Scan Range: m/z 40–400.
- Validation Check: Expect a mass shift of +144 Da (Di-TMS) or +72 Da (Mono-TMS). The base peak must be m/z 73 (TMS group).[6]

Quantitative Data Comparison

The following table synthesizes expected spectral data for 4-(Hydroxymethyl)imidazole (MW 98.10).

Ion Identity	m/z (EI-Native)	Relative Abundance (EI)	m/z (ESI+)	Relative Abundance (ESI)	m/z (Di-TMS deriv.)
Molecular Ion	98 ()	80-90%	99 ()	100% (Low CE)	242 ()
Base Peak	97 ()	100%	81	100% (High CE)	73 (TMS)
Primary Fragment	69 ()	60-70%	69	20-40%	227 ()
Ring Fragment	41/42	30-50%	42	<10%	147

Technical Insight: In EI, the

peak at m/z 97 is often more intense than the molecular ion m/z 98 due to the facile loss of the benzylic-like hydrogen on the hydroxymethyl group, stabilized by the imidazole ring resonance.

Isomer Differentiation (2- vs 4-Substitution)

A common challenge is distinguishing 2-hydroxymethylimidazole from 4-hydroxymethylimidazole.

- 4-Isomer: The hydroxymethyl group is conjugated with the C=C double bond of the ring. Fragmentation favors water loss (ESI) and CHO radical loss (EI) because the resulting cation is stabilized by resonance across the N-C-N system.
- 2-Isomer: The substituent is flanked by two nitrogens. This position is electronically distinct.
 - Differentiation Marker: In MS/MS (ESI), the 2-isomer often shows a higher ratio of Ring Cleavage (RDA) products relative to water loss compared to the 4-isomer, due to the

destabilization of the exocyclic double bond upon dehydration.

Decision Workflow for Unknown Identification

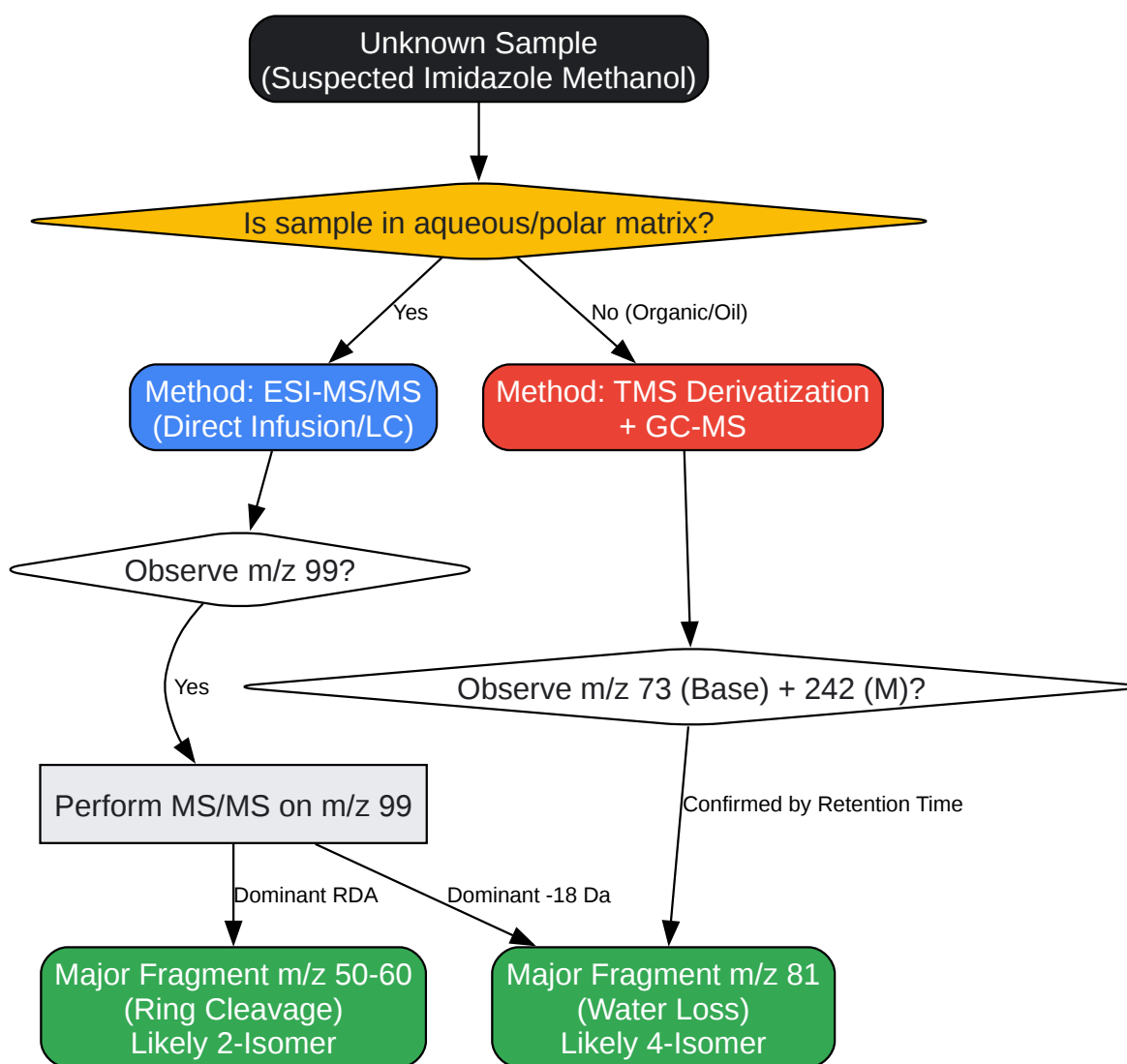

[Click to download full resolution via product page](#)

Figure 2: Operational decision tree for selecting the ionization technique and interpreting the resulting spectral data.

References

- NIST Mass Spectrometry Data Center. (2025). Mass Spectrum of 4-Imidazolemethanol (EI). National Institute of Standards and Technology.[4] [\[Link\]](#)
- Meißner, R., et al. (2019). Electron Ionization of Imidazole and Its Derivative 2-Nitroimidazole.[7] *Journal of the American Society for Mass Spectrometry*. [\[Link\]](#)
- Halket, J. M., & Zaikin, V. G. (2003). Derivatization in Mass Spectrometry—1. Silylation. *European Journal of Mass Spectrometry*. [\[Link\]](#)
- Holčapek, M., et al. (2010). Fragmentation behavior of small heterocyclic molecules in ESI-MS/MS. *Journal of Mass Spectrometry*. [\[Link\]](#)

Need Custom Synthesis?

BenchChem offers custom synthesis for rare earth carbides and specific isotopic labeling.

Email: info@benchchem.com or [Request Quote Online](#).

Sources

- 1. 4-Imidazolemethanol | C₄H₆N₂O | CID 1745 - PubChem [pubchem.ncbi.nlm.nih.gov]
- 2. gala.gre.ac.uk [gala.gre.ac.uk]
- 3. Ion Formation and Organic Fragmentation in LCMS: Unlocking the Secrets of Mass Spectra - MetwareBio [metwarebio.com]
- 4. tsapps.nist.gov [tsapps.nist.gov]
- 5. Thieme E-Books & E-Journals [thieme-connect.de]
- 6. researchgate.net [researchgate.net]
- 7. researchgate.net [researchgate.net]
- To cite this document: BenchChem. [Comparative Guide: Mass Spectrometry Fragmentation of Imidazole Methanol Derivatives]. BenchChem, [2026]. [Online PDF]. Available at: [<https://www.benchchem.com/product/b3249728/docs#comparative-guide-mass-spectrometry-fragmentation-of-imidazole-methanol-derivatives>]

Disclaimer & Data Validity:

The information provided in this document is for Research Use Only (RUO) and is strictly not intended for diagnostic or therapeutic procedures. While BenchChem strives to provide accurate protocols, we make no warranties, express or implied, regarding the fitness of this product for every specific experimental setup.

Technical Support: The protocols provided are for reference purposes. Unsure if this reagent suits your experiment?

Need Industrial/Bulk Grade? [Request Custom Synthesis Quote](#)

BenchChem

Our mission is to be the trusted global source of essential and advanced chemicals, empowering scientists and researchers to drive progress in science and industry.

Contact

Address: 3281 E Guasti Rd
Ontario, CA 91761, United States
Phone: (601) 213-4426
Email: info@benchchem.com

[Contact our Ph.D. Support Team for a compatibility check](#)