

Technical Safety & Handling Guide: 2-Chloroquinolin-6-ol Hydrochloride

Author: BenchChem Technical Support Team. **Date:** May 2026

Compound of Interest

Compound Name:	2-Chloroquinolin-6-ol hydrochloride
CAS No.:	189362-46-7
Cat. No.:	B3248809

[Get Quote](#)

Executive Summary

2-Chloroquinolin-6-ol hydrochloride (Free base CAS: 577967-89-6) is a high-value heterocyclic intermediate primarily utilized in the synthesis of kinase inhibitors, tau-protein PET tracers, and ferroptosis inhibitors. Its dual-functional scaffold—featuring a nucleophile-susceptible chlorine at the C2 position and a modifiable hydroxyl group at C6—makes it a versatile building block in medicinal chemistry.

However, the hydrochloride salt form introduces specific handling challenges distinct from the free base, including increased hygroscopicity, acidity, and potential corrosivity. This guide synthesizes physicochemical data with field-proven protocols to ensure the integrity of the compound and the safety of the researcher.

Physicochemical Profile

The following data distinguishes the commercially available free base from the hydrochloride salt form often generated or utilized in specific synthetic steps.

Property	Free Base (2-Chloroquinolin-6-ol)	Hydrochloride Salt (2-Chloroquinolin-6-ol HCl)
CAS Number	577967-89-6	Not widely listed (Custom/In-situ)
Formula	C ₉ H ₆ ClNO	C ₉ H ₆ ClNO[1] · HCl
Molecular Weight	179.60 g/mol	~216.06 g/mol
Appearance	Yellow to off-white powder	White to pale yellow crystalline solid
Solubility (Water)	Low (Hydrophobic)	Moderate to High (Acidic pH)
Solubility (Organic)	DMSO, DMF, Methanol	DMSO, Methanol (limited in non-polar)
Acidity (pKa)	~8.26 (OH group)	Strongly acidic (HCl dissociation)
Melting Point	192–196 °C	>200 °C (Decomposes)

“

Expert Insight: The hydrochloride salt is significantly more hygroscopic than the free base. Exposure to ambient moisture can lead to clumping and hydrolysis, altering the stoichiometry of sensitive downstream reactions like Buchwald-Hartwig couplings.

Hazard Identification & Toxicology (E-E-A-T)

While specific toxicological data for the HCl salt is limited, a Read-Across assessment based on the quinoline scaffold and hydrochloride moiety dictates the following safety profile.

Core Hazards

- **Skin & Eye Corrosion (H314/H318):** Unlike the irritant free base, the HCl salt releases hydrochloric acid upon contact with moisture (mucous membranes), posing a risk of serious eye damage.
- **Acute Toxicity (Oral):** Quinolines are generally harmful if swallowed (Category 4).
- **Genotoxicity Alert:** The quinoline backbone is structurally related to known mutagens. While 2-substitution often reduces metabolic activation compared to unsubstituted quinoline, this compound should be handled as a suspected mutagen until proven otherwise.

Reactivity Hazards

- **Incompatibility:** Reacts vigorously with strong oxidizing agents and strong bases (releasing heat and neutralizing the salt).
- **Thermal Decomposition:** Emits toxic fumes of Hydrogen Chloride (HCl), Nitrogen Oxides (NO_x), and Carbon Monoxide (CO) upon heating to decomposition.

Technical Handling Protocol

This protocol is designed as a self-validating system: if the material clumps or changes color, the containment or storage conditions have failed.

Storage & Stability

- **Temperature:** 2–8 °C (Refrigerated).
- **Atmosphere:** Store under inert gas (Argon or Nitrogen). The HCl salt is prone to deliquescence.
- **Container:** Amber glass vial with a Teflon-lined cap to prevent light degradation (photo-oxidation of the quinoline ring) and moisture ingress.

Weighing & Dispensing Workflow

The following workflow utilizes a "Static-Free, Moisture-Free" loop to maintain compound integrity.

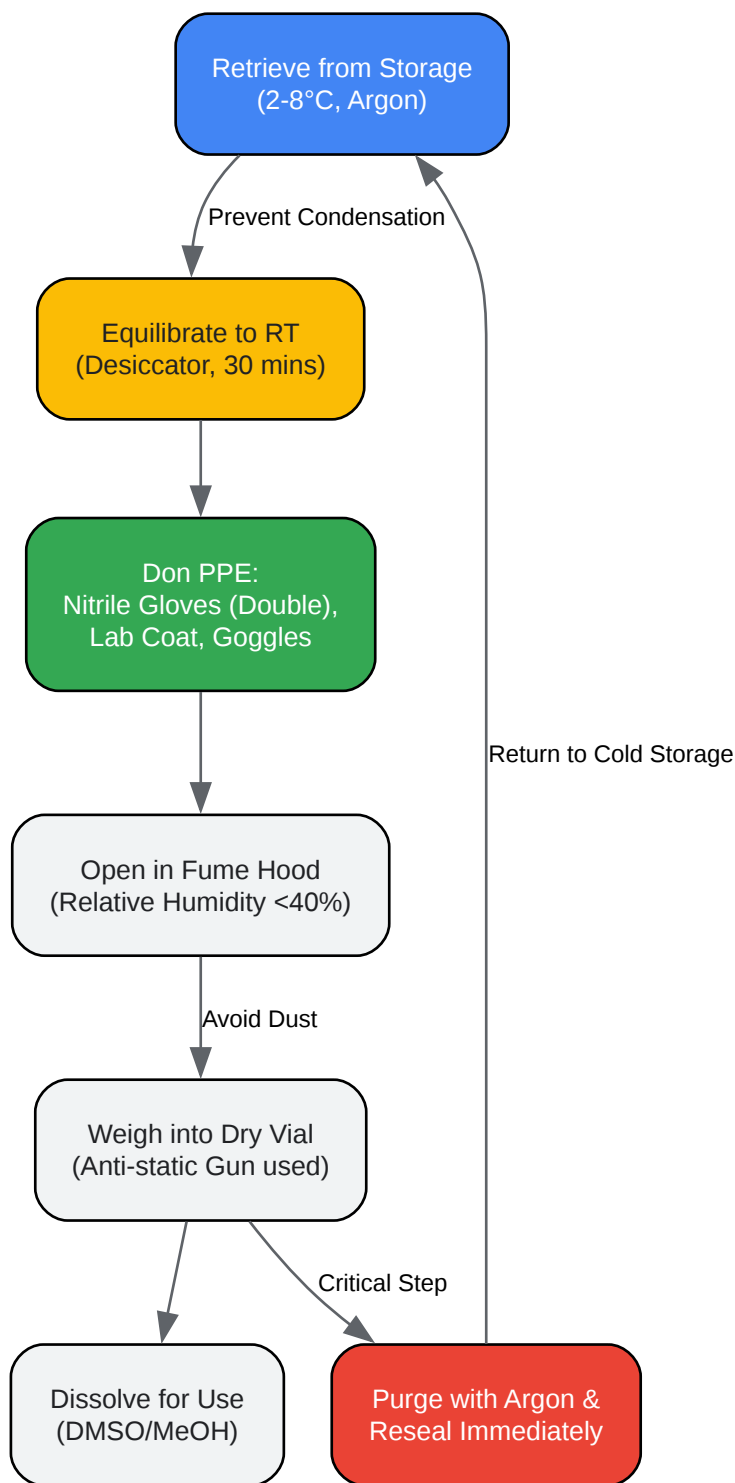

[Click to download full resolution via product page](#)

Figure 1: Safe handling workflow emphasizing moisture control to prevent hydrolysis of the HCl salt.

Solubilization Logic

- Solvent Choice: Use DMSO or DMF for stock solutions. Avoid protic solvents (water/ethanol) if the compound is intended for anhydrous coupling reactions (e.g., Sonogashira), as the HCl salt will retain moisture.
- Neutralization: If the free base is required in situ, add 1.0–1.1 equivalents of a tertiary amine (e.g., Triethylamine or DIPEA) to the solution.

Strategic Applications (Mechanism of Action)

Understanding the reactivity profile helps researchers anticipate by-products and safety risks during synthesis.

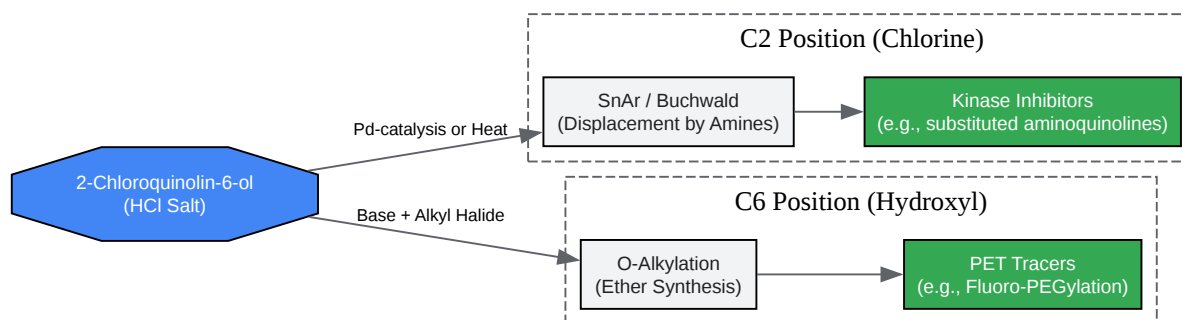

[Click to download full resolution via product page](#)

Figure 2: Dual-reactivity pathways. The C2-Chlorine allows for amine coupling (common in drug discovery), while the C6-Hydroxyl allows for solubility modulation or linker attachment.

Emergency Response & Waste Disposal

Spill Cleanup

- Isolate: Evacuate the immediate area if dust is generated.
- PPE: Wear a NIOSH-approved N95/P100 respirator, safety goggles, and nitrile gloves.

- Neutralize: Cover the spill with Sodium Bicarbonate (NaHCO_3) or a spill pillow to neutralize the acidity of the HCl salt.
- Collect: Sweep up carefully (avoiding dust) into a biohazard/chemical waste bag.
- Clean: Wipe the surface with water followed by ethanol.

First Aid

- Eye Contact: CRITICAL. Rinse immediately with water for 15+ minutes. The HCl salt causes rapid pH drop in the eye; immediate irrigation is vital to prevent corneal opacity.
- Skin Contact: Wash with soap and water. If irritation persists (redness/burning), seek medical attention.

Disposal

- Classification: Hazardous Chemical Waste (Toxic, Irritant).
- Stream: Segregate into Halogenated Organic Waste containers due to the chlorine content.
- Do Not: Do not dispose of down the drain; quinolines are toxic to aquatic life.

References

- National Center for Biotechnology Information (2025). PubChem Compound Summary for CID 22132577, 2-Chloroquinolin-6-ol. Retrieved from [[Link](#)]
- Vermeulen, K., et al. (2017). Discovery of N-(4-[^{18}F]fluoro-5-methylpyridin-2-yl)isoquinolin-6-amine (JNJ-64326067), a new promising tau positron emission tomography (PET) imaging tracer.[2] (Contextualizing the use of 2-chloroquinolin-6-ol as a precursor). Retrieved from [[Link](#)]

Need Custom Synthesis?

BenchChem offers custom synthesis for rare earth carbides and specific isotopic labeling.

Email: info@benchchem.com or [Request Quote Online](#).

Sources

- [1. echemi.com \[echemi.com\]](#)
- [2. researchgate.net \[researchgate.net\]](#)
- To cite this document: BenchChem. [Technical Safety & Handling Guide: 2-Chloroquinolin-6-ol Hydrochloride]. BenchChem, [2026]. [Online PDF]. Available at: [\[https://www.benchchem.com/product/b3248809/docs#technical-safety-handling-guide-2-chloroquinolin-6-ol-hydrochloride\]](https://www.benchchem.com/product/b3248809/docs#technical-safety-handling-guide-2-chloroquinolin-6-ol-hydrochloride)

Disclaimer & Data Validity:

The information provided in this document is for Research Use Only (RUO) and is strictly not intended for diagnostic or therapeutic procedures. While BenchChem strives to provide accurate protocols, we make no warranties, express or implied, regarding the fitness of this product for every specific experimental setup.

Technical Support: The protocols provided are for reference purposes. Unsure if this reagent suits your experiment?

Need Industrial/Bulk Grade? [Request Custom Synthesis Quote](#)

BenchChem

Our mission is to be the trusted global source of essential and advanced chemicals, empowering scientists and researchers to drive progress in science and industry.

Contact

Address: 3281 E Guasti Rd
Ontario, CA 91761, United States
Phone: (601) 213-4426
Email: info@benchchem.com

[Contact our Ph.D. Support Team for a compatibility check](#)

