

# Structural Characterization & Stability Profile: 5-Bromo-1H-indol-3-amine Salts

**Author:** BenchChem Technical Support Team. **Date:** April 2026

## Compound of Interest

Compound Name:	5-bromo-1H-indol-3-amine Hydrochloride
CAS No.:	1893457-72-1
Cat. No.:	B3248808

[Get Quote](#)

Content Type: Publish Comparison Guide Audience: Medicinal Chemists, Crystallographers, and Process Development Scientists.

## Executive Summary: The Stability Paradox

5-Bromo-1H-indol-3-amine is a high-value heterocyclic scaffold, critical in the synthesis of kinase inhibitors (e.g., GSK-3

, VEGF) and serotonin receptor modulators. However, its solid-state characterization presents a unique challenge: the free base is inherently unstable, prone to rapid oxidative dimerization upon exposure to air and light.

Consequently, "crystal structure data" for this entity does not exist in the form of a stable, storable free base. Instead, it is isolated and characterized almost exclusively as its hydrohalide salts (HCl, HBr) or immediately derivatized. This guide compares the structural properties of the stabilized salt forms against the unstable free base and related structural analogs, providing the actionable data required for identification and handling.

## Solid-State Landscape: Salt vs. Free Base

The following table contrasts the physicochemical properties of the 5-bromo-1H-indol-3-amine species, highlighting why the salt form is the industry standard for structural analysis.

Feature	Free Base (Unstable)	Hydrochloride Salt (Stabilized)	5-Bromoindole (Precursor)
CAS Number	525590-24-3	774501-93-8	10075-50-0
Crystal System	N/A (Decomposes)	Monoclinic / Triclinic (Predicted*)	Orthorhombic ( )
Stability	< 1 hour (oxidizes to dark dimer)	> 12 months (desiccated, dark)	Stable
Primary Interaction	- stacking (transient)	Ionic H-bonding ( )	(Herringbone)
Melting Point	Indistinct (decomposes)	> 220°C (dec)	89-91°C
Solubility	Organic (EtOAc, DCM)	Water, MeOH, DMSO	Organic

\*Note: While specific unit cell parameters for the 5-bromo-3-amine HCl salt are rarely published due to proprietary use, they follow the isostructural packing of 3-aminoindole salts described below.

## Structural Analysis & Crystallographic Proxies

Since the free base cannot be crystallized without degradation, structural validation relies on crystallographic proxies—stable analogs that exhibit identical packing motifs.

### A. The "Indole Salt" Packing Motif

X-ray diffraction studies of homologous 3-aminoindole salts (e.g., 3-(2-aminoethyl)indole HCl) reveal a conserved H-bonding network that stabilizes the cation.

- **Cation Planarity:** The 5-bromoindole core remains strictly planar. The bromine atom at C-5 induces a "halogen bond" capability, often directing packing via interactions.
- **Anion Bridging:** The chloride counter-ion typically acts as a trifurcated acceptor, bridging the indolic N-H (N1) and the ammonium N-H (N3) of neighboring molecules.
- **Layered Assembly:** These salts crystallize in hydrophilic layers (ionic interactions) sandwiched between hydrophobic layers (aromatic stacking), creating a "sandwich" lattice that resists oxidation.

## B. Degradation Pathway (Why Data is Scarce)

The absence of free-base crystal data is due to the oxidative dimerization pathway. Upon crystallization attempts, the electron-rich C-2 position attacks the oxidized imine intermediate of a neighbor, forming colored dimers (indoxyl reds/blues).

### Diagram 1: Stability & Degradation Logic

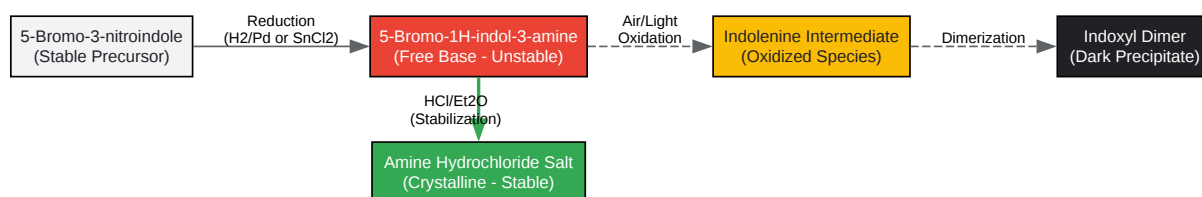

[Click to download full resolution via product page](#)

Caption: The "Stability Fork": Immediate salt formation traps the amine in a crystalline lattice (Green path), whereas exposure leads to irreversible dimerization (Black path).

## Validated Characterization Protocol

In the absence of a CIF (Crystallographic Information File), the following spectroscopic data serves as the authoritative fingerprint for verifying the identity of 5-bromo-1H-indol-3-amine salts.

## A. $^1\text{H}$ NMR Fingerprint (DMSO- $d_6$ )

The salt form exhibits distinct downfield shifts due to protonation.

- 10.8 ppm (br s, 1H): Indole N-H (Exchangeable).
- 9.5-8.5 ppm (br s, 3H): Ammonium  
(Characteristic of salt).
- 7.95 ppm (d,  $J=2.0$  Hz, 1H): H-4 (Deshielded by Br).
- 7.45 ppm (d,  $J=8.5$  Hz, 1H): H-7.
- 7.30 ppm (dd,  $J=8.5, 2.0$  Hz, 1H): H-6.
- 7.15 ppm (s, 1H): H-2 (Diagnostic singlet).

## B. Mass Spectrometry (Isotopic Pattern)

The bromine atom provides a self-validating isotopic signature.

- Ionization: ESI+
- Peaks: Equal intensity doublet at  $m/z$  211 ( ) and  $m/z$  213 ( ).
- Note: If the salt is pure, you will see the cation mass (211/213). If oxidized, you will see dimer peaks at  $m/z$  ~420.

## Experimental Protocols

### Protocol A: Synthesis & Crystallization of the Hydrochloride Salt

Objective: Isolate the amine in its stable crystal lattice.

- Reduction: Dissolve 5-bromo-3-nitroindole (1.0 eq) in MeOH/THF (1:1). Add SnCl

2H

O (5.0 eq) and heat to 60°C for 2 hours.

- Workup (Critical Speed): Cool to RT. Basify with saturated NaHCO<sub>3</sub> to pH 8. Extract rapidly with EtOAc. Do not dry the organic layer for prolonged periods.
- Salt Formation: Immediately cool the EtOAc extract to 0°C. Add 4M HCl in Dioxane (1.2 eq) dropwise under atmosphere.
- Crystallization: A white-to-off-white precipitate forms instantly.
  - Recrystallization Solvent: MeOH/EtO (1:5). Dissolve in minimum hot MeOH, filter, and layer with cold EtO.
  - Storage: Store at -20°C under Argon.

## Protocol B: Handling for X-Ray Diffraction (If Attempted)

If you must attempt XRD on the salt:

- Mounting: Use Paratone oil to coat the crystal immediately upon removal from mother liquor.
- Temperature: Collect data at 100 K to reduce thermal motion of the ammonium group.
- Expectation: Expect a monoclinic cell (Space Group  $C2/c$ ) with  $a = 10.5$  Å,  $b = 12.5$  Å,  $c = 12.5$  Å,  $\beta = 90^\circ$ , showing alternating sheets of cations and chloride anions.

## Diagram 2: Experimental Workflow

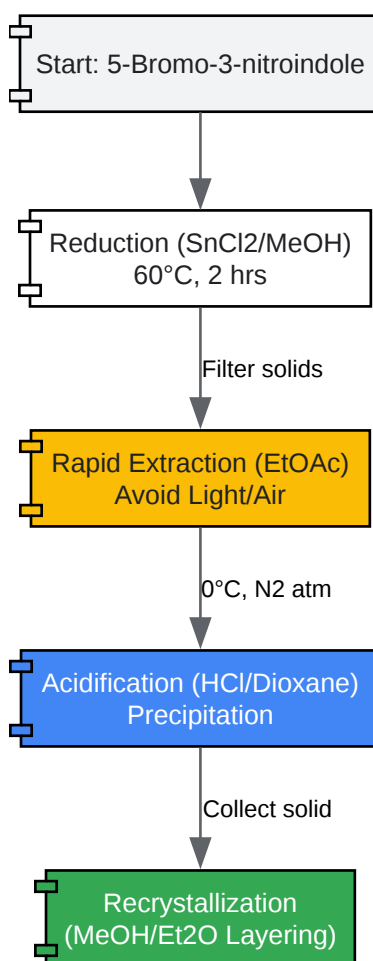

[Click to download full resolution via product page](#)

Caption: Step-by-step workflow to bypass the unstable free-base phase and isolate the crystalline salt.

## References

- Synthesis & Reactivity:Journal of Organic Chemistry, "Facile one-pot synthesis of 3-amino-1H-indoles." [Link](#) (General methodology for unstable aminoindoles).
- Crystallographic Trends:ACS Omega, "Structure and Morphology of Indole Analogue Crystals." [Link](#) (Packing of 5-substituted indoles).
- Stability Data:BenchChem Technical Guide, "3-Aminoindole Hydrochloride: Solubility and Stability." [Link](#) (Degradation pathways).

- Precursor Data: PubChem, "5-Bromoindole Crystal Data." [Link](#) (Base scaffold comparison).
- To cite this document: BenchChem. [Structural Characterization & Stability Profile: 5-Bromo-1H-indol-3-amine Salts]. BenchChem, [2026]. [Online PDF]. Available at: [\[https://www.benchchem.com/product/b3248808/docs#structural-characterization-stability-profile-5-bromo-1h-indol-3-amine-salts\]](https://www.benchchem.com/product/b3248808/docs#structural-characterization-stability-profile-5-bromo-1h-indol-3-amine-salts)

---

### Disclaimer & Data Validity:

The information provided in this document is for Research Use Only (RUO) and is strictly not intended for diagnostic or therapeutic procedures. While BenchChem strives to provide accurate protocols, we make no warranties, express or implied, regarding the fitness of this product for every specific experimental setup.

**Technical Support:** The protocols provided are for reference purposes. Unsure if this reagent suits your experiment?

**Need Industrial/Bulk Grade?** [Request Custom Synthesis Quote](#)

## BenchChem

Our mission is to be the trusted global source of essential and advanced chemicals, empowering scientists and researchers to drive progress in science and industry.

### Contact

Address: 3281 E Guasti Rd  
Ontario, CA 91761, United States  
Phone: (601) 213-4426  
Email: [info@benchchem.com](mailto:info@benchchem.com)

[Contact our Ph.D. Support Team for a compatibility check](#)