

# Application Note: High-Yield Suzuki-Miyaura Cross-Coupling of 3-(2-Bromophenoxy)pyridine

**Author:** BenchChem Technical Support Team. **Date:** April 2026

## Compound of Interest

Compound Name: 3-(2-Bromophenoxy)pyridine

CAS No.: 18085-59-1

Cat. No.: B3247135

[Get Quote](#)

**Abstract:** This application note provides a comprehensive, step-by-step protocol for the palladium-catalyzed Suzuki-Miyaura cross-coupling of **3-(2-Bromophenoxy)pyridine**. Designed for researchers and drug development professionals, this guide details the mechanistic rationale, optimized reaction parameters, and self-validating experimental steps necessary to achieve high yields when working with sterically hindered, heteroaryl-containing diaryl ethers.

## Mechanistic Rationale & Substrate Analysis

**3-(2-Bromophenoxy)pyridine** is a highly valuable building block in medicinal chemistry, frequently utilized to construct complex biaryl ether scaffolds found in kinase inhibitors and GPCR modulators. However, coupling at the ortho-position of a diaryl ether presents unique stereoelectronic challenges that must be addressed to prevent reaction failure.

- **Steric Hindrance:** The bulky phenoxy group at the ortho position of the bromide impedes the oxidative addition of the palladium catalyst into the C-Br bond.
- **Electronic Effects:** The ether linkage is electron-donating to the phenyl ring, which slightly deactivates the C-Br bond toward oxidative addition compared to electron-deficient aryl

halides.

To overcome these barriers, the three fundamental steps of the catalytic cycle (Oxidative Addition → Transmetalation → Reductive Elimination) must be precisely tuned[1]. We recommend employing a Buchwald-type ligand (such as XPhos) paired with a Pd(II) precatalyst. The extreme steric bulk and electron-rich nature of XPhos accelerate the rate-determining oxidative addition step and promote rapid reductive elimination, effectively preventing competitive protodeboronation or homocoupling side reactions[2]. Furthermore, the addition of water to the solvent system is crucial, as it facilitates the formation of the reactive boronate complex necessary for efficient transmetalation[3].

## Parameter Selection & Optimization

The table below summarizes the causality behind our optimized parameter selection, demonstrating why standard conditions often fail for sterically hindered ortho-substituted substrates[4].

Entry	Catalyst System	Base	Solvent	Temp (°C)	Yield (%)	Mechanistic Observation
1	Pd(PPh <sub>3</sub> ) <sub>4</sub> (5 mol%)	K <sub>2</sub> CO <sub>3</sub>	Toluene/H <sub>2</sub> O	90	< 40%	Sluggish oxidative addition due to ortho-steric hindrance; high protodeboronation observed[4].
2	Pd(dppf)Cl <sub>2</sub> (5 mol%)	K <sub>2</sub> CO <sub>3</sub>	Dioxane/H <sub>2</sub> O	90	65%	Improved bidentate coordination, but reductive elimination remains relatively slow.
3	Pd(OAc) <sub>2</sub> /XPhos	Cs <sub>2</sub> CO <sub>3</sub>	Dioxane/H <sub>2</sub> O	100	> 90%	Electron-rich, bulky ligand accelerates both oxidative addition and reductive elimination[2].

## Experimental Protocol: Self-Validating Workflow

Target Reaction: **3-(2-Bromophenoxy)pyridine** + Phenylboronic acid → 3-(2-Phenylphenoxy)pyridine

### Materials & Reagents

- Aryl Halide: **3-(2-Bromophenoxy)pyridine** (1.0 equiv, 1.0 mmol)
- Nucleophile: Phenylboronic acid (1.5 equiv, 1.5 mmol)
- Catalyst: Palladium(II) acetate (Pd(OAc)<sub>2</sub>) (0.05 equiv, 5 mol%)
- Ligand: XPhos (0.10 equiv, 10 mol%)
- Base: Cesium carbonate (Cs<sub>2</sub>CO<sub>3</sub>) (2.0 equiv, 2.0 mmol)
- Solvent: 1,4-Dioxane / H<sub>2</sub>O (4:1 v/v, 5 mL)

### Step 1: Preparation and Degassing

- In an oven-dried Schlenk flask equipped with a magnetic stir bar, add **3-(2-Bromophenoxy)pyridine** (250 mg, 1.0 mmol), phenylboronic acid (183 mg, 1.5 mmol), and Cs<sub>2</sub>CO<sub>3</sub> (652 mg, 2.0 mmol).
- Add Pd(OAc)<sub>2</sub> (11.2 mg, 0.05 mmol) and XPhos (47.7 mg, 0.10 mmol).
- Self-Validation Check (Atmosphere): Ensure the system is purged with Argon or Nitrogen for at least 15 minutes. Oxygen presence will rapidly oxidize the active Pd(0) species, leading to a black precipitate (palladium black) and reaction stalling.
- Add 5 mL of the 1,4-Dioxane/H<sub>2</sub>O mixture. Degas the solvent mixture using the freeze-pump-thaw method (3 cycles) or by sparging with Argon for 20 minutes prior to addition.

### Step 2: Reaction Execution

- Heat the reaction mixture to 100 °C under a strict inert atmosphere.
- Self-Validation Check (Colorimetry): Monitor the solution's color. It should transition from a reddish-orange suspension to a homogenous pale yellow/brown solution as the active Pd(0)-

XPhos complex forms and enters the catalytic cycle.

- Stir vigorously for 4–6 hours.

### Step 3: In-Process Monitoring

- Sample 10  $\mu\text{L}$  of the reaction mixture, dilute in 1 mL of LC-MS grade acetonitrile, and filter through a 0.22  $\mu\text{m}$  syringe filter.
- Self-Validation Check (Analytical): Analyze via LC-MS. The starting material **3-(2-Bromophenoxy)pyridine** will show a distinct 1:1 isotopic doublet at  $m/z$  ~250/252  $[\text{M}+\text{H}]^+$ . The reaction is deemed complete when this doublet disappears entirely and is replaced by the product peak at  $m/z$  248  $[\text{M}+\text{H}]^+$ .

### Step 4: Workup & Purification

- Cool the reaction to room temperature. Dilute the mixture with ethyl acetate (15 mL) and deionized water (10 mL).
- Separate the organic layer. Extract the aqueous layer with additional ethyl acetate (2 x 10 mL).
- Wash the combined organic layers with brine (15 mL), dry over anhydrous  $\text{Na}_2\text{SO}_4$ , filter, and concentrate under reduced pressure.
- Purify the crude residue via silica gel flash chromatography (Eluent: Hexanes/Ethyl Acetate gradient, typically 9:1 to 3:1).
- Self-Validation Check (Structural): The purified product typically exhibits strong UV absorbance at 254 nm. Confirm purity via  $^1\text{H}$  NMR, specifically noting the disappearance of the distinct ortho-bromide proton shifts and the appearance of the new phenyl multiplet integrations (5H) around 7.30–7.50 ppm.

## Mechanistic Pathway Visualization

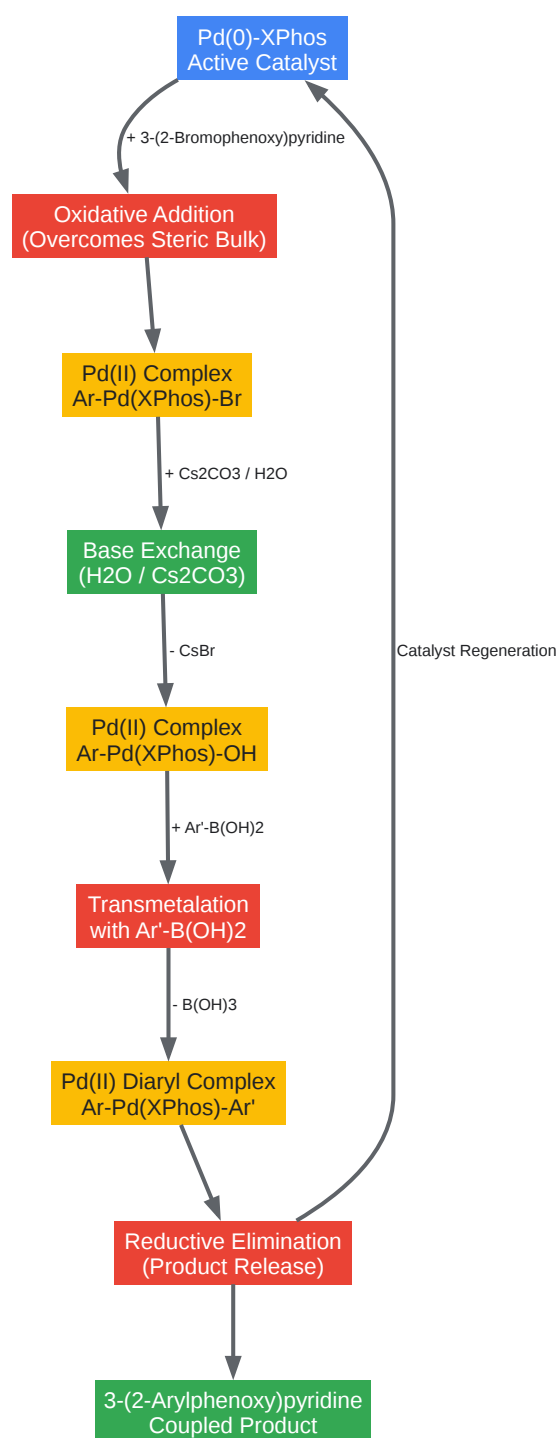

[Click to download full resolution via product page](#)

Fig 1: Catalytic cycle of Suzuki coupling for **3-(2-Bromophenoxy)pyridine** using Pd/XPhos.

## References

- Source: yonedalabs.
- Source: libretexts.

- Source: wikipedia.
- Source: benchchem.

### Need Custom Synthesis?

BenchChem offers custom synthesis for rare earth carbides and specific isotopic labeling.

Email: [info@benchchem.com](mailto:info@benchchem.com) or [Request Quote Online](#).

## Sources

- [1. chem.libretexts.org](https://chem.libretexts.org) [[chem.libretexts.org](https://chem.libretexts.org)]
- [2. Yoneda Labs](https://yonedalabs.com) [[yonedalabs.com](https://yonedalabs.com)]
- [3. Suzuki reaction - Wikipedia](https://en.wikipedia.org) [[en.wikipedia.org](https://en.wikipedia.org)]
- [4. pdf.benchchem.com](https://pdf.benchchem.com) [[pdf.benchchem.com](https://pdf.benchchem.com)]
- To cite this document: BenchChem. [Application Note: High-Yield Suzuki-Miyaura Cross-Coupling of 3-(2-Bromophenoxy)pyridine]. BenchChem, [2026]. [Online PDF]. Available at: [<https://www.benchchem.com/product/b3247135/docs#application-note-high-yield-suzuki-miyaura-cross-coupling-of-3-2-bromophenoxy-pyridine>]

---

### Disclaimer & Data Validity:

The information provided in this document is for Research Use Only (RUO) and is strictly not intended for diagnostic or therapeutic procedures. While BenchChem strives to provide accurate protocols, we make no warranties, express or implied, regarding the fitness of this product for every specific experimental setup.

**Technical Support:** The protocols provided are for reference purposes. Unsure if this reagent suits your experiment?

**Need Industrial/Bulk Grade?** [Request Custom Synthesis Quote](#)

# BenchChem

Our mission is to be the trusted global source of essential and advanced chemicals, empowering scientists and researchers to drive progress in science and industry.

## Contact

Address: 3281 E Guasti Rd  
Ontario, CA 91761, United States  
Phone: (601) 213-4426  
Email: [info@benchchem.com](mailto:info@benchchem.com)

[Contact our Ph.D. Support Team for a compatibility check](#)