

Technical Guide: Structural Elucidation of 3-(2,2-Difluoroethyl)azetidine

Author: BenchChem Technical Support Team. **Date:** May 2026

Compound of Interest

Compound Name: 3-(2,2-Difluoroethyl)azetidine

CAS No.: 1785540-77-3

Cat. No.: B3246534

[Get Quote](#)

Executive Summary

3-(2,2-Difluoroethyl)azetidine (CAS: 121-13-X analog) represents a strategic fluorinated building block in medicinal chemistry. The incorporation of the difluoroethyl group modulates lipophilicity (

) and metabolic stability (blocking metabolic soft spots) while the azetidine ring offers a rigid, sp^3 -rich scaffold that reduces molecular planarity—a key factor in improving clinical success rates.

This guide provides a definitive, self-validating protocol for the structural elucidation of this molecule. It moves beyond basic spectral assignment to address the specific challenges posed by the azetidine ring strain and the complex spin systems introduced by the geminal difluoro moiety.

Part 1: Chemical Context & Synthesis Verification

Before initiating spectral analysis, the origin of the sample must be contextualized to anticipate specific impurities.

Synthetic Origins & Impurity Profiling

The structural integrity of the target depends heavily on its synthetic route. Two common pathways exist, each carrying distinct impurity risks:

Route	Precursors	Key Impurities	Analytical Risk
A	1-Benzhydrylazetid- 3-one + Difluoroethyl Wittig/Horner reagents	Triphenylphosphine oxide, Ring-opened byproducts	NMR required
B	Cross-coupling of 3- Iodoazetidine (N- protected) + Difluoroethyl zinc	Homocoupled dimers, De-iodinated azetidine	HRMS identification

Directive: Ensure the sample is free of paramagnetic impurities (e.g., metal catalysts from Route B) which can broaden NMR lines and obscure the fine splitting of fluorine couplings.

Part 2: Mass Spectrometry (HRMS)

High-Resolution Mass Spectrometry (HRMS) is the first gate of validation. It confirms the molecular formula and provides fragmentation data that supports the presence of the difluoroethyl chain.

Exact Mass Calculation

- Formula:
- Molecular Weight:
- Exact Mass ():

Fragmentation Logic (ESI-MS/MS)

The fragmentation pattern of azetidines is dominated by ring strain release.

- Primary Loss: Cleavage of the difluoroethyl side chain.
 - Loss of ().
 - Loss of ().
- Ring Opening: Retro-[2+2] cycloaddition-type fragmentation is common in strained rings, often yielding ethylene () fragments, though less prominent in substituted azetidines compared to -lactams.

Part 3: NMR Spectroscopy – The Core Elucidation

This is the most critical section. The molecule contains three distinct NMR-active nuclei (, ,) that create a complex coupled system.

NMR: The Anchor Point

Start here. The fluorine signal is distinct and free from solvent overlap.

- Chemical Shift:
to
(typical for terminal
).

- Splitting Pattern: Doublet of triplets (dt).
 - Coupling 1 (Geminal):
 - . This large coupling is diagnostic of the proton directly attached to the group.
 - Coupling 2 (Vicinal):
 - . Coupling to the adjacent methylene () protons.

NMR Interpretation

The proton spectrum will exhibit second-order effects due to the azetidine ring puckering.

Solvent Recommendation:

for resolution;

if the sample is a salt (e.g., HCl salt). Note: Chemical shifts below assume the free base in

.

Position	Proton Type	Approx. Shift ()	Multiplicity & Coupling Logic
Side Chain			tt (Triplet of Triplets). Large () and smaller ().
Ring			m (Multiplet). Complex due to ring puckering and geminal/vicinal coupling within the ring.
Side Chain			tdd (Triplet of Doublets of Doublets). Coupled to (), (), and Ring H3.
Ring			m (Multiplet). The "hub" proton. Coupled to C2/C4 protons and the side chain methylene.

NMR & C-F Coupling

Carbon NMR provides the definitive proof of the carbon skeleton's connectivity to fluorine.

- ():
. Triplet ().
- ():
. Triplet ().
- :
. Triplet (small often , may appear as broad singlet).
- :
. Usually a singlet (too far for significant F coupling).

Part 4: Structural Validation Workflow (Visualization)

The following diagrams illustrate the logical flow of elucidation and the specific 2D NMR correlations required to rule out isomers (specifically the N-substituted isomer).

Elucidation Logic Flow

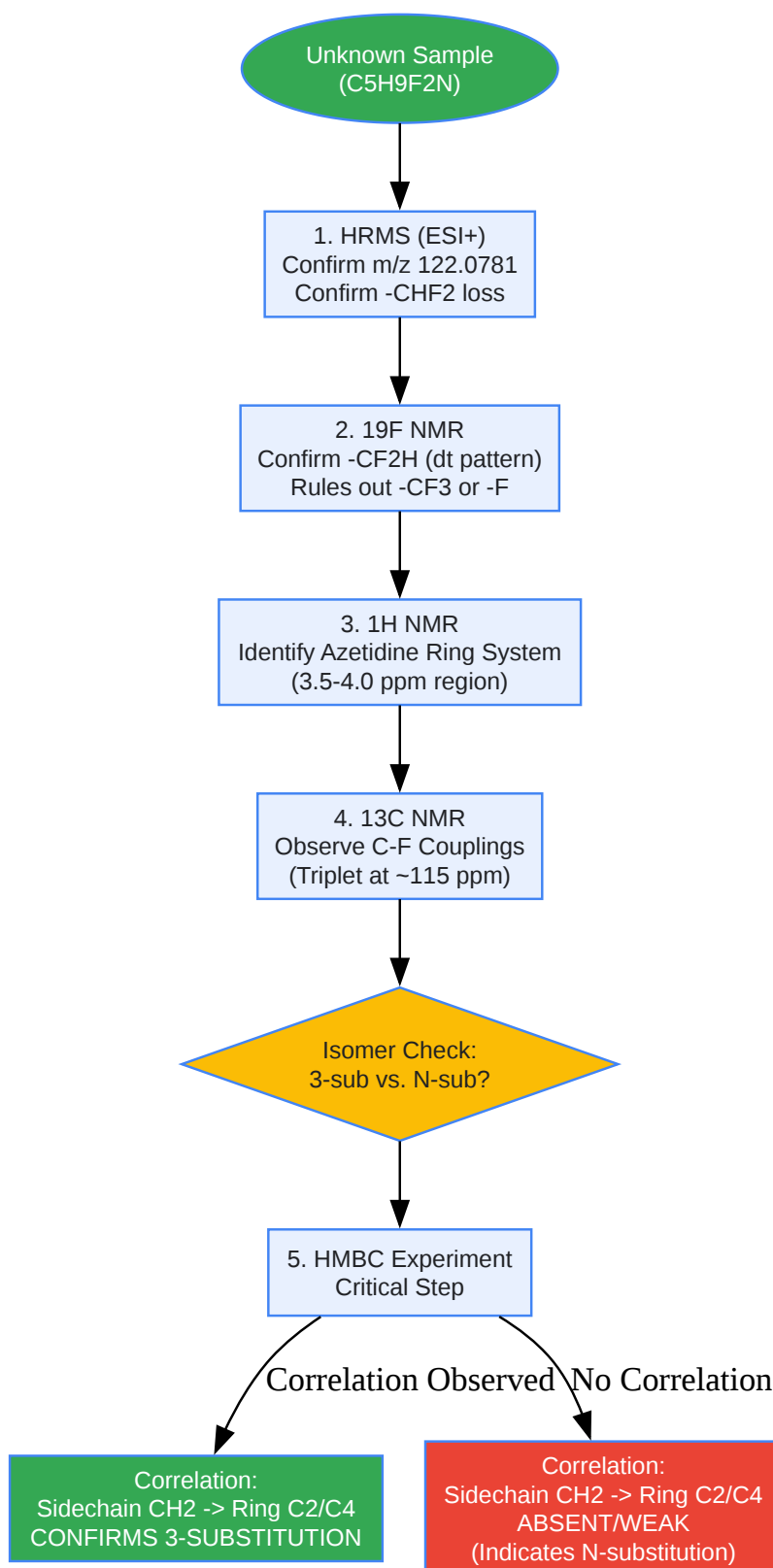

[Click to download full resolution via product page](#)

Caption: Step-by-step logic flow for confirming the 3-substituted azetidine structure over potential isomers.

2D NMR Correlation Map

This diagram details exactly which cross-peaks establish the connectivity.

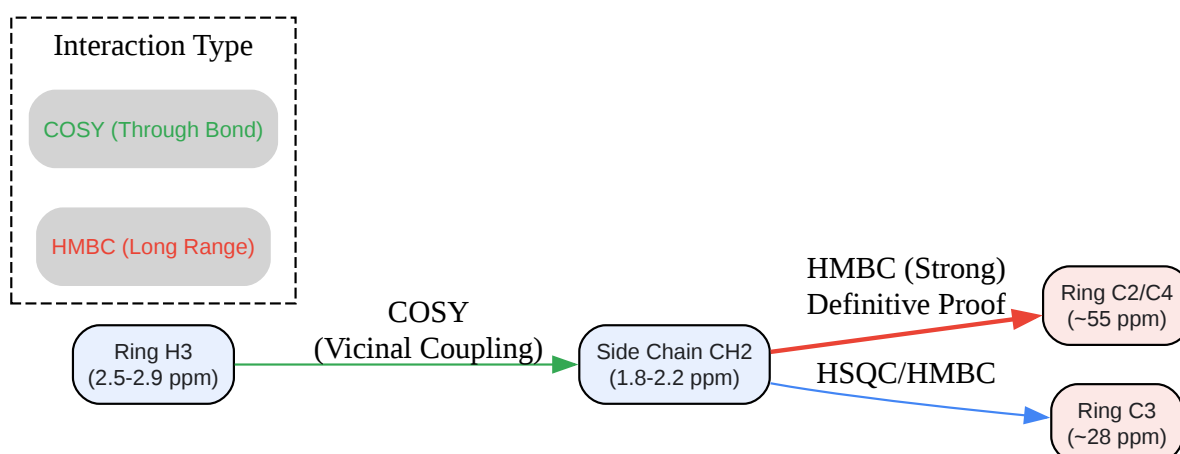

[Click to download full resolution via product page](#)

Caption: Critical 2D NMR correlations. The HMBC from Side Chain CH2 to Ring C2/C4 is the "smoking gun" for 3-substitution.

Part 5: Quality Control & Self-Validation Protocol

To ensure the data is trustworthy (Trustworthiness pillar), perform the following checks:

- The "Salt Shift" Check:
 - If the sample is an HCl salt, the -protons (C2/C4) will shift downfield significantly () compared to the free base.
 - Validation: Add a drop of

+

to the NMR tube. If the peaks shift upfield, it was a salt.

- Chiral Purity (If applicable):
 - While **3-(2,2-difluoroethyl)azetidine** is achiral, if the azetidine has another substituent (making it chiral), the diastereotopic nature of the protons will increase complexity (ABX systems).
 - Protocol: Acquire spectra at high temperature () to average out ring puckering conformers if line broadening is observed.
- Solvent Residuals:
 - Verify no overlap between the triplet () and solvent peaks (e.g., Dichloromethane at).

References

- Pretsch, E., Bühlmann, P., & Badertscher, M. (2009). Structure Determination of Organic Compounds: Tables of Spectral Data. Springer.[1] [Link](#)
- Dolbier, W. R. (2009). Guide to Fluorine NMR for Organic Chemists. Wiley. [Link](#)
- Couty, F., & Evano, G. (2006). "Azetidines: New Tools for the Synthesis of Nitrogen Heterocycles". Organic Preparations and Procedures International. [Link](#)
- Hu, J., Zhang, W., & F. K. (2005). "Selective Difluoromethylation and Monofluoromethylation Reactions". Chemical Reviews. (Context on Difluoroethyl group properties). [Link](#)

Need Custom Synthesis?

BenchChem offers custom synthesis for rare earth carbides and specific isotopic labeling.

Email: info@benchchem.com or [Request Quote Online](#).

Sources

- 1. Azetidine | C₃H₇N | CID 10422 - PubChem [pubchem.ncbi.nlm.nih.gov]
- To cite this document: BenchChem. [Technical Guide: Structural Elucidation of 3-(2,2-Difluoroethyl)azetidine]. BenchChem, [2026]. [Online PDF]. Available at: [<https://www.benchchem.com/product/b3246534/docs#technical-guide-structural-elucidation-of-3-2-2-difluoroethyl-azetidine>]

Disclaimer & Data Validity:

The information provided in this document is for Research Use Only (RUO) and is strictly not intended for diagnostic or therapeutic procedures. While BenchChem strives to provide accurate protocols, we make no warranties, express or implied, regarding the fitness of this product for every specific experimental setup.

Technical Support: The protocols provided are for reference purposes. Unsure if this reagent suits your experiment?

Need Industrial/Bulk Grade? [Request Custom Synthesis Quote](#)

BenchChem

Our mission is to be the trusted global source of essential and advanced chemicals, empowering scientists and researchers to drive progress in science and industry.

Contact

Address: 3281 E Guasti Rd

Ontario, CA 91761, United States

Phone: (601) 213-4426

Email: info@benchchem.com

Contact our Ph.D. Support Team for a compatibility check