

# Technical Support Center: Advanced Troubleshooting for UAA Peptide Synthesis

**Author:** BenchChem Technical Support Team. **Date:** April 2026

## Compound of Interest

**Compound Name:** 5-amino-4-fluoro-2-methylphenol;sulfuric acid

**CAS No.:** 163183-01-5

**Cat. No.:** B3244696

[Get Quote](#)

**Mission Statement:** This guide addresses the non-standard challenges of incorporating Unnatural Amino Acids (UAAs) into Solid Phase Peptide Synthesis (SPPS). Unlike canonical residues, UAAs introduce unique steric, electronic, and solubility hurdles. This resource is designed for researchers requiring actionable, mechanistic solutions for failed syntheses.

## Module 1: The Coupling Barrier (Steric Hindrance)

**The Issue:** “My LC-MS shows a deletion sequence (M-1) exactly at the UAA position. The Kaiser test remains positive despite double coupling.”

**The Mechanism:** UAAs like

-disubstituted amino acids (e.g., Aib) or

-methylated residues introduce massive steric bulk. This bulk prevents the incoming activated amino acid from approaching the N-terminus of the growing chain. Standard reagents (HBTU/HCTU) often fail because their half-life is shorter than the slow diffusion rate required for these bulky couplings.

## Troubleshooting Workflow: Steric Failure

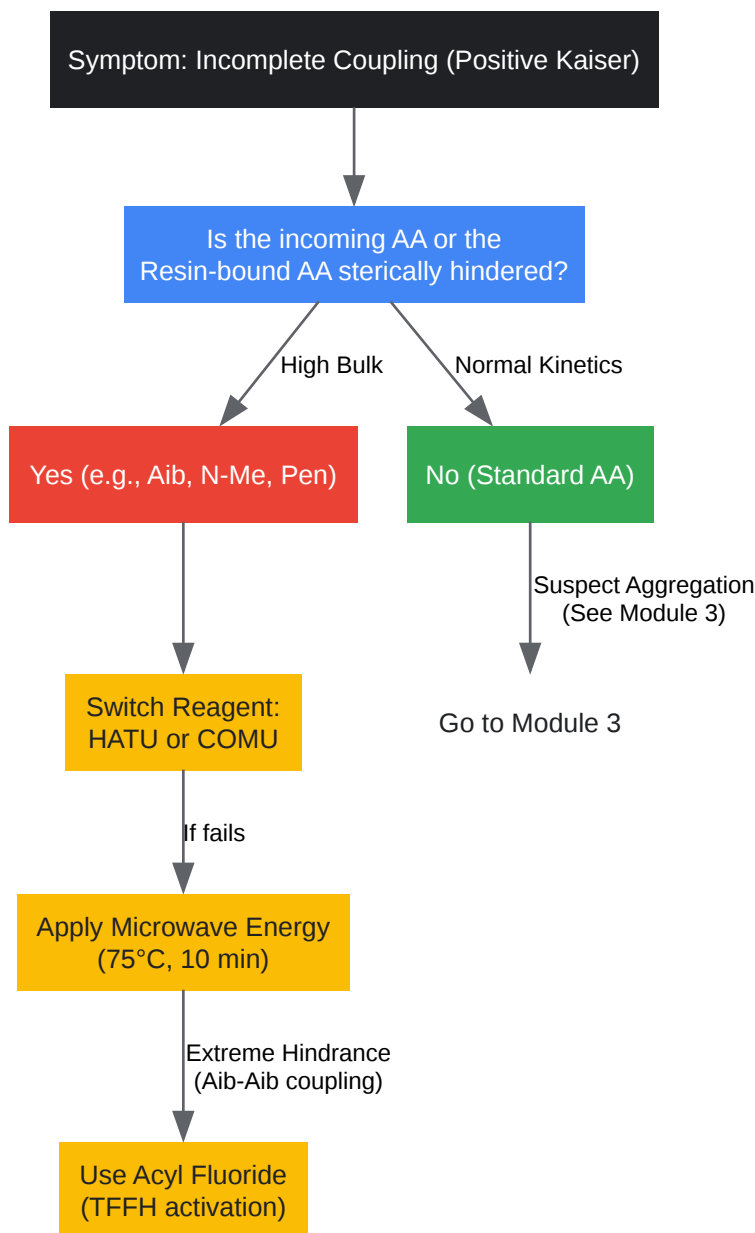

[Click to download full resolution via product page](#)

Caption: Decision matrix for diagnosing and resolving incomplete couplings caused by steric hindrance.

## Protocol 1: High-Efficiency Coupling for Hindered UAAs

Objective: Overcome the kinetic barrier of

-methyl or

-methyl amino acids.

- Reagent Selection: Switch from HBTU/DIC to HATU (1-[Bis(dimethylamino)methylene]-1H-1,2,3-triazolo[4,5-b]pyridinium 3-oxid hexafluorophosphate) or COMU.
  - Why: The aza-benzotriazole moiety in HATU utilizes the "neighboring group effect" (anchimeric assistance) via the pyridine nitrogen, accelerating the reaction rate by ~100x compared to HBTU [1].
- Base Optimization: Use HOAt (1-Hydroxy-7-azabenzotriazole) as an additive if using DIC.
- Microwave Assistance:
  - Temperature: 75°C.
  - Time: 2 x 5 minutes (Double couple).
  - Power: 30-50W (maintain temperature, avoid overshoot).

Data: Coupling Efficiency Comparison

Reagent	Coupling Efficiency (Aib-Aib Model)	Racemization Risk	Recommended Use
HBTU/DIEA	< 10% (Failed)	Low	Standard residues only.
DIC/Oxyma	~ 60%	Very Low	Sensitive UAAs (Cys/His derivatives).
HATU/DIEA	> 95%	High	Sterically hindered UAAs (Aib, N-Me).
COMU/DIEA	> 98%	Moderate	Safer alternative to HATU (non-explosive).

## Module 2: The Stereochemical Trap (Racemization)

The Issue: "My peptide mass is correct, but HPLC shows a split peak or a shoulder. I suspect I've lost chirality at the UAA."

The Mechanism: Racemization primarily occurs via the oxazolone mechanism. When the carboxyl group is activated, the carbonyl oxygen of the preceding amide bond can attack the activated center, forming a 5(4H)-oxazolone. This intermediate can readily lose its

-proton in the presence of base (like DIPEA), leading to epimerization. UAAs with electron-withdrawing side chains (e.g., Phenylglycine, Cys derivatives) are hypersensitive.

### Protocol 2: Racemization-Free Coupling

Objective: Couple sensitive UAAs (Cys, His, Phenylglycine analogs) without epimerization.

- Eliminate Strong Bases: Do NOT use HATU/DIEA. The basicity of DIEA promotes proton abstraction.
- The "Collidine" System:
  - Activator: DIC (Diisopropylcarbodiimide).<sup>[1][2]</sup>
  - Additive: Oxyma Pure (Ethyl cyanoglyoxylate-2-oxime).
  - Base: Sym-collidine (2,4,6-Trimethylpyridine).
  - Why: Collidine is a weaker base than DIEA, sufficient to neutralize the acid but insufficient to abstract the -proton <sup>[2]</sup>. Oxyma Pure creates an active ester that is less prone to oxazolone formation than HOBt.
- Temperature Control:
  - Strictly Room Temperature or 50°C max if using microwave. Never exceed 50°C for Cys/His UAAs.

## Module 3: The Solubility Wall (Aggregation)

The Issue: "Synthesis proceeds well for 10 residues, then fails completely. The resin volume has visibly shrunk."

The Mechanism: This is "On-Resin Aggregation."<sup>[3]</sup> As the peptide grows, inter-chain hydrogen bonds form between the backbone amides, creating

-sheet structures.<sup>[3]</sup><sup>[4]</sup> This collapses the resin matrix, burying the N-terminus and making it inaccessible to reagents.<sup>[3]</sup>

## Troubleshooting Workflow: Breaking Beta-Sheets

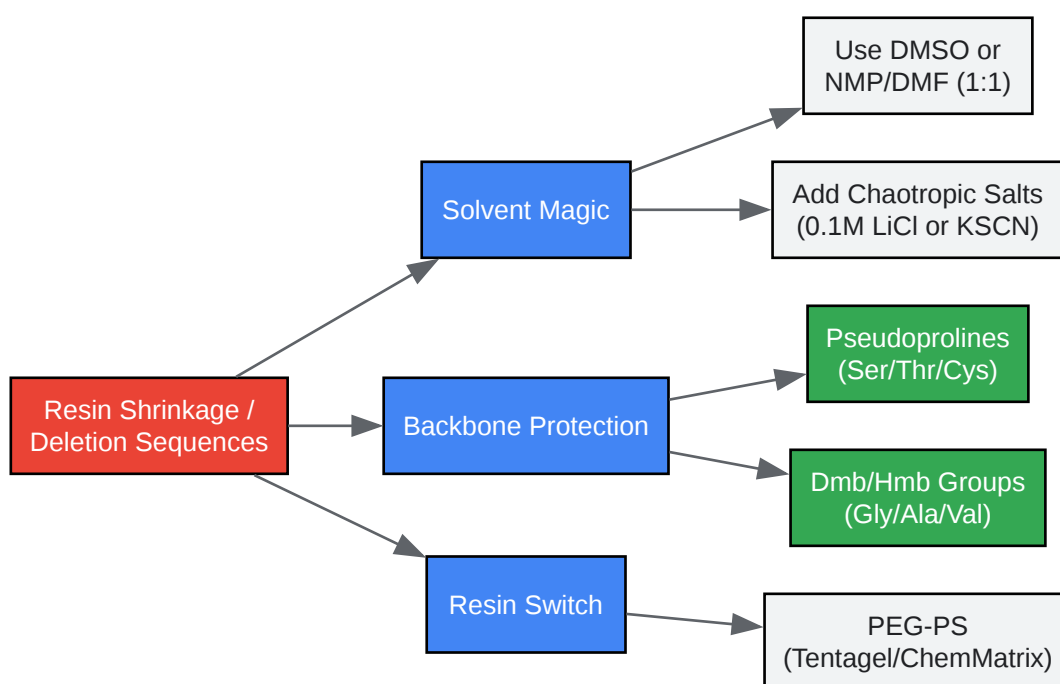

[Click to download full resolution via product page](#)

Caption: Three-pronged strategy to disrupt beta-sheet aggregation during SPPS.

## Protocol 3: The "Magic Mixture" & Backbone Protection

Objective: Disrupt inter-chain H-bonding.

- Chemical Disruption (The Solvent Fix):
  - Replace standard DMF with NMP (N-methylpyrrolidone) or a mixture of DMF/DMSO (1:1).

- Advanced: Use "Magic Mixture": DCM/DMF/NMP (1:1:1) with 1% Triton X-100.
- Structural Disruption (The Pseudoproline Fix):
  - Insert Pseudoprolines (oxazolidine dipeptides) at intervals of 5-6 residues.
  - Why: The cyclic structure acts as a "kink" in the backbone (cis-amide preference), physically preventing  $\alpha$ -sheet alignment [3].
  - Note: Upon TFA cleavage, the pseudoproline converts back to the native Ser/Thr/Cys.[5]
- Dmb Protection:
  - For Gly, Ala, or Val residues, use Fmoc-AA-(Dmb)Gly-OH. The Dmb group on the backbone nitrogen sterically blocks H-bonding.[3][5]

## FAQ: Specific UAA Scenarios

Q: I am using an Fmoc-N-methyl amino acid. The coupling onto this residue (the next step) is failing. Why? A: Coupling onto an N-methyl group is chemically difficult because it is a secondary amine with significant steric hindrance.[6][7]

- Solution: Use HATU or PyBroP.[7]
- Critical Step: Verify the coupling with the Chloranil Test (for secondary amines), not the Kaiser Test (which detects primary amines). The Chloranil test turns blue for secondary amines; if it stays yellow/colorless, coupling is complete.

Q: My UAA has a thioamide bond (to mimic the peptide bond). It degrades during cleavage. A: Thioamides are susceptible to the Edman degradation mechanism or cyclization during acidic cleavage.

- Solution: You must use the "Thioimidate" strategy or specialized cocktails. Avoid standard scavengers that might alkylate the sulfur.

- Cleavage: Use a high concentration of EDT (Ethanedithiol) and minimize water content to prevent hydrolysis of the thioamide.

Q: I need to couple a UAA that is an expensive intermediate. I can't afford 5 equivalents. A: Reduce the scale and concentration.

- Solution: Use Microwave-Assisted SPPS.<sup>[8][9][10][11]</sup> You can often drop to 1.5 - 2 equivalents because the thermal energy drives the reaction to completion efficiently.
- Vessel: Use a smaller reaction vessel (e.g., 2 mL vial) to keep the concentration high (>0.2 M) even with lower absolute mass.

## References

- Carpino, L. A. (1993). 1-Hydroxy-7-azabenzotriazole.<sup>[2]</sup> An efficient peptide coupling additive.<sup>[1][2][6][8][9]</sup> Journal of the American Chemical Society, 115(10), 4397-4398. [Link](#)
- Subirós-Funosas, R., et al. (2009). Oxyma: An Efficient Additive for Peptide Synthesis to Replace the Benzotriazole-Based HOBt and HOAt with a Lower Risk of Explosion. Chemistry – A European Journal, 15(37), 9394-9403. [Link](#)
- Mutter, M., et al. (1995).<sup>[12]</sup> Pseudoprolines: peptide bond isosteres for structure disruption in solid phase peptide synthesis.<sup>[5]</sup> Journal of the American Chemical Society, 117(36), 9115-9123. [Link](#)
- Albericio, F., & Tulla-Puche, J. (2008). The status of the art of the synthesis of N-methylated peptides. Chemical Reviews, 108, 3708-3720. [Link](#)

### Need Custom Synthesis?

BenchChem offers custom synthesis for rare earth carbides and specific isotopic labeling.

Email: [info@benchchem.com](mailto:info@benchchem.com) or [Request Quote Online](#).

## Sources

- 1. [pdf.benchchem.com](https://pdf.benchchem.com) [[pdf.benchchem.com](https://pdf.benchchem.com)]

- [2. peptide.com \[peptide.com\]](#)
- [3. peptidechemistry.org \[peptidechemistry.org\]](#)
- [4. chempep.com \[chempep.com\]](#)
- [5. peptide.com \[peptide.com\]](#)
- [6. pdf.benchchem.com \[pdf.benchchem.com\]](#)
- [7. peptide.com \[peptide.com\]](#)
- [8. Microwave-Assisted Solid-Phase Peptide Synthesis \(MW-SPPS\) Technology - Therapeutic Proteins & Peptides - CD Formulation \[formulationbio.com\]](#)
- [9. biotage.com \[biotage.com\]](#)
- [10. bachem.com \[bachem.com\]](#)
- [11. pdf.benchchem.com \[pdf.benchchem.com\]](#)
- [12. Challenges and Perspectives in Chemical Synthesis of Highly Hydrophobic Peptides - PMC \[pmc.ncbi.nlm.nih.gov\]](#)
- To cite this document: BenchChem. [Technical Support Center: Advanced Troubleshooting for UAA Peptide Synthesis]. BenchChem, [2026]. [Online PDF]. Available at: [\[https://www.benchchem.com/product/b3244696/docs#technical-support-center-advanced-troubleshooting-for-uaa-peptide-synthesis\]](https://www.benchchem.com/product/b3244696/docs#technical-support-center-advanced-troubleshooting-for-uaa-peptide-synthesis)

---

### Disclaimer & Data Validity:

The information provided in this document is for Research Use Only (RUO) and is strictly not intended for diagnostic or therapeutic procedures. While BenchChem strives to provide accurate protocols, we make no warranties, express or implied, regarding the fitness of this product for every specific experimental setup.

**Technical Support:** The protocols provided are for reference purposes. Unsure if this reagent suits your experiment?

**Need Industrial/Bulk Grade?** [Request Custom Synthesis Quote](#)

# BenchChem

Our mission is to be the trusted global source of essential and advanced chemicals, empowering scientists and researchers to drive progress in science and industry.

## Contact

Address: 3281 E Guasti Rd  
Ontario, CA 91761, United States  
Phone: (601) 213-4426  
Email: [info@benchchem.com](mailto:info@benchchem.com)

[Contact our Ph.D. Support Team for a compatibility check](#)