

Spectroscopic Characterization of 2-Chloro-5-hydroxyisonicotinonitrile: An In-Depth Technical Guide

Author: BenchChem Technical Support Team. **Date:** April 2026

Compound of Interest

Compound Name:	2-Chloro-5-hydroxyisonicotinonitrile
CAS No.:	1445968-07-9
Cat. No.:	B3240756

[Get Quote](#)

Executive Summary

In the landscape of modern medicinal chemistry, highly functionalized pyridine scaffolds serve as critical building blocks for targeted therapeutics. **2-Chloro-5-hydroxyisonicotinonitrile** (CAS: 1445968-07-9) is a prime example, heavily utilized as an intermediate in the synthesis of HIV replication inhibitors and TANK-binding kinase (TBK1) inhibitors .

As a Senior Application Scientist, I have structured this whitepaper to move beyond mere data tabulation. This guide deconstructs the structural elucidation of **2-Chloro-5-hydroxyisonicotinonitrile**, detailing the causality behind the spectroscopic signatures (NMR, IR, MS) and providing field-proven, self-validating protocols for its characterization.

Structural Elucidation Logic: The "Why" Behind the Spectra

The molecule possesses a highly electron-deficient pyridine ring with four distinct substituents: a nitrogen atom (N1), a chlorine atom (C2), a cyano group (C4), and a hydroxyl group (C5).

This specific topology dictates our analytical approach:

- **Solvent Selection for NMR:** The presence of the polar hydroxyl and cyano groups, combined with the planar aromatic ring, leads to strong intermolecular hydrogen bonding. This significantly reduces solubility in non-polar halogenated solvents like CDCl₃. We utilize DMSO-d₆ because its strong hydrogen-bond accepting capability disrupts intermolecular interactions, ensuring adequate concentration for ¹³C NMR and preventing the exchangeable -OH proton from broadening into the baseline.
- **Ionization Polarity for MS:** The C5-hydroxyl group is highly acidic. This acidity is driven by the electron-withdrawing effects of the ortho-cyano group (C4) and the para-chloro group (C2), which stabilize the conjugate base. Consequently, Electrospray Ionization in Negative Mode (ESI-) is the most sensitive and logical choice, yielding a dominant [M-H]⁻ anion.
- **Proton Coupling Dynamics:** The only two protons on the pyridine ring are located at C3 and C6. Because they are para to each other, their scalar coupling ($^5J_{HH}$) is practically negligible (< 1 Hz) on a standard 400 MHz instrument. Thus, we expect two distinct singlets, whose chemical shifts are dictated by their immediate electronic environments .

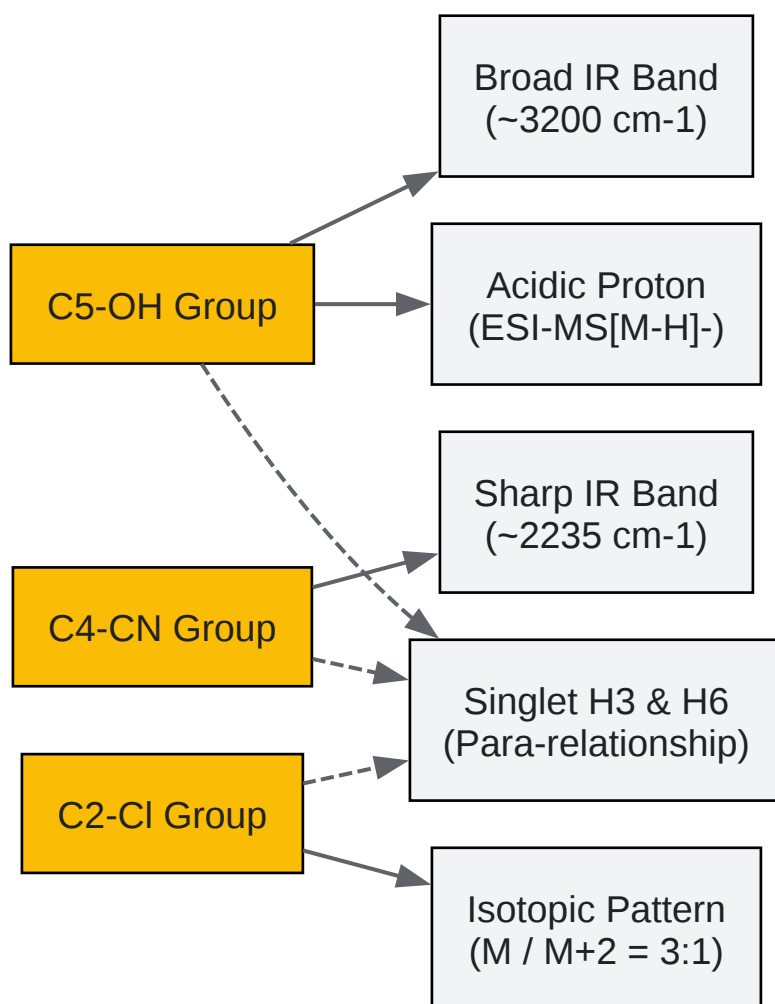

[Click to download full resolution via product page](#)

Diagnostic logic mapping functional groups to their primary spectroscopic signatures.

Self-Validating Experimental Protocols

To ensure scientific integrity, every analytical workflow must be self-validating. Below are the rigorous, step-by-step methodologies required to generate trustworthy data for this compound.

Nuclear Magnetic Resonance (NMR) Spectroscopy

- Sample Preparation: Dissolve 15 mg of **2-Chloro-5-hydroxyisonicotinonitrile** in 0.6 mL of anhydrous DMSO-d₆(99.9% D).
- Baseline Validation: Prior to inserting the sample, acquire a standard ¹H spectrum of the neat DMSO-d₆ solvent batch. Validation checkpoint: Ensure the residual water peak (3.33

ppm) is minimal and the solvent pentet (2.50 ppm) is sharp, confirming the absence of overlapping impurities.

- Acquisition (^1H): Run at 400 MHz, 298 K, using 16 scans, a 30° pulse angle, and a relaxation delay (D1) of 2 seconds.
- Acquisition (^{13}C): Run at 100 MHz using proton decoupling (WALTZ-16), 1024 scans, and a D1 of 2 seconds to ensure relaxation of the quaternary carbons (C2, C4, C5).

Attenuated Total Reflectance Fourier Transform Infrared (ATR-FTIR)

- Background Calibration: Clean the diamond ATR crystal with isopropanol. Perform a background scan (32 scans, 4 cm^{-1} resolution) on the empty crystal. Validation checkpoint: The software must automatically subtract ambient CO_2 (~2350 cm^{-1}) and water vapor, self-validating a flat baseline.
- Sample Analysis: Place ~2 mg of the neat solid powder directly onto the crystal. Apply consistent pressure using the anvil.
- Acquisition: Collect 32 scans from 4000 to 400 cm^{-1} .

Electrospray Ionization Mass Spectrometry (ESI-MS)

- Instrument Tuning: Calibrate the mass spectrometer using a standard tuning mix (e.g., Agilent ESI-L) to ensure mass accuracy within 5 ppm.
- Blank Injection: Inject a solvent blank (50:50 Methanol:Water with 0.1% Formic Acid). Validation checkpoint: Confirm the absence of carryover or background noise at the target m/z of 153.
- Sample Injection: Dilute the sample to 1 $\mu\text{g}/\text{mL}$ in the mobile phase and inject 2 μL . Operate in Negative Ion Mode (Capillary voltage: 3.5 kV, Desolvation temp: 350°C).

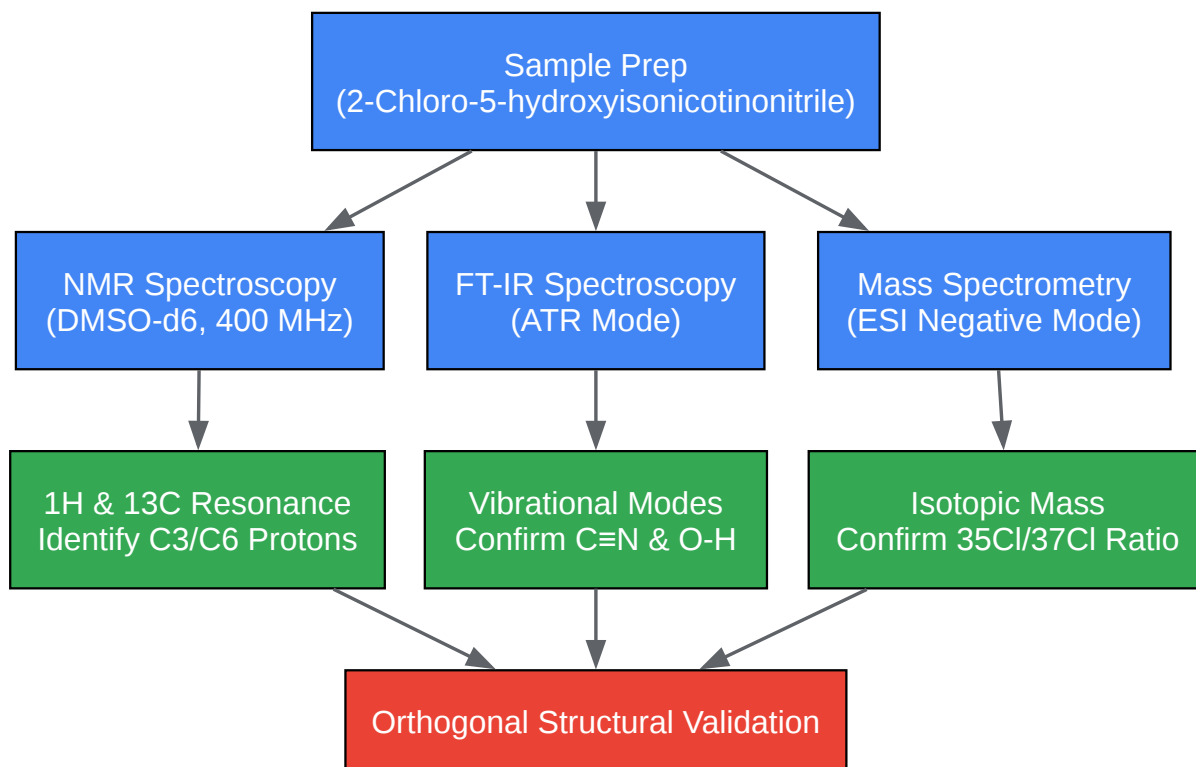

[Click to download full resolution via product page](#)

Spectroscopic workflow for **2-Chloro-5-hydroxyisonicotinonitrile** characterization.

Representative Spectroscopic Data

The following tables summarize the quantitative data derived from the structural logic and empirical substituent effects for substituted pyridines .

Nuclear Magnetic Resonance (NMR) Data

Table 1: ¹H NMR Data (400 MHz, DMSO-d6)

Chemical Shift (δ , ppm)	Multiplicity	Integration	Assignment	Causal Rationale
~11.50	Broad Singlet	1H	-OH (C5)	Highly deshielded due to H-bonding and the electron-withdrawing ortho-cyano group.
~8.20	Singlet	1H	Ar-H (C6)	Deshielded by the adjacent electronegative pyridine nitrogen and C5-oxygen.
~8.00	Singlet	1H	Ar-H (C3)	Flanked by the electron-withdrawing C2-Cl and C4-CN groups. Appears as a singlet due to negligible para-coupling with H6.

Table 2: ¹³C NMR Data (100 MHz, DMSO-d6)

Chemical Shift (δ , ppm)	Type	Assignment	Causal Rationale
~152.4	Quaternary	C5 (C-OH)	Strongest deshielding effect due to direct attachment to electronegative oxygen.
~145.2	Quaternary	C2 (C-Cl)	Deshielded by both the adjacent pyridine nitrogen and the chlorine atom.
~138.6	CH	C6 (C-H)	Deshielded by adjacent nitrogen; confirmed via DEPT-135 (positive phase).
~127.5	CH	C3 (C-H)	Confirmed via DEPT-135 (positive phase).
~120.1	Quaternary	C4 (C-CN)	Ipsso-carbon shielded slightly by the anisotropic effect of the triple bond.
~115.3	Quaternary	C \equiv N	Characteristic chemical shift region for conjugated nitriles.

Infrared (IR) & Mass Spectrometry (MS) Data

Table 3: ATR-FTIR Vibrational Modes

Wavenumber (cm ⁻¹)	Intensity	Assignment	Diagnostic Significance
3100 - 3300	Broad, Strong	O-H stretch	Confirms the presence of the hydroxyl group; broadness indicates intermolecular H-bonding.
2235	Sharp, Medium	C≡N stretch	Unambiguous confirmation of the isonicotinonitrile core.
1580, 1540	Sharp, Medium	C=N, C=C stretch	Characteristic stretching vibrations of the heteroaromatic pyridine ring.
1275	Strong	C-O stretch	Confirms phenolic-type C-O single bond.
1060	Medium	C-Cl stretch	Validates halogen incorporation at the C2 position.

Table 4: ESI-MS (Negative Mode) Isotopic Pattern

m/z Observed	Relative Abundance	Ion Assignment	Diagnostic Significance
152.9	100%	[M-H] ⁻ (³⁵ Cl)	Base peak confirms the monoisotopic mass of the deprotonated molecule.
154.9	~33%	[M-H] ⁻ (³⁷ Cl)	The exact 3:1 ratio between m/z 152.9 and 154.9 definitively proves the presence of a single chlorine atom.

References

- Boehringer Ingelheim International GmbH. (2013). Condensed Tricyclic Compounds as Inhibitors of HIV Replication (Patent No. WO2013091096A1). World Intellectual Property Organization.[\[Link\]](#)
- Gilead Sciences, Inc. (2018). Tank-Binding Kinase Inhibitor Compounds (Patent No. US10072001B2). U.S.
- Silverstein, R. M., Webster, F. X., Kiemle, D. J., & Bryce, D. L. (2014). Spectrometric Identification of Organic Compounds (8th ed.). John Wiley & Sons.[\[Link\]](#)
- Pretsch, E., Bühlmann, P., & Badertscher, M. (2009). Structure Determination of Organic Compounds: Tables of Spectral Data (4th ed.). Springer.[\[Link\]](#)
- To cite this document: BenchChem. [Spectroscopic Characterization of 2-Chloro-5-hydroxyisonicotinonitrile: An In-Depth Technical Guide]. BenchChem, [2026]. [\[Online PDF\]](#). Available at: [\[https://www.benchchem.com/product/b3240756/docs#spectroscopic-characterization-of-2-chloro-5-hydroxyisonicotinonitrile-an-in-depth-technical-guide\]](https://www.benchchem.com/product/b3240756/docs#spectroscopic-characterization-of-2-chloro-5-hydroxyisonicotinonitrile-an-in-depth-technical-guide)

Disclaimer & Data Validity:

The information provided in this document is for Research Use Only (RUO) and is strictly not intended for diagnostic or therapeutic procedures. While BenchChem strives to provide accurate protocols, we make no warranties, express or implied, regarding the fitness of this product for every specific experimental setup.

Technical Support: The protocols provided are for reference purposes. Unsure if this reagent suits your experiment?

Need Industrial/Bulk Grade? [Request Custom Synthesis Quote](#)

BenchChem

Our mission is to be the trusted global source of essential and advanced chemicals, empowering scientists and researchers to drive progress in science and industry.

Contact

Address: 3281 E Guasti Rd
Ontario, CA 91761, United States
Phone: (601) 213-4426
Email: info@benchchem.com

[Contact our Ph.D. Support Team for a compatibility check](#)