

Application Note: 3-Fluoro-5-azaindole as a Fragment for FBDD

Author: BenchChem Technical Support Team. **Date:** April 2026

Compound of Interest

Compound Name: 3-Fluoro-5-azaindole

CAS No.: 1352395-99-3

Cat. No.: B3233266

[Get Quote](#)

Executive Summary

This application note details the utility, synthesis, and screening protocols for **3-Fluoro-5-azaindole** (3-fluoro-1H-pyrrolo[3,2-c]pyridine) as a high-value scaffold in Fragment-Based Drug Discovery (FBDD).

While the 7-azaindole scaffold is ubiquitous in kinase research, the 5-azaindole isomer offers a distinct vector for chemical space exploration, particularly for targets requiring alternative hydrogen bond donor/acceptor geometries. The incorporation of a fluorine atom at the C3 position serves a dual purpose: it acts as a sensitive

F NMR spy label for ligand-observed screening and modulates the electronic properties of the pyrrole ring, potentially enhancing metabolic stability against oxidative metabolism at the otherwise reactive C3 site.

Physicochemical Profile & Rationale

The **3-fluoro-5-azaindole** fragment adheres strictly to the "Rule of Three" (Ro3) for fragments, ensuring that subsequent elaboration (hit-to-lead) does not violate drug-like property

thresholds.

Table 1: Physicochemical Properties

Property	Value	Rationale for FBDD
Molecular Weight	136.13 Da	Leaves significant mass "headroom" for elaboration (<300 Da).
cLogP	~1.2 - 1.5	Ideal lipophilicity range; ensures solubility in aqueous buffers for NMR/SPR.
H-Bond Donors (HBD)	1 (N1-H)	Critical for Hinge Binding (e.g., Kinase ATP pocket).
H-Bond Acceptors (HBA)	2 (N5, F)	N5 provides a unique vector compared to N7-azaindole.
PSA (Polar Surface Area)	~28 Å ²	High permeability potential.
F NMR Shift	~ -165 ppm	Distinct chemical shift window, avoiding overlap with trifluoromethyl standards.

Structural Advantages[1][2][3]

- Bioisosterism: The 5-azaindole core is an isostere of the indole ring (found in tryptophan) and purine (found in ATP), making it a "privileged scaffold" for kinases and GPCRs.
- Fluorine at C3:
 - Electronic Modulation: Fluorine is highly electronegative, lowering the pKa of the pyrrole NH, potentially strengthening hydrogen bonds with backbone carbonyls in protein targets.
 - Metabolic Blocking: The C3 position of indoles is prone to oxidation (e.g., by P450s). Fluorine substitution blocks this metabolic soft spot.

Experimental Protocol: Synthesis of 3-Fluoro-5-azaindole

While **3-fluoro-5-azaindole** is commercially available, in-house synthesis allows for the introduction of isotopic labels or specific derivatives. The most robust method involves electrophilic fluorination of the parent 5-azaindole.

Reagents

- Starting Material: 5-Azaindole (1H-pyrrolo[3,2-c]pyridine).
- Fluorinating Agent: Selectfluor™ (1-Chloromethyl-4-fluoro-1,4-diazoniabicyclo[2.2.2]octane bis(tetrafluoroborate)).
- Solvent: Acetonitrile (MeCN) or DMF.^[1]

Step-by-Step Synthesis

- Preparation: Dissolve 5-azaindole (1.0 eq) in anhydrous MeCN (0.1 M concentration) under an inert atmosphere ().
- Addition: Cool the solution to 0°C. Add Selectfluor™ (1.1 eq) portion-wise over 15 minutes to control the exotherm.
- Reaction: Allow the mixture to warm to room temperature (RT) and stir for 4–6 hours. Monitor via LC-MS (Target Mass: 137.1 M+H).
- Workup: Dilute with ethyl acetate and wash with saturated (aq) to neutralize HF byproducts.
- Purification: Dry organic layer over , concentrate, and purify via flash column chromatography (SiO₂, 0-10% MeOH in DCM).
- Yield: Typical yields range from 60–75%.

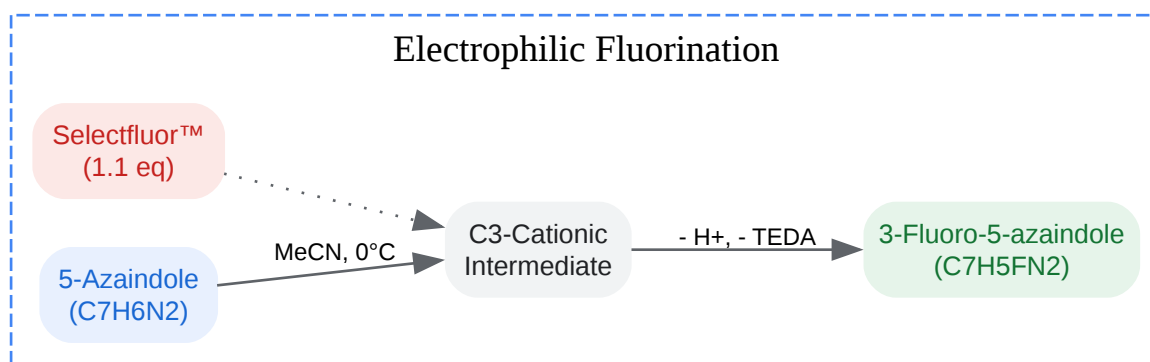

[Click to download full resolution via product page](#)

Caption: Electrophilic fluorination pathway using Selectfluor to install the fluorine atom at the C3 position.

Screening Protocol: Ligand-Observed F NMR

The primary screening method for this fragment is

F NMR CPMG (Carr-Purcell-Meiboom-Gill) relaxation dispersion. This technique detects binding by observing the reduction in the transverse relaxation time (

) of the ligand when it interacts with a large protein target.

Rationale

- No Protein Background: Proteins do not contain fluorine (unless labeled), resulting in a clean baseline.
- Sensitivity:
F has 83% the sensitivity of
H and 100% natural abundance.
- Speed: Mixtures of 10–20 fluorinated fragments can be screened simultaneously if chemical shifts are non-overlapping.

Materials

- Instrument: 600 MHz NMR with a
F-capable probe (e.g., Bruker QCI-F).
- Buffer: 50 mM Phosphate/Tris, 100 mM NaCl, 10%
(lock), pH 7.4.
- Protein: Target kinase (e.g., JAK, BRAF) at 10–20 μ M.
- Ligand: **3-Fluoro-5-azaindole** (and cocktail members) at 200–400 μ M.

Experimental Workflow

- Reference Spectrum (): Acquire a 1D
F NMR spectrum of the fragment cocktail without protein.
 - Parameter: Relaxation delay () = 2s; Scans = 64–128.
- CPMG Experiment (): Acquire the CPMG spectrum with protein.
 - Pulse Sequence: Standard CPMG train (e.g., cpmg1d in Bruker TopSpin).
 - T2 Filter: Apply a
filter of 50–200 ms. Large proteins tumble slowly; bound ligands will relax faster and their signal will be attenuated or disappear during the delay.
- Competition Assay (Validation): If a "hit" (signal reduction) is observed, add a known high-affinity inhibitor (competitor).
 - Result: If the fragment binds to the active site, the competitor will displace it, restoring the sharp, intense

F signal (Signal Recovery).

Data Interpretation[6][7][8][9][10]

- Hit: >30% reduction in peak intensity in the presence of protein compared to the reference.
- Binder: Line broadening (increase in FWHM) indicates intermediate exchange.
- Artifact: Chemical shift change without broadening may indicate non-specific change in pH or viscosity, though in

F this is often a sign of specific environmental change (Slow Exchange).

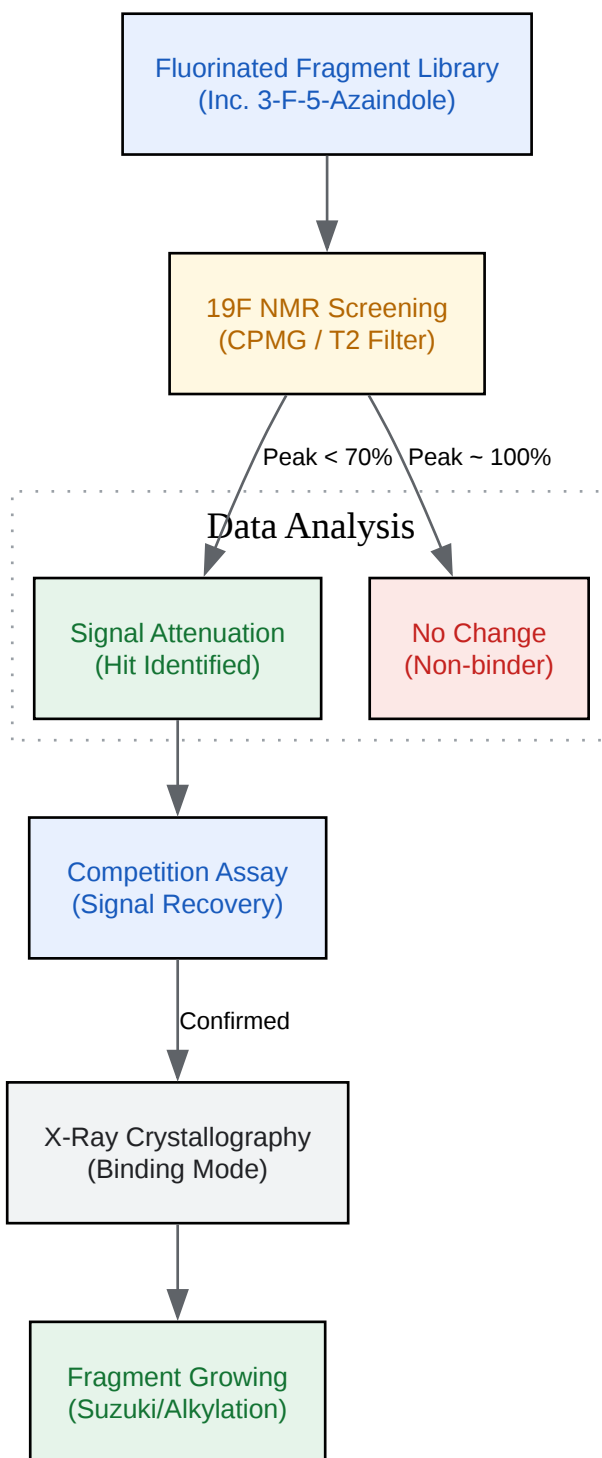

[Click to download full resolution via product page](#)

Caption: FBDD workflow for **3-Fluoro-5-azaindole**, moving from library screening via 19F NMR to structural validation and chemical elaboration.

Elaboration Strategy (Hit-to-Lead)

Once **3-fluoro-5-azaindole** is confirmed as a binder, the fragment must be "grown" to increase affinity. The scaffold offers distinct vectors for elaboration:

- N1-Alkylation: The pyrrole nitrogen is a nucleophile. Alkylation here usually projects into the solvent-exposed region or towards the ribose pocket of kinases.
- C2-Functionalization: Lithiation at C2 followed by reaction with electrophiles (or C-H activation) allows growth along the hinge region.
- C6-Coupling: If a halogen is introduced at C6 (e.g., starting with 6-chloro-**3-fluoro-5-azaindole**), Suzuki-Miyaura coupling can extend the molecule into the "back pocket" or "gatekeeper" region of the kinase.

Target Interaction Model (Kinase Hinge)

The 5-azaindole scaffold typically binds to the kinase hinge region via:

- Acceptor: N5 (Pyridine nitrogen) accepts a proton from the backbone NH.
- Donor: N1 (Pyrrole nitrogen) donates a proton to the backbone Carbonyl.

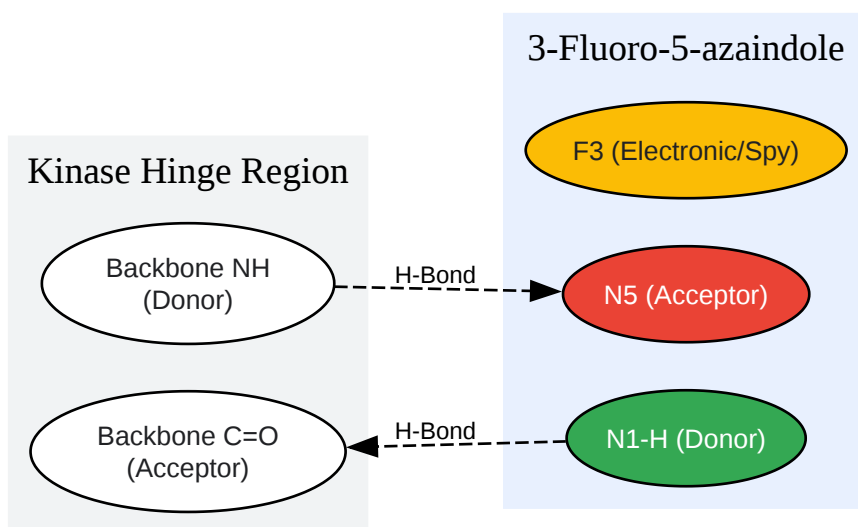

[Click to download full resolution via product page](#)

Caption: Predicted binding mode of 5-azaindole scaffold to a generic kinase hinge region, highlighting the Donor-Acceptor motif.

References

- Selectfluor Chemistry: Banks, R. E. (1992). Selectfluor™ reagent F-TEDA-BF4 in organic synthesis: A simple, efficient and safe source of electrophilic fluorine. .
- Azaindole Scaffolds: Popowycz, F., et al. (2014). The Azaindole Framework in the Design of Kinase Inhibitors. .
- ¹⁹F NMR Screening: Dalvit, C., et al. (2003). Fluorine-NMR Experiments for High-Throughput Screening: Theoretical Aspects and Practical Applications. .
- Fragment Library Design: Vulpetti, A., et al. (2009). Design and NMR Screening of a Fluorinated Fragment Library. .
- Commercial Sources: **3-Fluoro-5-azaindole** availability verified via and .

Need Custom Synthesis?

BenchChem offers custom synthesis for rare earth carbides and specific isotopic labeling.

Email: info@benchchem.com or [Request Quote Online](#).

Sources

- 1. The first application of Selectfluor™ in electrophilic fluorination of amines: a new route to –NF₂, –NHF, and >NF compounds - Chemical Communications (RSC Publishing) [pubs.rsc.org]
- To cite this document: BenchChem. [Application Note: 3-Fluoro-5-azaindole as a Fragment for FBDD]. BenchChem, [2026]. [Online PDF]. Available at: [<https://www.benchchem.com/product/b3233266/docs#application-note-3-fluoro-5-azaindole-as-a-fragment-for-fbdd>]

Disclaimer & Data Validity:

The information provided in this document is for Research Use Only (RUO) and is strictly not intended for diagnostic or therapeutic procedures. While BenchChem strives to provide accurate protocols, we make no warranties, express or implied, regarding the fitness of this product for every specific experimental setup.

Technical Support: The protocols provided are for reference purposes. Unsure if this reagent suits your experiment?

Need Industrial/Bulk Grade? [Request Custom Synthesis Quote](#)

BenchChem

Our mission is to be the trusted global source of essential and advanced chemicals, empowering scientists and researchers to drive progress in science and industry.

Contact

Address: 3281 E Guasti Rd
Ontario, CA 91761, United States
Phone: (601) 213-4426
Email: info@benchchem.com

[Contact our Ph.D. Support Team for a compatibility check](#)