

Technical Support Center: Troubleshooting Low Enantioselectivity in Chiral Amine Synthesis

Author: BenchChem Technical Support Team. **Date:** April 2026

Compound of Interest

Compound Name: (2-Amino-3-methylbutyl)
(benzyl)amine
CAS No.: 1248288-06-3
Cat. No.: B3225368

[Get Quote](#)

Current Status: Online Agent: Senior Application Scientist Ticket ID: CA-OPT-2024 Topic: Rectifying Low Enantiomeric Excess (ee) in Asymmetric Amine Synthesis

Introduction: The "Chiral Cliff"

Chiral amines are the pharmacophores of over 40% of small-molecule drugs.^[1] Whether you are employing Transition Metal Catalysis (Asymmetric Hydrogenation), Organocatalysis, or Biocatalysis (Transaminases), encountering a "chiral cliff"—where enantioselectivity unexpectedly drops—is a common bottleneck.

This guide is not a textbook; it is a diagnostic engine. We treat your reaction as a system with inputs (reagents, catalyst, environment) and outputs (conversion, ee). When the output fails, we isolate the variable responsible.

Module 1: Diagnostic Workflow (The "Is It Real?" Check)

Before optimizing reaction conditions, we must validate the data.^[2] 30% of reported "low ee" cases are actually analytical artifacts or contamination issues.

Visualizing the Troubleshooting Logic

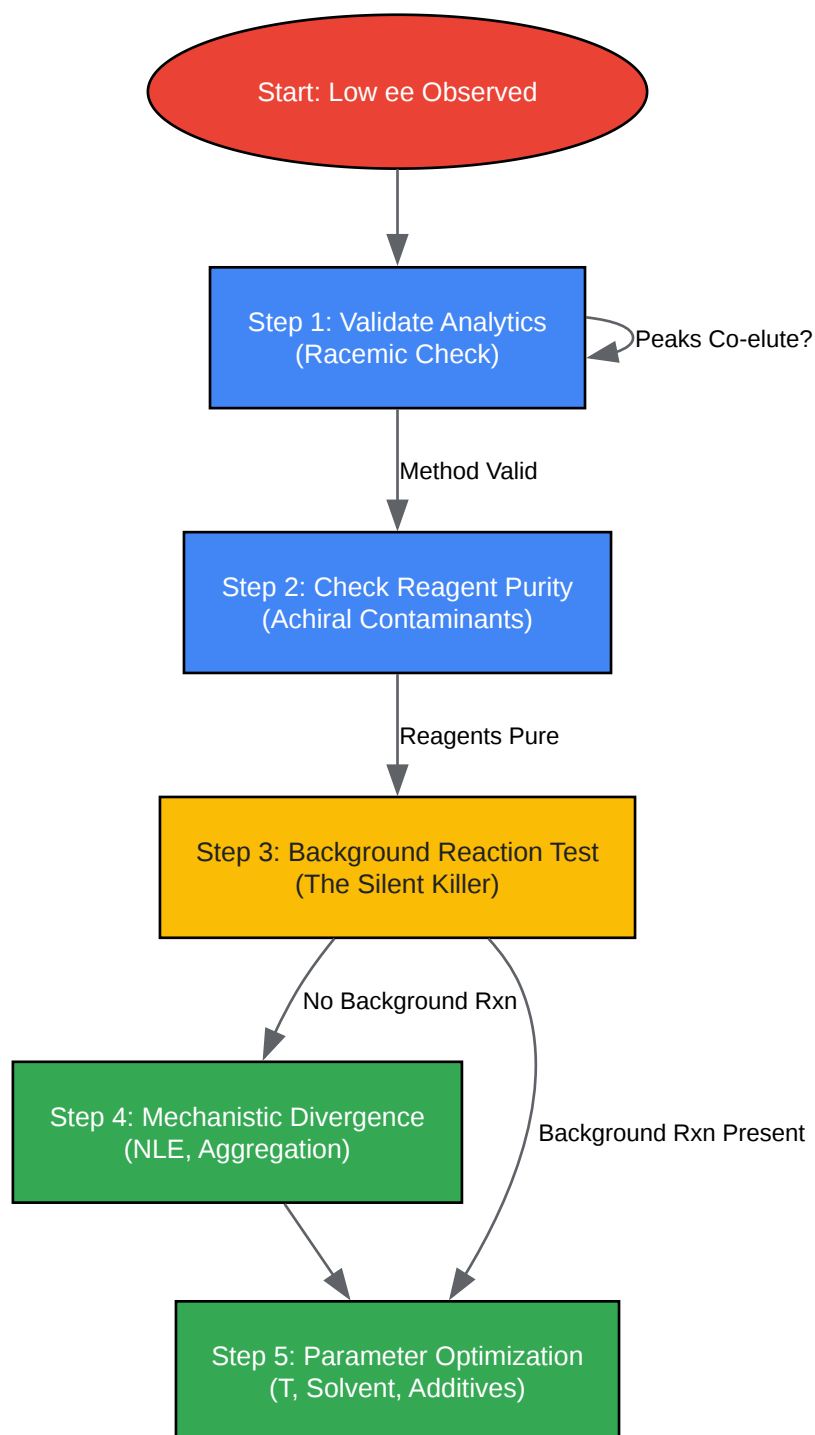

[Click to download full resolution via product page](#)

Figure 1: Systematic workflow for isolating the root cause of low enantioselectivity.

Module 2: Core Troubleshooting (Q&A)

Category A: The "Silent" Background Reaction

Q: My catalyst is famous for high selectivity (e.g., >95% ee in literature), but I am getting <50% ee. Is the catalyst dead?

A: Likely not. You are probably witnessing a competitive racemic background reaction. In asymmetric synthesis, two parallel reactions often occur:

- Catalyzed Pathway: Fast, highly enantioselective ().
- Uncatalyzed (Background) Pathway: Slow, racemic ().

If your reaction is slow (low turnover frequency), the background reaction begins to dominate the product distribution, eroding the final ee. This is common in imine hydrogenation and organocatalytic transfer hydrogenation.

Diagnostic Experiment: Run the reaction without the catalyst under identical conditions (solvent, T, time).

- Result A (0% Conversion): Good. No background reaction. The issue is catalyst deactivation or mismatch.
- Result B (>5% Conversion): Critical Issue. The background reaction is consuming your substrate racemically.

Corrective Actions:

- Lower the Temperature: Paradoxically, while this slows the reaction, it often suppresses the high-activation-energy background reaction (

) more than the catalyzed pathway (

), improving the ratio

.

- Increase Catalyst Loading: Accelerate the selective pathway to outcompete the background.

Category B: Catalyst Aggregation & Non-Linear Effects

Q: I increased the catalyst loading to improve rate, but the ee dropped. Shouldn't more catalyst be better?

A: This suggests a Negative Non-Linear Effect ((-)-NLE) caused by catalyst aggregation. Many chiral catalysts (especially organocatalysts and some metal-ligand complexes) can form dimers or oligomers in solution.

- Monomer: Active, highly selective.
- Dimer/Aggregate: Less active or non-selective (racemic).

At higher concentrations, the equilibrium shifts toward the aggregate.

Data Presentation: Concentration Effects

Parameter	Observation	Diagnosis	Solution
High Conc.	Low ee, Fast Rate	Aggregation (Active Racemic Species)	Dilute reaction (0.1 M → 0.01 M)
High Conc.	Low ee, Slow Rate	Aggregation (Inactive Species)	Dilute reaction; Check solubility
Low Conc.	Low ee	Background Reaction Dominance	Increase Conc. or Catalyst Loading

Corrective Action: Perform a dilution study. Run the reaction at 0.5M, 0.1M, and 0.05M. If ee improves at lower concentrations, aggregation is the culprit [1].

Category C: Product Inhibition & Autocatalysis

Q: The reaction starts with high ee (checked at 10% conversion), but the final isolated ee is low. Why?

A: This indicates Product Inhibition or Product-Catalyzed Racemization. Chiral amines are basic and nucleophilic. They can:

- Poison the Catalyst: Bind irreversibly to the metal center (e.g., Ir, Rh), shutting down the selective cycle.
- Act as a Base: Catalyze the racemization of the imine substrate or the product itself via enamine intermediates.

Visualizing the Interference

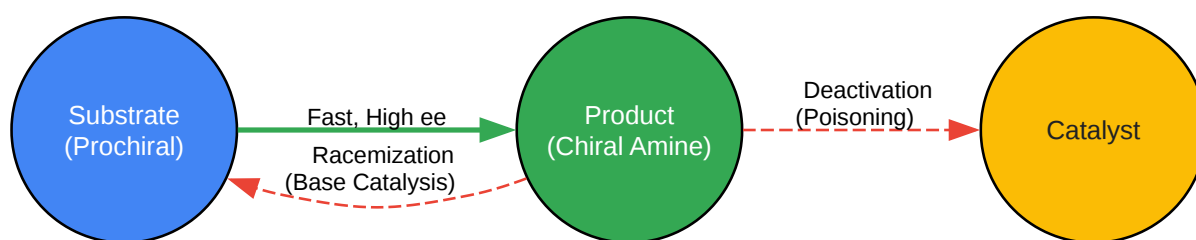

[Click to download full resolution via product page](#)

Figure 2: Feedback loops where the product interferes with the catalytic cycle.

Corrective Actions:

- Additives: For metal catalysis, add a non-coordinating acid (e.g., acetic acid) to protonate the product amine as it forms, preventing it from binding to the catalyst [2].
- Protecting Groups: Use N-protecting groups (e.g., Boc, Cbz) that reduce the basicity of the amine product.

Module 3: Advanced Optimization Protocols

Protocol A: The "RAC-Check" (Mandatory Self-Validation)

Never assume your chiral HPLC method is valid until you have separated the racemate.

- Synthesis: Mix 1 eq. of substrate with a non-chiral reducing agent (e.g., NaBH₄ for imines) or run the reaction with an achiral ligand (e.g., PPh₃).
- Analysis: Inject this racemic product onto your chiral column.
- Validation: You MUST see two distinct peaks with area integration ~50:50.
 - If 1 peak: Your method is not separating enantiomers. The "single peak" in your chiral reaction is not 100% ee; it's unresolved.
 - If 2 peaks: Calculate resolution ($R_s = \frac{2(t_R2 - t_R1)}{W_1 + W_2}$). Aim for $R_s > 1.5$ (baseline separation).

Protocol B: Biocatalytic Equilibrium Shift (Transaminases)

Issue: Transaminases are reversible. The reaction stops at 50% conversion or racemizes.

Workflow:

- Equilibrium Displacement: Use an amine donor that generates a volatile or unstable byproduct.
 - Donor: Isopropylamine
Byproduct: Acetone (Volatile, remove by open system/N₂ sweep).
 - Donor: Alanine
Byproduct: Pyruvate (Remove by adding Lactate Dehydrogenase + NADH to recycle) [3].

- Solvent Engineering: Add 10-20% DMSO to improve solubility of hydrophobic ketone substrates, but verify enzyme stability first.

References

- Satyanarayana, T., Abraham, S., & Kagan, H. B. (2009). Nonlinear Effects in Asymmetric Catalysis. *Angewandte Chemie International Edition*, 48(3), 456–494. [Link](#)
- Nugent, T. C., & El-Shazly, M. (2010). Chiral Amine Synthesis – Recent Developments and Trends for Enamide Reduction, Reductive Amination, and Imine Reduction. *Advanced Synthesis & Catalysis*, 352(5), 753–819. [Link](#)
- Koszelewski, D., et al. (2010). Omega-Transaminases for the Synthesis of Optically Pure Amines and Amino Acids.[1] *Trends in Biotechnology*, 28(6), 324–332. [Link](#)
- Verho, O., & Bäckvall, J. E. (2015). Chemoenzymatic Dynamic Kinetic Resolution: A Powerful Tool for the Synthesis of Enantiomerically Pure Compounds. *Journal of the American Chemical Society*, 137(12), 3996–4009. [Link](#)

Need Custom Synthesis?

BenchChem offers custom synthesis for rare earth carbides and specific isotopic labeling.

Email: info@benchchem.com or [Request Quote Online](#).

Sources

- 1. [Recent Advances in \$\omega\$ -Transaminase-Mediated Biocatalysis for the Enantioselective Synthesis of Chiral Amines \[mdpi.com\]](#)
- 2. [pdf.benchchem.com \[pdf.benchchem.com\]](#)
- To cite this document: BenchChem. [Technical Support Center: Troubleshooting Low Enantioselectivity in Chiral Amine Synthesis]. BenchChem, [2026]. [Online PDF]. Available at: [<https://www.benchchem.com/product/b3225368/docs#technical-support-center-troubleshooting-low-enantioselectivity-in-chiral-amine-synthesis>]

Disclaimer & Data Validity:

The information provided in this document is for Research Use Only (RUO) and is strictly not intended for diagnostic or therapeutic procedures. While BenchChem strives to provide accurate protocols, we make no warranties, express or implied, regarding the fitness of this product for every specific experimental setup.

Technical Support: The protocols provided are for reference purposes. Unsure if this reagent suits your experiment?

Need Industrial/Bulk Grade? [Request Custom Synthesis Quote](#)

BenchChem

Our mission is to be the trusted global source of essential and advanced chemicals, empowering scientists and researchers to drive progress in science and industry.

Contact

Address: 3281 E Guasti Rd
Ontario, CA 91761, United States
Phone: (601) 213-4426
Email: info@benchchem.com

[Contact our Ph.D. Support Team for a compatibility check](#)