

Technical Guide: 3-Chloro-4-ethylphenol in KRAS G12D Inhibitor Synthesis

Author: BenchChem Technical Support Team. **Date:** May 2026

Compound of Interest

Compound Name: 3-Chloro-4-ethylphenol

CAS No.: 1243290-06-3

Cat. No.: B3224977

[Get Quote](#)

Introduction: The Pharmacophore Strategy

The development of potent KRAS G12D inhibitors, such as MRTX1133, relies on identifying molecular fragments that can occupy the dynamic Switch II Pocket (SWII). While early inhibitors utilized bulky naphthyl groups, recent medicinal chemistry campaigns (including WO2022262838A1) have validated substituted phenols like **3-Chloro-4-ethylphenol** as versatile scaffolds.

Why 3-Chloro-4-ethylphenol?

This fragment serves three specific mechanistic functions in the inhibitor architecture:

- **Hydrophobic Fill (4-Ethyl):** The ethyl group provides steric bulk to occupy the lipophilic cleft of the SWII pocket, mimicking the volume of larger fused rings while maintaining a lower molecular weight.
- **Electronic Modulation (3-Chloro):** The chlorine atom at the meta position increases the acidity of the phenol (if free) or modulates the electron density of the ether linkage, influencing the metabolic stability of the aromatic ring against oxidation.

- **Vector Orientation:** When coupled to the heterocyclic core (e.g., pyrido[4,3-d]pyrimidine), the 1,3,4-substitution pattern orients the oxygen atom to engage in critical H-bond networks (often with Glu37 or via water bridges), which is essential for locking KRAS in the GDP-bound state.

Chemical Pathway & Retrosynthesis

The primary application of **3-Chloro-4-ethylphenol** is its conversion into a pinacol boronate ester, which acts as the nucleophilic partner in a Suzuki-Miyaura coupling with the inhibitor's heterocyclic core.

Reaction Scheme Overview

- **Protection (Recommended):** Masking the phenolic hydroxyl to prevent catalyst poisoning.
- **Miyaura Borylation:** Palladium-catalyzed conversion of the aryl chloride to an aryl boronate.
- **Suzuki Coupling:** Attachment to the bicyclic core (e.g., Chloropyrido[4,3-d]pyrimidine).
- **Deprotection:** Revealing the hydroxyl group for final target engagement.



[Click to download full resolution via product page](#)

Figure 1: Synthetic workflow converting **3-Chloro-4-ethylphenol** into the active coupling partner.

Detailed Experimental Protocols

Protocol A: Preparation of the Boronate Intermediate

Objective: Synthesize tert-butyl((5-(4,4,5,5-tetramethyl-1,3,2-dioxaborolan-2-yl)-2-ethylphenoxy)dimethylsilane (or similar protected variant) from **3-Chloro-4-ethylphenol**.

Reagents:

- **3-Chloro-4-ethylphenol** (1.0 eq)[1][2]

- Bis(pinacolato)diboron (

) (1.5 eq)

- (0.05 eq) or

/ XPhos

- Potassium Acetate (KOAc) (3.0 eq)

- Solvent: 1,4-Dioxane (Anhydrous)

Step-by-Step Methodology:

- Protection (Optional but Recommended):

- Dissolve **3-Chloro-4-ethylphenol** in DCM. Add Imidazole (2.0 eq) and TBS-Cl (1.2 eq) at 0°C. Stir at RT for 2 hours.

- Quench with water, extract with DCM, and concentrate. Verify TBS protection via TLC (shift in

, loss of OH stretch in IR).

- Borylation Setup:

- In a glovebox or under Argon stream, charge a reaction flask with the Protected Phenol (1.0 eq),

(1.5 eq), and KOAc (3.0 eq).

- Add 1,4-Dioxane (0.2 M concentration) previously degassed with

for 15 mins.

- Add the Palladium catalyst (

).

- Reaction:
 - Seal the vessel and heat to 90–100°C for 4–12 hours.
 - Monitoring: Monitor by LC-MS. Look for the disappearance of the Aryl-Cl peak and formation of the Boronate mass
 - . Note: Boronates can de-borylate on silica; use neutral alumina or rapid filtration if purifying.
- Workup:
 - Cool to RT. Filter through a pad of Celite to remove Pd black. Rinse with EtOAc.
 - Concentrate the filtrate.
 - Purification: Flash chromatography (Hexane/EtOAc gradient).

Protocol B: Suzuki Coupling to KRAS Core

Objective: Couple the boronate intermediate to a chloropyrido[4,3-d]pyrimidine core (common in MRTX analogs).

Reagents:

- Heterocyclic Core (Aryl Chloride) (1.0 eq)
- Boronate Intermediate (from Protocol A) (1.2 eq)
- Catalyst:

or

(0.05 eq)
- Base:

(2M aq. solution, 3.0 eq)
- Solvent: 1,4-Dioxane/Water (4:1)

Methodology:

- Combine the Core and Boronate in the reaction vial.
- Add solvent and base.[3] Degas by sparging with Argon for 5 minutes.
- Add catalyst.
- Heat to 85°C for 2–6 hours.
- Validation: LC-MS should show the coupled product mass. The "3-Chloro" group from the starting material is now replaced by the C-C bond to the core; the "4-Ethyl" and "Phenol" (protected) remain intact.

Quality Control & Validation Data

To ensure the integrity of the intermediate before expensive coupling steps, verify the following parameters:

QC Parameter	Acceptance Criteria	Method
Purity	> 98% (Area under curve)	HPLC (C18 column, MeCN/H ₂ O + 0.1% FA)
Identity (NMR)	Ethyl triplet (~1.2 ppm) & quartet (~2.6 ppm); Aromatic pattern consistent with 1,3,4-subst.	400 MHz NMR in or
Boronate Stability	Minimal protodeboronation (< 5%)	LC-MS (Check for parent phenol mass)
Residual Metal	< 10 ppm Pd (for final drug substance)	ICP-MS

Structural Logic & SAR Implications

The choice of **3-Chloro-4-ethylphenol** is not arbitrary. In the context of KRAS G12D inhibition, this fragment targets the Switch II hydrophobic sub-pocket.

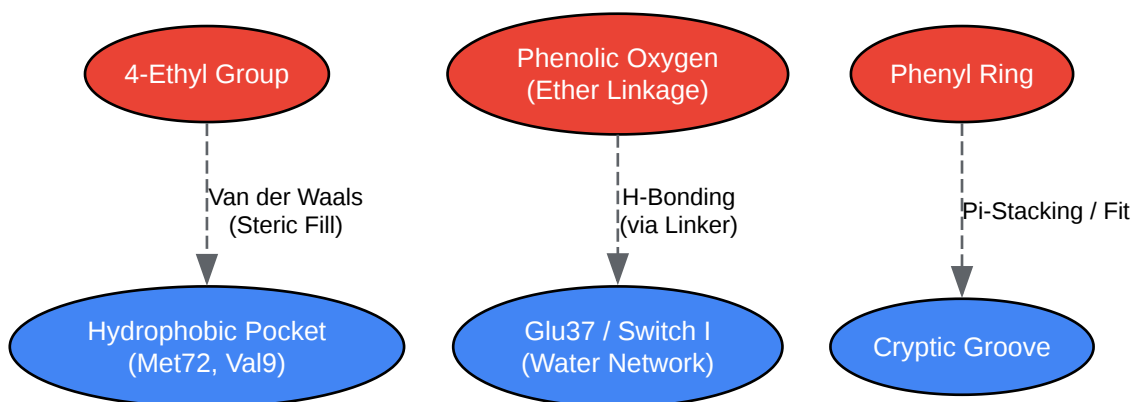

[Click to download full resolution via product page](#)

Figure 2: Interaction map showing how the **3-Chloro-4-ethylphenol** fragment engages KRAS G12D residues.

SAR Insight

- Ethyl vs. Methyl: The ethyl group provides superior occlusion of the pocket compared to a methyl group, potentially increasing residence time ().
- Deuteration Potential: As noted in recent patent literature (WO2022262838A1), the ethyl group is a prime site for deuteration () to suppress benzylic hydroxylation by CYP450 enzymes, thereby improving the pharmacokinetic profile (half-life) of the final inhibitor.

References

- Vertex Pharmaceuticals (Europe) Ltd., et al. (2022). Deuterated compounds useful as KRAS G12D inhibitors. WO2022262838A1.[4][5] [Link](#)
- Wang, X., et al. (2021).[6] Identification of MRTX1133, a Noncovalent, Potent, and Selective KRAS G12D Inhibitor. Journal of Medicinal Chemistry, 65(4), 3123–3133. [Link](#)
- Fell, J. B., et al. (2020).[6] Discovery of MRTX849, a Potent, Selective, and Orally Available Inhibitor of KRAS G12C. Journal of Medicinal Chemistry, 63(13), 6679–6693. [Link](#)

- National Center for Biotechnology Information. (n.d.). PubChem Compound Summary for CID 18419379, **3-Chloro-4-ethylphenol**. [Link\[2\]](#)

Need Custom Synthesis?

BenchChem offers custom synthesis for rare earth carbides and specific isotopic labeling.

Email: info@benchchem.com or [Request Quote Online](#).

Sources

- 1. CN116057059A - [Google Patents \[patents.google.com\]](#)
- 2. 3-Chloro-4-ethylphenol | C₈H₉ClO | CID 18419379 - PubChem [\[pubchem.ncbi.nlm.nih.gov\]](#)
- 3. Organic Syntheses Procedure [\[orgsyn.org\]](#)
- 4. [pubs.acs.org \[pubs.acs.org\]](#)
- 5. Discovery of Potent Deuterated Compounds as Potential KRASG12D Inhibitors in Cancer Therapy - PMC [\[pmc.ncbi.nlm.nih.gov\]](#)
- 6. Structure-Based Design and Synthesis of Potent and Selective KRAS G12D Inhibitors - PMC [\[pmc.ncbi.nlm.nih.gov\]](#)
- To cite this document: BenchChem. [Technical Guide: 3-Chloro-4-ethylphenol in KRAS G12D Inhibitor Synthesis]. BenchChem, [2026]. [Online PDF]. Available at: [\[https://www.benchchem.com/product/b3224977/docs#technical-guide-3-chloro-4-ethylphenol-in-kras-g12d-inhibitor-synthesis\]](https://www.benchchem.com/product/b3224977/docs#technical-guide-3-chloro-4-ethylphenol-in-kras-g12d-inhibitor-synthesis)

Disclaimer & Data Validity:

The information provided in this document is for Research Use Only (RUO) and is strictly not intended for diagnostic or therapeutic procedures. While BenchChem strives to provide accurate protocols, we make no warranties, express or implied, regarding the fitness of this product for every specific experimental setup.

Technical Support: The protocols provided are for reference purposes. Unsure if this reagent suits your experiment?

Need Industrial/Bulk Grade? [Request Custom Synthesis Quote](#)

BenchChem

Our mission is to be the trusted global source of essential and advanced chemicals, empowering scientists and researchers to drive progress in science and industry.

Contact

Address: 3281 E Guasti Rd
Ontario, CA 91761, United States
Phone: (601) 213-4426
Email: info@benchchem.com

[Contact our Ph.D. Support Team for a compatibility check](#)