

Application Note: Biological Screening of 3-Bromoisoxazole-5-carboxamide Libraries

Author: BenchChem Technical Support Team. **Date:** April 2026

Compound of Interest

Compound Name: 3-Bromoisoxazole-5-carboxamide

CAS No.: 1241897-93-7

Cat. No.: B3224888

[Get Quote](#)

Introduction & Scaffold Significance

The **3-bromoisoxazole-5-carboxamide** scaffold represents a privileged chemotype in modern medicinal chemistry. Unlike its non-halogenated counterparts, the inclusion of a bromine atom at the C3 position offers two distinct advantages:

- **Halogen Bonding Capability:** The C3-bromo substituent acts as a sigma-hole donor, capable of forming directed halogen bonds with backbone carbonyls or specific residues (e.g., hinge region methionines in kinases) within a target active site.
- **Synthetic Versatility:** While stable under standard physiological conditions, the C3-bromo group serves as a latent handle for late-stage diversification via Suzuki-Miyaura or Sonogashira couplings, facilitating rapid Structure-Activity Relationship (SAR) expansion.

This guide details the biological screening workflow for libraries based on this core, focusing on enzymatic inhibition (biochemical) and cytotoxicity profiling (phenotypic).

Chemotype Architecture

- Core: Isoxazole ring (aromatic, polar).[1][2]
- C3-Position: Bromine (Hydrophobic/Halogen-bond donor).[3]
- C5-Position: Carboxamide (H-bond donor/acceptor, diversity point).

Library Preparation & Management

Successful screening begins with compound integrity. **3-Bromoisoxazole-5-carboxamides** are generally lipophilic; improper handling can lead to precipitation or "false" inactivity.

Protocol: Compound Solubilization

- Stock Preparation: Dissolve solid library members in 100% DMSO (molecular biology grade) to a concentration of 10 mM.
- Acoustic Quality Control: Centrifuge plates at 1,000 x g for 1 minute to remove air bubbles that interfere with acoustic liquid handlers (e.g., Echo 650).
- Storage: Store at -20°C. Avoid repeated freeze-thaw cycles (limit to <5).
- Working Plate Generation:
 - Dilute 10 mM stocks to 1 mM in 100% DMSO (Intermediate Plate).
 - Further dilute to 50 µM in Assay Buffer (just prior to assay) for a final screening concentration of 1-10 µM.

Critical Caution: Isoxazoles can be susceptible to ring opening under strongly basic conditions (pH > 9.0). Ensure all assay buffers are buffered between pH 7.0 and 8.0 (e.g., HEPES or Tris-HCl).

Workflow Visualization

The following diagram outlines the integrated screening campaign, from library formatting to hit validation.

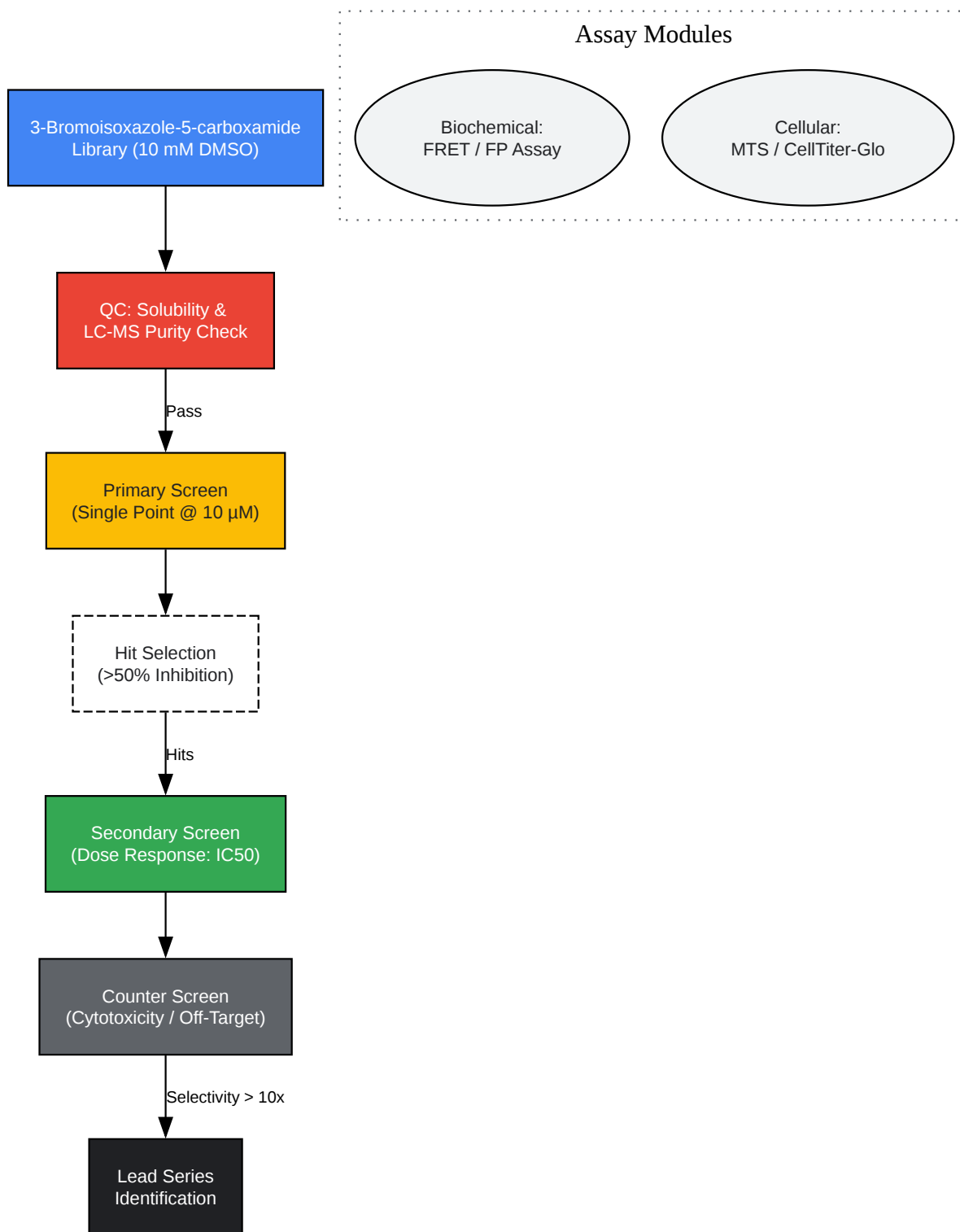

[Click to download full resolution via product page](#)

Caption: Integrated screening workflow for isoxazole-carboxamide libraries, prioritizing hit validation and selectivity profiling.

Protocol A: Biochemical Screen (Enzymatic Inhibition)

This protocol is optimized for screening against Proteases or Kinases, common targets for isoxazole-carboxamides. We utilize a FRET (Fluorescence Resonance Energy Transfer) format to minimize interference from the intrinsic fluorescence of the isoxazole ring.

Reagents

- Enzyme: Recombinant Target (e.g., COX-2, Caspase, or Kinase).
- Substrate: Peptide labeled with Donor (e.g., EDANS) and Quencher (e.g., DABCYL).
- Assay Buffer: 50 mM HEPES (pH 7.4), 10 mM NaCl, 1 mM DTT, 0.01% Triton X-100.
- Positive Control: Known inhibitor (e.g., Celecoxib for COX-2, Staurosporine for Kinases).

Step-by-Step Methodology

- Dispensing:
 - Use an acoustic dispenser to transfer 20 nL of library compounds (10 mM) into black 384-well low-volume plates.
 - Add 20 nL of DMSO to columns 1 and 24 (High/Low controls).
- Enzyme Addition:
 - Dispense 5 μ L of 2x Enzyme Solution into all wells.
 - Incubate for 15 minutes at Room Temperature (RT) to allow compound-enzyme equilibration.
- Substrate Initiation:

- Dispense 5 μ L of 2x Substrate Solution to initiate the reaction.
- Final reaction volume: 10 μ L.
- Final compound concentration: 20 μ M (assuming 10 mM stock).
- Kinetic Read:
 - Measure fluorescence (Ex/Em specific to fluorophore pair) every 2 minutes for 60 minutes on a multimode reader (e.g., PerkinElmer EnVision).
- Data Processing:
 - Calculate the slope (RFU/min) for the linear portion of the curve.
 - Normalize to DMSO controls (0% Inhibition) and No-Enzyme controls (100% Inhibition).

Self-Validating Check: Calculate the Z-prime (Z') factor for the plate. A Z' > 0.5 is required for the data to be accepted.

Protocol B: Phenotypic Screen (Cell Viability)

Isoxazole-carboxamides often exhibit anticancer activity (e.g., against HepG2 or MCF-7 lines). This protocol uses the MTS Assay to assess cytotoxicity, serving either as a primary screen for anticancer agents or a counter-screen for toxicity.

Reagents

- Cell Line: A549 (Lung Carcinoma) or HepG2 (Hepatocellular Carcinoma).
- Media: DMEM + 10% FBS + 1% Pen/Strep.
- Reagent: CellTiter 96® AQueous One Solution (MTS).

Step-by-Step Methodology

- Seeding:
 - Seed cells at 3,000 cells/well in 96-well clear plates (100 μ L volume).

- Incubate for 24 hours at 37°C, 5% CO₂ to allow attachment.
- Compound Treatment:
 - Remove spent media.
 - Add 100 µL of fresh media containing test compounds (diluted to 10 µM, 0.1% DMSO final).
 - Include DMSO vehicle control and 10 µM Doxorubicin (positive killer control).
- Incubation:
 - Incubate for 48 or 72 hours.
- Development:
 - Add 20 µL of MTS reagent directly to each well.
 - Incubate for 1-4 hours at 37°C.
 - Mitochondrial dehydrogenases in viable cells reduce MTS to colored formazan.
- Measurement:
 - Read absorbance at 490 nm.
- Analysis:
 - Calculate % Viability relative to DMSO control.
 - Hit Criteria: Compounds reducing viability by >50% (for anticancer) or <20% (for safety counter-screening).

Data Interpretation & SAR Logic

When analyzing hits from a **3-bromoisoxazole-5-carboxamide** library, look for the following patterns to drive lead optimization:

Quantitative Analysis Table

Parameter	Definition	Acceptance Criteria
IC50	Concentration inhibiting 50% activity	< 1 μ M (Early Lead)
Selectivity Index (SI)	CC50 (Cells) / IC50 (Enzyme)	> 10 (Safety margin)
Hill Slope	Steepness of dose-response curve	0.8 - 1.2 (1.0 = ideal binding)
LE (Ligand Efficiency)	Binding energy per heavy atom	> 0.3 kcal/mol/atom

SAR Visualization (Graphviz)

The following logic tree aids in interpreting Structure-Activity Relationships based on the unique features of this scaffold.

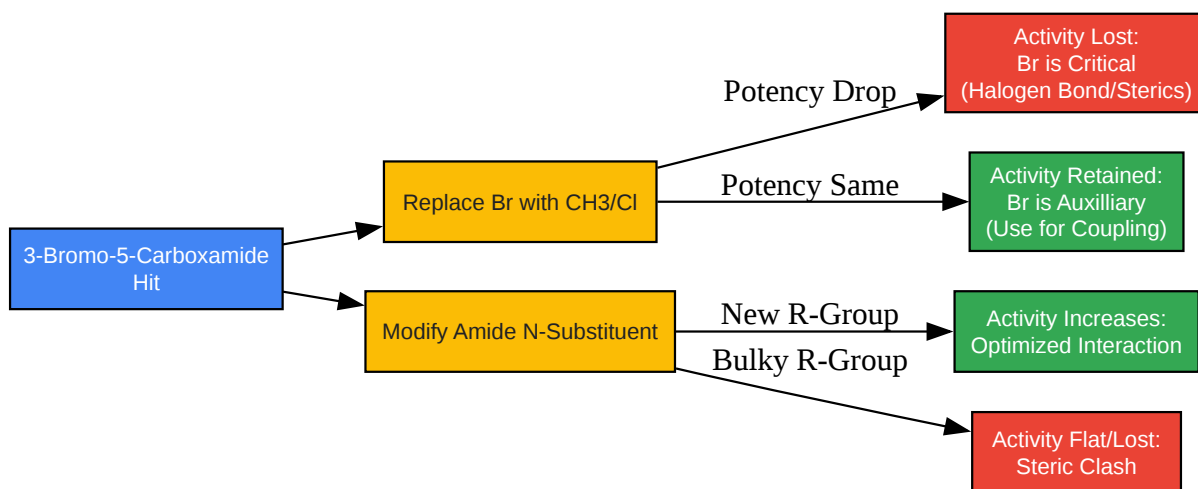

[Click to download full resolution via product page](#)

Caption: Decision tree for validating the functional role of the 3-bromo and 5-carboxamide moieties.

References

- BenchChem Technical Support. (2025).[4] A Technical Guide to the Synthesis of Isoxazole Carboxamide Derivatives. Retrieved from
- National Institutes of Health (NIH). (2022). Molecular docking studies and biological evaluation of isoxazole-carboxamide derivatives as COX inhibitors and antimicrobial agents. PMC9637123. Retrieved from [4]
- University of Parma. (2023). Discovery of a spirocyclic 3-bromo-4,5-dihydroisoxazole covalent inhibitor of hGAPDH. Retrieved from
- MDPI. (2025). Screening-Identified Oxazole-4-Carboxamide KB-2777 Exhibits In Vitro Anti-Coronavirus Activity. Retrieved from
- Royal Society of Chemistry. (2025).[5] Advances in isoxazole chemistry and their role in drug discovery. RSC Advances. Retrieved from

Need Custom Synthesis?

BenchChem offers custom synthesis for rare earth carbides and specific isotopic labeling.

Email: info@benchchem.com or [Request Quote Online](#).

Sources

- [1. researchgate.net](https://www.researchgate.net) [[researchgate.net](https://www.researchgate.net)]
- [2. ajronline.org](https://www.ajronline.org) [[ajronline.org](https://www.ajronline.org)]
- [3. air.unipr.it](https://www.air.unipr.it) [[air.unipr.it](https://www.air.unipr.it)]
- [4. pdf.benchchem.com](https://pdf.benchchem.com) [pdf.benchchem.com]
- [5. pubs.rsc.org](https://pubs.rsc.org) [pubs.rsc.org]
- To cite this document: BenchChem. [Application Note: Biological Screening of 3-Bromoisoxazole-5-carboxamide Libraries]. BenchChem, [2026]. [Online PDF]. Available at: [<https://www.benchchem.com/product/b3224888/docs#application-note-biological-screening-of-3-bromoisoxazole-5-carboxamide-libraries>]

Disclaimer & Data Validity:

The information provided in this document is for Research Use Only (RUO) and is strictly not intended for diagnostic or therapeutic procedures. While BenchChem strives to provide accurate protocols, we make no warranties, express or implied, regarding the fitness of this product for every specific experimental setup.

Technical Support: The protocols provided are for reference purposes. Unsure if this reagent suits your experiment?

Need Industrial/Bulk Grade? [Request Custom Synthesis Quote](#)

BenchChem

Our mission is to be the trusted global source of essential and advanced chemicals, empowering scientists and researchers to drive progress in science and industry.

Contact

Address: 3281 E Guasti Rd
Ontario, CA 91761, United States
Phone: (601) 213-4426
Email: info@benchchem.com

[Contact our Ph.D. Support Team for a compatibility check](#)