

# Technical Application Note: Precision Oxidation of 6-Fluoro-7-azaindole-4-carbaldehyde

**Author:** BenchChem Technical Support Team. **Date:** May 2026

## Compound of Interest

Compound Name: 6-Fluoro-7-azaindole-4-carbaldehyde

CAS No.: 1190310-04-3

Cat. No.: B3218532

[Get Quote](#)

## Executive Summary & Chemical Strategy

The 7-azaindole (1H-pyrrolo[2,3-b]pyridine) scaffold is a "privileged structure" in medicinal chemistry, serving as a bioisostere for indoles and purines in kinase inhibitors (e.g., Vemurafenib, Pexidartinib).[1] The introduction of a fluorine atom at the C6 position increases metabolic stability and modulates pKa, but it also renders the ring system electron-deficient.

Oxidizing the C4-aldehyde to the carboxylic acid presents a specific chemoselectivity challenge:

- **Regioselectivity:** The electron-rich pyrrole ring is susceptible to electrophilic chlorination by byproducts of oxidation.
- **Solubility:** The product is zwitterionic (basic pyridine nitrogen, acidic carboxylic acid), complicating isolation.
- **Stability:** The C-F bond at C6 activates the C4 position towards nucleophilic attack, requiring mild conditions.

Selected Protocol: This guide details a modified Pinnick (Lindgren) Oxidation.[2] This method is chosen for its ability to operate at mild acidic pH (3–5), avoiding the strong basicity of silver oxide methods (which can trigger nucleophilic aromatic substitution of the fluorine) and the harshness of permanganate.

## Reaction Mechanism & Logic

The Pinnick oxidation utilizes sodium chlorite (ngcontent-ng-c1989010908="" \_ngghost-ng-c2193002942="" class="inline ng-star-inserted">

) as the oxidant.[2][3][4][5] The critical mechanistic insight for azaindoles is the management of Hypochlorous Acid (

), a byproduct that chlorinates electron-rich heterocycles.

## Mechanistic Pathway (DOT Diagram)

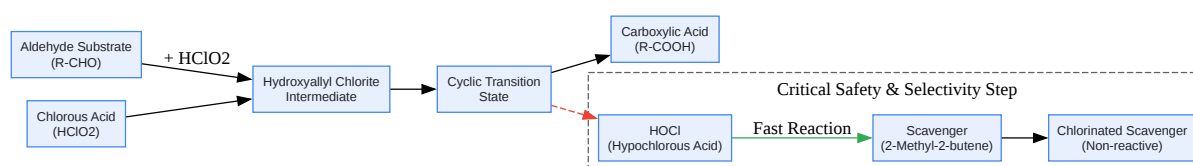

[Click to download full resolution via product page](#)

Figure 1: Mechanistic flow of the Pinnick oxidation highlighting the critical role of the scavenger in preventing side reactions.

## Experimental Protocol: Modified Pinnick Oxidation

### Reagents & Materials

Reagent	Equiv.[1][2][6][7][8]	Role	Notes
6-Fluoro-7-azaindole-4-carbaldehyde	1.0	Substrate	Limiting reagent.
Sodium Chlorite ( )	3.0	Oxidant	Use 80% tech grade; dissolve in water prior to addition.
(Monobasic)	2.0	Buffer	Maintains pH ~3.5 to generate in situ.
2-Methyl-2-butene	10.0	Scavenger	CRITICAL: Sacrificial alkene to trap . Excess is required.
	3:1 v/v	Solvent	suppresses esterification side reactions.

## Step-by-Step Procedure

### Step 1: Reaction Setup

- **Dissolution:** In a round-bottom flask equipped with a magnetic stir bar, dissolve the aldehyde (1.0 mmol) in (15 mL) and 2-methyl-2-butene (10 mmol, ~1.0 mL).
- **Buffer Addition:** Add a solution of (2.0 mmol) in Water (5 mL). The mixture may become biphasic; vigorous stirring is essential.
- **Oxidant Preparation:** Dissolve (3.0 mmol, ~340 mg of 80% purity) in Water (3 mL).
  - **Safety Note:** Do not acidify this solution directly.

## Step 2: Controlled Oxidation

- Addition: Add the solution dropwise to the reaction mixture over 10 minutes at Room Temperature (20–25°C).
  - Observation: The solution may turn pale yellow due to transient formation.
- Monitoring: Stir vigorously for 2–4 hours. Monitor by TLC (5% ) or LCMS.
  - Endpoint: Disappearance of the aldehyde peak ( ) and appearance of the acid peak ( ).

## Step 3: Workup & Isolation (The "Amphoteric" Challenge)

Unlike standard lipophilic acids, 7-azaindole acids are amphoteric. Standard acid/base extraction often leads to yield loss in the aqueous phase.

- Quench: Add saturated aqueous (2 mL) to reduce excess oxidants. Stir for 15 minutes.
- Solvent Removal: Concentrate under reduced pressure to remove and excess 2-methyl-2-butene. The residue will be an aqueous slurry.
- pH Adjustment (Critical):
  - The solution is currently acidic/neutral.
  - Carefully adjust pH to 3–4 using 1N or 1N . This is the calculated isoelectric point (pI) where the zwitterion is least soluble.

- Precipitation:
  - Scenario A (Solid forms): If a white/off-white solid precipitates, cool to 0°C for 30 mins, filter, and wash with cold water.
  - Scenario B (No solid): If the product remains soluble (common with fluorine substitution), extract with 2-MeTHF or EtOAc:THF (3:1). Avoid pure EtOAc as solubility may be poor.
- Drying: Dry organic extracts over \_\_\_\_\_, filter, and concentrate.

## Process Safety & Scale-Up Considerations

### Chlorine Dioxide ( ) Management

Sodium chlorite in acidic media generates chlorine dioxide gas, which is toxic and explosive at high concentrations.

- Ventilation: All operations must occur in a fume hood.
- Exotherm: The reaction is exothermic. On scales >10g, active cooling (ice bath) during addition is mandatory.
- Scavenger: Never omit 2-methyl-2-butene. Without it, the \_\_\_\_\_ byproduct can react with \_\_\_\_\_ to accelerate explosive \_\_\_\_\_ production ("runaway loop").

## Workflow Diagram (DOT)

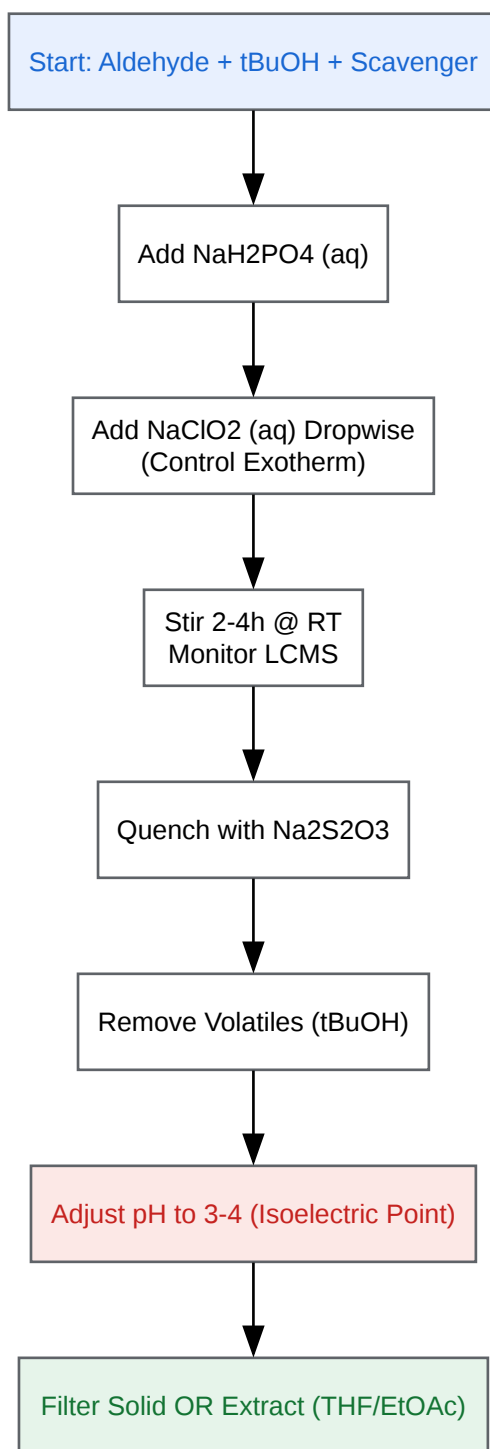

[Click to download full resolution via product page](#)

Figure 2: Operational workflow for the oxidation process.

## Analytical Validation

## Expected Data

Technique	Signal	Interpretation
1H NMR	12.0–13.5 ppm (br s, 1H)	Appearance of Carboxylic Acid proton.
1H NMR	Disappearance of ~10.0 ppm	Loss of Aldehyde proton.
1H NMR	Downfield shift of C5-H	Due to electron-withdrawing COOH group.
19F NMR	-130 to -140 ppm	Fluorine signal (check for splitting changes).
LCMS	M+1 = [Mass of Aldehyde] + 16	Conversion to Acid.

## Troubleshooting Guide

- Problem: Chlorination of the pyrrole ring (M+34 peak observed).
  - Solution: Increase scavenger (2-methyl-2-butene) to 20 equiv. or switch to Resorcinol (1.5 equiv) if alkene is ineffective.
- Problem: Low yield / Product in aqueous phase.
  - Solution: The product is likely forming a water-soluble salt. Saturate the aqueous layer with  
  
(salting out) and use THF for extraction. Do not use basic workup.[3]

## Alternative Protocol: Silver Oxide (Tollens-Type)

Use this ONLY if the Pinnick oxidation fails or causes chlorination.

- Dissolve Aldehyde (1 mmol) in THF/Water (1:1).
- Add

(2.0 equiv) and

(4.0 equiv).

- Stir at RT for 1-2 hours.
- Workup: Filter off black silver solids through Celite. Acidify filtrate to pH 4 to precipitate the product.
  - Risk:[4] The basic conditions ( ) may hydrolyze the C-F bond (nucleophilic aromatic substitution) if heated. Keep strictly at RT or 0°C.

## References

- Pinnick Oxidation (Original Methodology): Bal, B. S.; Childers, W. E.; Pinnick, H. W. "Oxidation of alpha,beta-unsaturated aldehydes." *Tetrahedron*1981, 37, 2091-2096.
- Application to Azaindoles (General Azaindole Synthesis): Song, J. J. et al.[1] "A practical synthesis of 7-azaindole derivatives." *Journal of Organic Chemistry*2002, 67, 3924.
- Lindgren Modification (Chlorite Mechanism): Lindgren, B. O.; Nilsson, T. "Preparation of Carboxylic Acids from Aldehydes Using Sodium Chlorite." [5] *Acta Chemica Scandinavica*1973, 27, 888.
- Silver Oxide Oxidation (Alternative): Thomson, D. W. et al. "Synthesis of Azaindoles." *Journal of Organic Chemistry*2010, 75, 11-15.[9]

### *Need Custom Synthesis?*

*BenchChem offers custom synthesis for rare earth carbides and specific isotopic labeling.*

*Email: [info@benchchem.com](mailto:info@benchchem.com) or [Request Quote Online](#).*

## Sources

- [1. par.nsf.gov](http://1.par.nsf.gov) [[par.nsf.gov](http://par.nsf.gov)]

- [2. Mechanistic investigations on Pinnick oxidation: a density functional theory study - PMC \[pmc.ncbi.nlm.nih.gov\]](#)
- [3. Pinnick oxidation - Wikipedia \[en.wikipedia.org\]](#)
- [4. researchgate.net \[researchgate.net\]](#)
- [5. grokipedia.com \[grokipedia.com\]](#)
- [6. Carboxylic acid synthesis by oxidation of aldehydes \[organic-chemistry.org\]](#)
- [7. pubs.rsc.org \[pubs.rsc.org\]](#)
- [8. pubs.acs.org \[pubs.acs.org\]](#)
- [9. Azaindole synthesis \[organic-chemistry.org\]](#)
- To cite this document: BenchChem. [Technical Application Note: Precision Oxidation of 6-Fluoro-7-azaindole-4-carbaldehyde]. BenchChem, [2026]. [Online PDF]. Available at: [\[https://www.benchchem.com/product/b3218532/docs#technical-application-note-precision-oxidation-of-6-fluoro-7-azaindole-4-carbaldehyde\]](https://www.benchchem.com/product/b3218532/docs#technical-application-note-precision-oxidation-of-6-fluoro-7-azaindole-4-carbaldehyde)

---

### Disclaimer & Data Validity:

The information provided in this document is for Research Use Only (RUO) and is strictly not intended for diagnostic or therapeutic procedures. While BenchChem strives to provide accurate protocols, we make no warranties, express or implied, regarding the fitness of this product for every specific experimental setup.

**Technical Support:** The protocols provided are for reference purposes. Unsure if this reagent suits your experiment?

**Need Industrial/Bulk Grade?** [Request Custom Synthesis Quote](#)

## BenchChem

Our mission is to be the trusted global source of essential and advanced chemicals, empowering scientists and researchers to drive progress in science and industry.

### Contact

Address: 3281 E Guasti Rd

Ontario, CA 91761, United States

Phone: (601) 213-4426

Email: [info@benchchem.com](mailto:info@benchchem.com)

Contact our Ph.D. Support Team for a compatibility check