

# Executive Summary: The Physicochemical Challenge

**Author:** BenchChem Technical Support Team. **Date:** April 2026

## Compound of Interest

Compound Name:	Barbital-d5
CAS No.:	1189694-78-7
Cat. No.:	B3218389

[Get Quote](#)

Achieving baseline separation between **Barbital-d5** and Amobarbital is fundamentally a challenge of managing polarity differences rather than resolving isomers. Unlike the difficult separation of Amobarbital and Pentobarbital (isomers), Barbital and Amobarbital possess significantly different hydrophobicity profiles.

- Barbital (and **Barbital-d5**): Highly polar (LogP ~-0.65). Elutes early, often near the void volume ( ) on standard C18 phases.
- Amobarbital: Lipophilic (LogP ~2.07). Elutes later, showing strong retention on C18.

The Core Issue: If these two analytes are co-eluting or overlapping in your method, it indicates a critical failure in the retention of the polar analyte (**Barbital-d5**). Your method is likely suffering from "void volume elution," where **Barbital-d5** is unretained due to high initial organic solvent strength or inappropriate pH, causing it to merge with the onset of the Amobarbital peak or the matrix front.

## Part 1: The Chemistry of Separation (FAQs)

### Q1: Why are **Barbital-d5** and **Amobarbital** co-eluting when their **LogP** values are so different?

A: Co-elution in this specific pair usually implies zero retention for **Barbital-d5**. If your gradient starts with too high an organic composition (e.g., >10-15% Methanol/Acetonitrile), **Barbital-d5** travels at the solvent front (unretained). If **Amobarbital** is also eluting early due to a steep gradient, they will merge.

- Diagnosis: Check the retention factor ( ) of **Barbital-d5**. If , you are not separating; you are just flushing.

### Q2: How does Mobile Phase pH affect this separation in Negative ESI?

A: Barbiturates are weak acids ( ).

- High pH (> 8.0): Analytes are fully ionized (anionic). This maximizes MS sensitivity in negative mode but destroys retention on C18 columns because the charged molecules repel the stationary phase.
- Low pH (< 4.0): Analytes are neutral. Retention is maximized, but MS sensitivity in negative mode may decrease significantly.
- The "Goldilocks" Zone: Use 5 mM Ammonium Acetate (pH ~6.8). This maintains enough neutrality for **Barbital-d5** to retain on the column while providing sufficient ionization for the MS source [1, 2].

### Q3: Can I use **Barbital-d5** as an Internal Standard for **Amobarbital**?

A:No. This is scientifically unsound. **Barbital-d5** elutes much earlier than Amobarbital. It will not compensate for matrix effects occurring at the Amobarbital retention time.

- Correct Pairing: Use **Barbital-d5** for Barbital and **Amobarbital-d5** (or **Pentobarbital-d5**) for Amobarbital.
- Exception: If you are running a rapid screening method and must separate them to prevent cross-talk or ion suppression from a high-concentration target (Amobarbital) affecting the IS of another (Barbital).

## Part 2: Troubleshooting & Method Optimization

### Scenario A: **Barbital-d5** is eluting in the void (t<sub>0</sub>).

- Root Cause: Initial mobile phase is too strong (too much organic).
- Fix: Reduce initial organic concentration to 5% or 10%. Hold this isocratic condition for 0.5–1.0 minutes to trap the polar **Barbital-d5** at the head of the column.

### Scenario B: **Peak Tailing** is causing overlap.

- Root Cause: Secondary interactions with free silanols on the silica surface.
- Fix:
  - Buffer Strength: Ensure you are using at least 5 mM Ammonium Acetate. Ionic strength masks silanols.
  - Column Choice: Switch to a column with "Polar Endcapping" or a "Polar-Embedded" group (e.g., Waters T3, Agilent SB-Aq, or Phenomenex Polar C18). These are designed to retain polar compounds like Barbital without dewetting [3].

### Scenario C: **Sensitivity is low, forcing me to inject more, which ruins separation.**

- Root Cause: Ion suppression or poor ionization efficiency.

- Fix: Do not add strong acids (Formic Acid) if running in Negative Mode. It suppresses the formation of the

ion. Stick to Ammonium Acetate or extremely low concentrations of Acetic Acid (0.01%).

## Part 3: Validated Experimental Protocol

Objective: Achieve baseline separation (

) of **Barbital-d5** and Amobarbital while maintaining MS sensitivity.

### Chromatographic Conditions

- Column: Agilent Poroshell 120 EC-C18 (2.1 x 100 mm, 2.7  $\mu$ m) or equivalent (e.g., Kinetex C18).
  - Why? Core-shell particles provide high efficiency at lower backpressures, crucial for resolving complex panels.
- Mobile Phase A: 5 mM Ammonium Acetate in Water (pH ~6.8).
- Mobile Phase B: Methanol (MeOH).[1]
  - Note: Methanol often provides better selectivity for barbiturates than Acetonitrile, though Acetonitrile is faster.
- Flow Rate: 0.3 – 0.4 mL/min.
- Column Temp: 40°C.

### Gradient Profile (Linear)

Time (min)	% Mobile Phase B	Event
0.00	10%	Loading: Low organic traps Barbitol-d5.
1.00	10%	Isocratic Hold: Ensures Barbitol-d5 is retained.
6.00	60%	Elution: Gradual ramp elutes Amobarbital.
7.00	95%	Wash: Cleans column of lipophilic matrix.
8.50	95%	Hold: Wash complete.
8.60	10%	Re-equilibration: Critical for reproducibility.
11.00	10%	Ready: Next injection.

## Mass Spectrometry Parameters (Negative ESI)

- Source: ESI Negative Mode.
- Capillary Voltage: 2500–3000 V (Lower than Pos mode to prevent discharge).
- MRM Transitions:
  - **Barbitol-d5:**  
  
(Quant)
  - Amobarbital:  
  
(Quant),  
  
(Qual) [1, 4].

## Part 4: Visualizing the Workflow

## Diagram 1: Troubleshooting Logic for Barbiturate Co-elution

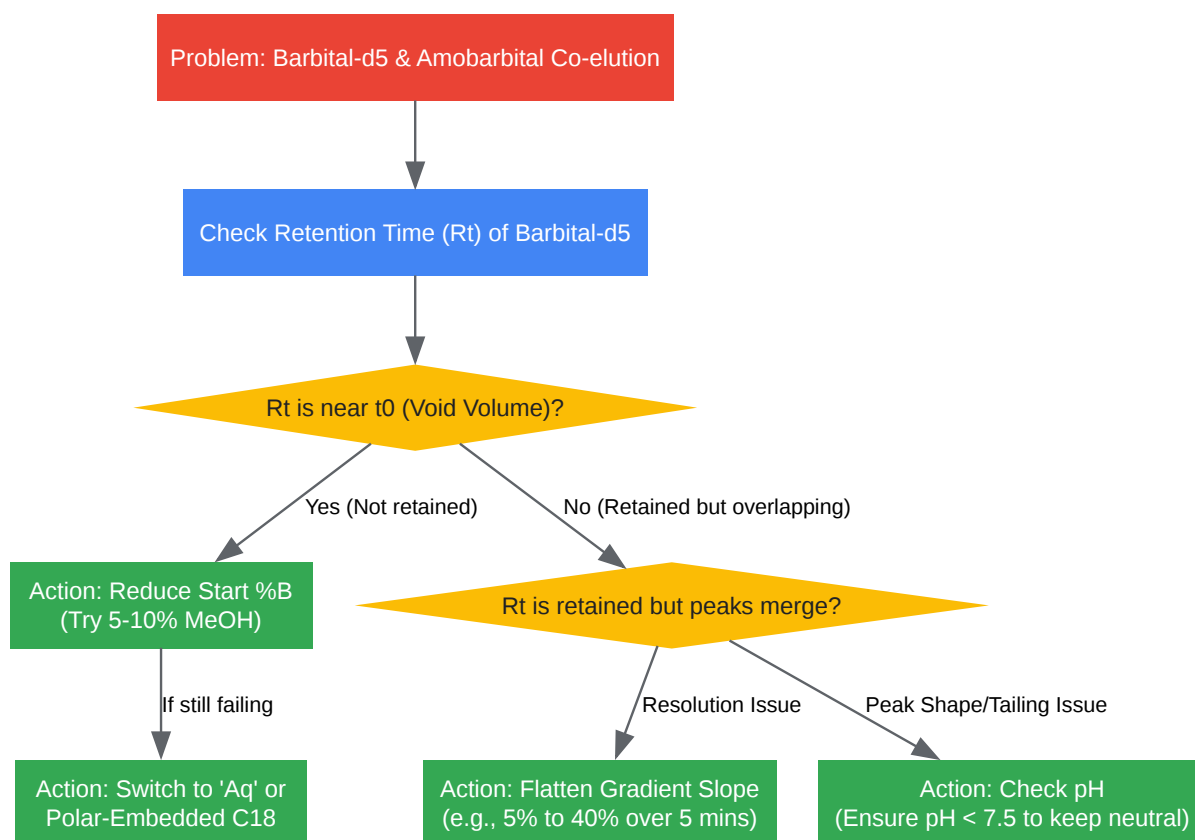

[Click to download full resolution via product page](#)

Caption: Step-by-step diagnostic flow to resolve co-elution by addressing retention failures (void volume) versus selectivity failures (gradient slope).

## Diagram 2: Column Selection Strategy for Barbiturates

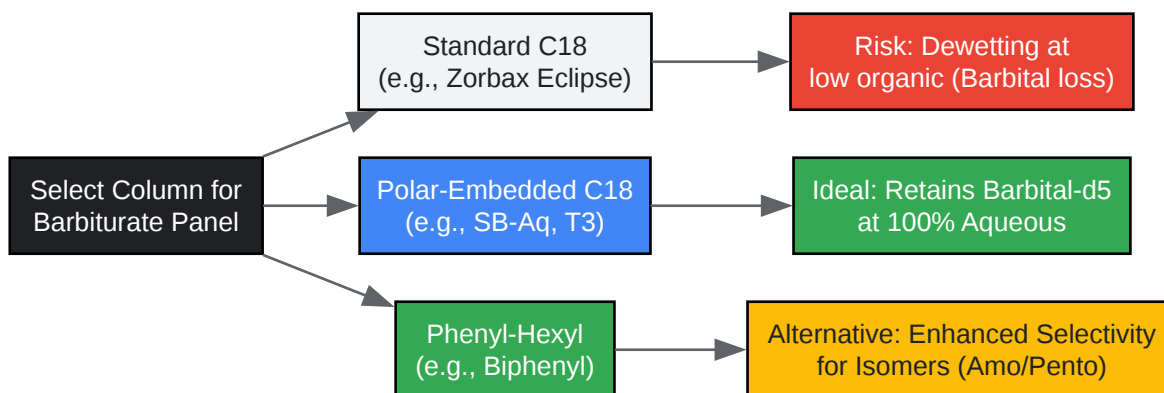

[Click to download full resolution via product page](#)

Caption: Decision matrix for stationary phase selection. Polar-embedded phases are recommended to ensure retention of **Barbital-d5**.

## References

- Agilent Technologies. (2020). A Fast Analytical LC/MS/MS Method for the Simultaneous Analysis of Barbiturates and 11-nor-9-carboxy- $\Delta^9$ -tetrahydrocannabinol. Application Note 5994-1857EN.
- Waters Corporation. (2014). Quantitative Analysis of Barbiturates in Urine Using UPLC-MS/MS. Application Note 720004068EN.
- Restek Corporation. (2021). Simultaneous Analysis of Alcohol Metabolites and Barbiturates without Enzymatic Hydrolysis by LC-MS/MS.
- National Center for Biotechnology Information. (2024). PubChem Compound Summary for CID 2294, Barbital.

### Need Custom Synthesis?

BenchChem offers custom synthesis for rare earth carbides and specific isotopic labeling.

Email: [info@benchchem.com](mailto:info@benchchem.com) or [Request Quote Online](#).

## Sources

- [1. dfs.virginia.gov \[dfs.virginia.gov\]](https://dfs.virginia.gov)
- To cite this document: BenchChem. [Executive Summary: The Physicochemical Challenge]. BenchChem, [2026]. [Online PDF]. Available at: [\[https://www.benchchem.com/product/b3218389/docs#executive-summary-the-physicochemical-challenge\]](https://www.benchchem.com/product/b3218389/docs#executive-summary-the-physicochemical-challenge)

---

### Disclaimer & Data Validity:

The information provided in this document is for Research Use Only (RUO) and is strictly not intended for diagnostic or therapeutic procedures. While BenchChem strives to provide accurate protocols, we make no warranties, express or implied, regarding the fitness of this product for every specific experimental setup.

**Technical Support:** The protocols provided are for reference purposes. Unsure if this reagent suits your experiment?

**Need Industrial/Bulk Grade?** [Request Custom Synthesis Quote](#)

## BenchChem

Our mission is to be the trusted global source of essential and advanced chemicals, empowering scientists and researchers to drive progress in science and industry.

### Contact

Address: 3281 E Guasti Rd  
Ontario, CA 91761, United States  
Phone: (601) 213-4426  
Email: [info@benchchem.com](mailto:info@benchchem.com)

[Contact our Ph.D. Support Team for a compatibility check](#)