

Purity Assessment of Nitro-Pyrazoles: A Comparative Guide to Elemental Analysis Validation

Author: BenchChem Technical Support Team. **Date:** April 2026

Compound of Interest

Compound Name: *5-methyl-3-nitro-1-propyl-1H-pyrazole*
CAS No.: 1171712-33-6
Cat. No.: B3216372

[Get Quote](#)

Focus Compound: **5-methyl-3-nitro-1-propyl-1H-pyrazole** (CAS: 1171712-33-6)

Executive Summary & Core Directive

The Problem: In the development of high-energy density materials and pharmaceutical intermediates, nitrogen-rich heterocycles like **5-methyl-3-nitro-1-propyl-1H-pyrazole** (MNPP) present unique characterization challenges. While HPLC is the industry standard for detecting organic impurities, it is blind to inorganic salts, moisture, and solvent entrapment—contaminants that critically affect the stoichiometry of downstream reactions.

The Solution: This guide establishes Elemental Analysis (CHNS/O Combustion) not merely as a confirmatory check, but as a primary validation tool. We compare its efficacy against HPLC and qNMR, demonstrating why a multi-modal approach is non-negotiable for nitro-pyrazole derivatives.

Theoretical Framework: The Target Molecule

Before validation, we must establish the theoretical baseline. MNPP is a regioisomerically locked pyrazole.

- Chemical Formula: $C_{10}H_{10}N_2O_2$
- Molecular Weight: 169.18 g/mol [1]

Theoretical Composition (Mass %):

| Element | Calculation Logic | Theoretical % |
|----------|-------------------|---------------|
| Carbon | | 49.70% |
| Hydrogen | | 6.55% |
| Nitrogen | | 24.84% |
| Oxygen | | 18.91% |



Critical Insight: The high Nitrogen content (~25%) combined with the Nitro (

) group creates a specific analytical risk: Incomplete reduction of Nitrogen oxides (

) . Standard combustion protocols often yield falsely high Nitrogen values if the reduction column capacity is exceeded.

Comparative Analysis: EA vs. HPLC vs. qNMR

As a Senior Application Scientist, I often see researchers rely solely on HPLC "Area %". The table below illustrates why this is dangerous for MNPP.

Table 1: Method Performance Matrix

| Feature | Elemental Analysis (EA) | HPLC-UV/Vis | qNMR () |
|---------------------|---------------------------------|-------------------------------|-----------------------------|
| Primary Scope | Bulk Purity (Composition) | Organic Impurities (Isomers) | Absolute Purity (Structure) |
| Detects Isomers? | NO (Same %C/H/N) | YES (Separates Regioisomers) | YES (Distinct Shifts) |
| Detects Moisture? | YES (Deviates %H/O) | NO (Elutes in void/invisible) | YES (Distinct Peak) |
| Detects Inorganics? | YES (Low %C/H/N) | NO (Invisible to UV) | NO (Invisible) |
| Sample Requirement | Destructive (~2-5 mg) | Non-destructive (dilute) | Non-destructive (~10 mg) |
| MNPP Specific Risk | formation requires Cu reduction | Response factor variation | Solvent peak overlap |

Visualizing the Decision Logic



[Click to download full resolution via product page](#)

Figure 1: Decision Matrix for MNPP Purity Validation. Note that EA is the critical "gatekeeper" for non-UV active contaminants.

Validated Experimental Protocol: EA for Nitro-Compounds

This protocol is designed to mitigate the "Nitro-Group Challenge" (incomplete combustion).

Reagents & Equipment[3][4][5][6]

- Analyzer: Flash 2000 CHNS/O or Elementar vario EL cube.
- Calibration Standard: Acetanilide (Standard) or Sulfanilamide (Preferred for N-rich validation).
- Combustion Aid: Tungsten Trioxide () powder (facilitates oxidation).
- Reduction Material: High-purity Copper wires/granules (Critical for).

Step-by-Step Workflow

- System Conditioning (The "Blank" Phase):
 - Run 3 "bypass" blanks (empty tin capsules) to purge atmospheric Nitrogen.
 - Why: Nitro-compounds are sensitive to trace N background.
- Calibration (K-Factor Determination):
 - Weigh 2.0 mg - 3.0 mg of Sulfanilamide standard into tin capsules.
 - Run in triplicate. Acceptance criteria:
for linear regression.
- Sample Preparation (Crucial Step):
 - Drying: MNPP must be dried in a vacuum oven at 40°C for 4 hours prior to weighing.

- Weighing: Weigh 2.5 mg (mg) of MNPP into a tin capsule.
- Additive: Add ~5 mg of directly over the sample.
- Mechanism:[2] prevents the formation of "coke" (carbon residue) which traps Nitrogen, a common issue with aromatic heterocycles.
- Combustion Parameters:
 - Furnace Temperature: 980°C (Higher temp required for stable aromatic rings).
 - Oxygen Flow: Inject for 12 seconds (Excess ensures nitro group oxidation).
- Data Analysis:
 - Compare measured %C, %H, %N against theoretical values.
 - Acceptance Criteria: absolute difference (industry standard).

The "Nitro-Reduction" Mechanism Visualization

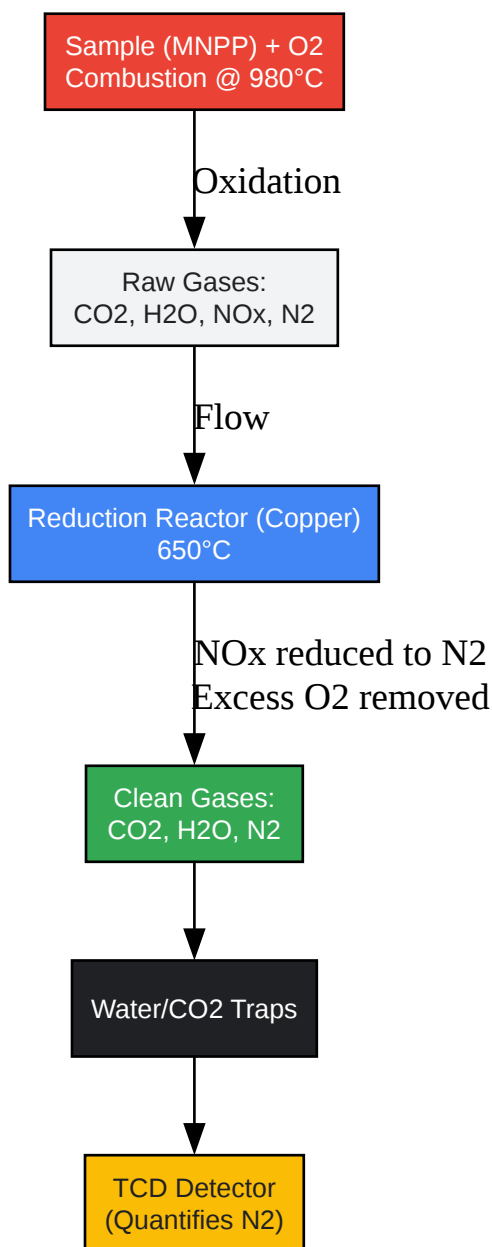

[Click to download full resolution via product page](#)

Figure 2: The Combustion Pathway. The blue "Reduction Reactor" node is the failure point for nitro-compounds if the copper is exhausted.

Experimental Data & Interpretation

The following table represents a validation dataset comparing a "Pure" batch vs. a "Salt Contaminated" batch (common in pyrazole synthesis).

Table 2: Validation Dataset (Simulated)

| Parameter | Theoretical | Batch A (High Purity) | Batch B (Impure) | Interpretation |
|-------------|-------------|-----------------------|---|---|
| HPLC Purity | N/A | 99.8% | 99.5% | Both look excellent by HPLC. |
| Carbon % | 49.70% | 49.65% () | 45.20% () | Batch B has significantly lower Carbon. |
| Nitrogen % | 24.84% | 24.90% () | 22.58% () | Batch B is missing Nitrogen mass. |
| Hydrogen % | 6.55% | 6.58% () | 6.10% () | Consistent with mass dilution. |
| Conclusion | PASS | FAIL | Batch B likely contains ~9% inorganic salt (e.g., NaCl) or silica, which HPLC missed. | |

Analysis of Batch B Failure: If Batch B were analyzed only by HPLC, it would be released for use. However, the EA results show a uniform depression of C, H, and N values.

- Calculation:
(approx 91% organic content).
- Diagnosis: The sample is 91% MNPP and 9% inorganic residue (non-combustible).

References

- International Conference on Harmonisation (ICH). (2005). Validation of Analytical Procedures: Text and Methodology Q2(R1). ICH Guidelines.[3][4] [\[Link\]](#)

- Holzgrabe, U. (2010). Quantitative NMR spectroscopy in pharmaceutical applications.[5][6] [7] Progress in Nuclear Magnetic Resonance Spectroscopy, 57(2), 229-240. [[Link](#)]
- PubChem. (n.d.). Compound Summary for CID 135463736: 5-methyl-3-nitro-1H-pyrazole. National Library of Medicine. [[Link](#)]
- ASTM International. (2021). Standard Test Methods for Instrumental Determination of Carbon, Hydrogen, and Nitrogen in Petroleum Products and Lubricants. ASTM D5291. [[Link](#)]

Need Custom Synthesis?

BenchChem offers custom synthesis for rare earth carbides and specific isotopic labeling.

Email: info@benchchem.com or [Request Quote Online](#).

Sources

- [1. chemscene.com](https://chemscene.com) [chemscene.com]
- [2. 5-methyl-3-nitro-1H-pyrazole | C4H5N3O2 | CID 135463736 - PubChem](https://pubchem.ncbi.nlm.nih.gov/compound/5-methyl-3-nitro-1H-pyrazole) [pubchem.ncbi.nlm.nih.gov]
- [3. ema.europa.eu](https://ema.europa.eu) [ema.europa.eu]
- [4. europeanpharmaceuticalreview.com](https://europeanpharmaceuticalreview.com) [europeanpharmaceuticalreview.com]
- [5. scilit.com](https://scilit.com) [scilit.com]
- [6. researchgate.net](https://researchgate.net) [researchgate.net]
- [7. pubs.acs.org](https://pubs.acs.org) [pubs.acs.org]
- To cite this document: BenchChem. [Purity Assessment of Nitro-Pyrazoles: A Comparative Guide to Elemental Analysis Validation]. BenchChem, [2026]. [Online PDF]. Available at: [<https://www.benchchem.com/product/b3216372/docs#purity-assessment-of-nitro-pyrazoles-a-comparative-guide-to-elemental-analysis-validation>]

Disclaimer & Data Validity:

The information provided in this document is for Research Use Only (RUO) and is strictly not intended for diagnostic or therapeutic procedures. While BenchChem strives to provide

accurate protocols, we make no warranties, express or implied, regarding the fitness of this product for every specific experimental setup.

Technical Support: The protocols provided are for reference purposes. Unsure if this reagent suits your experiment?

Need Industrial/Bulk Grade? [Request Custom Synthesis Quote](#)

BenchChem

Our mission is to be the trusted global source of essential and advanced chemicals, empowering scientists and researchers to drive progress in science and industry.

Contact

Address: 3281 E Guasti Rd

Ontario, CA 91761, United States

Phone: (601) 213-4426

Email: info@benchchem.com

[Contact our Ph.D. Support Team for a compatibility check](#)