

Navigating the Maze: A Comparative Guide to Mass Spectrometry Fragmentation Patterns of Dibromonaphthols

Author: BenchChem Technical Support Team. **Date:** April 2026

Compound of Interest

Compound Name: 6,7-Dibromonaphthalen-1-ol

CAS No.: 117157-37-6

Cat. No.: B3216332

[Get Quote](#)

For researchers, scientists, and professionals in drug development, the precise structural elucidation of halogenated compounds is a critical step in ensuring the safety and efficacy of new chemical entities. Dibromonaphthols, a class of compounds with potential applications in synthesis and as intermediates, present a unique analytical challenge due to the influence of their bromine and hydroxyl substituents on mass spectrometric fragmentation. This guide provides an in-depth comparison of the expected fragmentation patterns of dibromonaphthols, supported by established principles of mass spectrometry and data from related compounds. We will explore how different ionization techniques and isomeric positions can influence the resulting mass spectra, offering a predictive framework for their identification.

The Fundamentals of Fragmentation in Dibromonaphthols

The fragmentation of an organic molecule in a mass spectrometer is not a random process. It is governed by the stability of the resulting ions and neutral losses. For dibromonaphthols, the

key structural features that dictate fragmentation are the stable naphthalene core, the electron-withdrawing bromine atoms, and the electron-donating hydroxyl group.

Under electron ionization (EI), the initial event is the removal of an electron to form a molecular ion ($M^{+\bullet}$). The stability of this molecular ion is relatively high due to the aromatic system. However, the high energy of EI (typically 70 eV) provides sufficient energy for subsequent fragmentation. The fragmentation pathways are influenced by the relative stability of the resulting carbocations and radical species.

Predicted Fragmentation Pathways of Dibromonaphthols

While specific, published fragmentation data for all dibromonaphthol isomers is limited, we can predict the major fragmentation pathways based on the well-documented behavior of brominated aromatic compounds and phenols. The primary fragmentation events are expected to be the loss of bromine atoms and the elimination of carbon monoxide (CO) from the hydroxyl group.

A key characteristic of compounds containing bromine is the isotopic pattern of the molecular ion and its fragments. Bromine has two stable isotopes, ^{79}Br and ^{81}Br , in nearly a 1:1 ratio. This results in a characteristic M, M+2, and M+4 pattern for ions containing two bromine atoms, with relative intensities of approximately 1:2:1.

The primary fragmentation steps are predicted as follows:

- **Loss of a Bromine Atom:** The initial fragmentation is most likely the cleavage of a C-Br bond to lose a bromine radical ($\bullet\text{Br}$), forming a $[\text{M}-\text{Br}]^+$ ion. This is a common pathway for halogenated aromatic compounds.
- **Sequential Loss of the Second Bromine Atom:** The $[\text{M}-\text{Br}]^+$ ion can then lose the second bromine radical to form a $[\text{M}-2\text{Br}]^+$ ion.
- **Loss of Carbon Monoxide:** Following the loss of one or both bromine atoms, the naphthol structure can undergo the characteristic loss of carbon monoxide (CO) from the phenolic ring. This results in the formation of a five-membered ring, a common rearrangement for phenols.

- Loss of HBr: Another possible fragmentation pathway is the elimination of a neutral hydrogen bromide (HBr) molecule.

The following diagram illustrates the predicted fragmentation pathway for a generic dibromonaphthol:

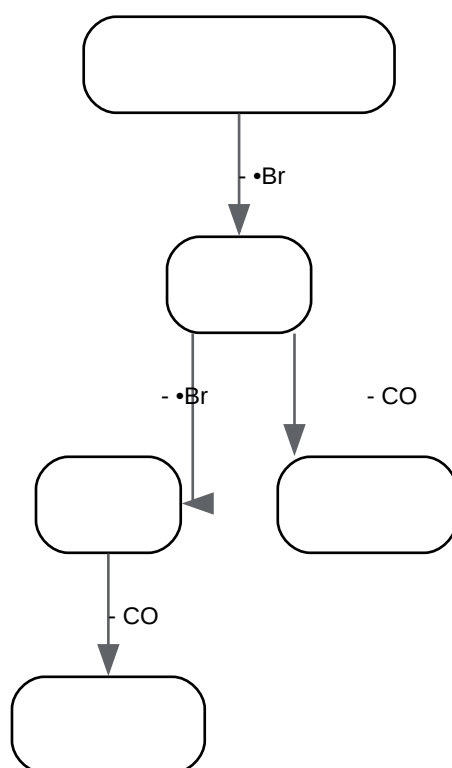

[Click to download full resolution via product page](#)

Caption: Predicted electron ionization fragmentation pathway for a dibromonaphthol.

Isomeric Differentiation: A Tale of Two Positions

The position of the bromine and hydroxyl groups on the naphthalene ring is expected to have a subtle but significant impact on the relative abundances of the fragment ions. While the primary fragmentation pathways will likely be the same for all isomers, the stability of the intermediate ions can vary, leading to different peak intensities in the mass spectrum.

For instance, the stability of the $[M-\text{Br}]^+$ ion will be influenced by the position of the remaining bromine and hydroxyl groups. A more stable carbocation will lead to a more abundant fragment ion. Tandem mass spectrometry (MS/MS) would be a powerful tool to further probe these

differences. In an MS/MS experiment, the $[M-Br]^+$ ion of a specific isomer could be isolated and subjected to collision-induced dissociation (CID) to generate a secondary fragmentation pattern that may be unique to that isomer.

Comparative Data Summary

The following table summarizes the predicted key ions and their isotopic patterns for a generic dibromonaphthol. The exact m/z values will depend on the specific isomer.

Ion	Description	Isotopic Pattern
$M^{+\bullet}$	Molecular Ion	M, M+2, M+4 (1:2:1 ratio)
$[M-Br]^+$	Loss of one bromine atom	M-Br, (M-Br)+2 (1:1 ratio)
$[M-2Br]^+$	Loss of two bromine atoms	Single peak
$[M-Br-CO]^+$	Loss of one bromine and CO	M-Br-CO, (M-Br-CO)+2 (1:1 ratio)
$[M-HBr]^+\bullet$	Loss of hydrogen bromide	M-HBr, (M-HBr)+2 (1:1 ratio)

Experimental Protocols

For researchers aiming to analyze dibromonaphthols, Gas Chromatography-Mass Spectrometry (GC-MS) with electron ionization is the recommended technique for initial identification due to its ability to separate isomers and produce reproducible fragmentation patterns. For more detailed structural analysis and isomeric differentiation, Liquid Chromatography-Tandem Mass Spectrometry (LC-MS/MS) with a soft ionization technique like Electrospray Ionization (ESI) followed by CID would be optimal.

GC-MS with Electron Ionization (EI) Protocol

This protocol provides a general framework for the analysis of dibromonaphthols. Optimization of parameters will be necessary for specific isomers and instrumentation.

- **Sample Preparation:** Dissolve the dibromonaphthol standard or sample in a suitable volatile solvent (e.g., dichloromethane, hexane) to a concentration of approximately 1-10 $\mu\text{g/mL}$.

- GC Separation:
 - Column: A non-polar or medium-polarity capillary column (e.g., DB-5ms, HP-5ms) is recommended.
 - Injection: 1 μ L splitless injection at 250°C.
 - Oven Program: Start at 100°C, hold for 2 minutes, ramp to 280°C at 10°C/min, and hold for 5 minutes.
 - Carrier Gas: Helium at a constant flow rate of 1 mL/min.
- MS Detection:
 - Ionization Mode: Electron Ionization (EI) at 70 eV.
 - Mass Analyzer: Quadrupole or Time-of-Flight (TOF).
 - Scan Range: m/z 50-500.
 - Source Temperature: 230°C.
 - Quadrupole Temperature: 150°C.

The following diagram illustrates the GC-MS workflow:

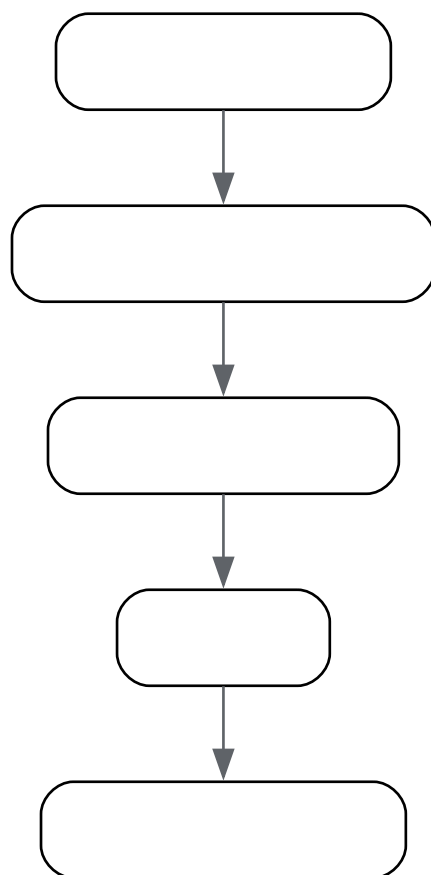

[Click to download full resolution via product page](#)

Caption: General workflow for GC-MS analysis of dibromonaphthols.

Conclusion

The mass spectrometric fragmentation of dibromonaphthols is predicted to be dominated by the sequential loss of bromine atoms and the elimination of carbon monoxide. The characteristic isotopic signature of bromine provides a clear marker for the presence of these compounds. While the fundamental fragmentation pathways are expected to be consistent across different isomers, the relative intensities of the fragment ions can offer clues for their differentiation, particularly when analyzed by tandem mass spectrometry. The experimental protocols outlined in this guide provide a solid starting point for the analysis of these challenging but important molecules, enabling researchers to navigate the complexities of their structural elucidation with greater confidence.

References

- Analysis of Bromophenols in Various Aqueous Samples Using Solid Phase Extraction Followed by HPLC-MS/MS. [\[Link\]](#)
- Use of Electron Capture Negative Ion Mass Spectra to Establish the Identities of Polybrominated Diphenyl Ether Flame Retardants and Their Degradation Products. [\[Link\]](#)
- Polybromination of naphthalene using bromine over a montmorillonite clay and regioselective synthesis of 2,6-dibromonaphthalene. [\[Link\]](#)
- Fragmentation (mass spectrometry) - Wikipedia. [\[Link\]](#)
- Polybromination of naphthalene using bromine over a montmorillonite clay and regioselective synthesis of 2,6-dibromonaphthalene. [\[Link\]](#)
- Mass Spectrometry (MS) Fragmentation Patterns (HL) (DP IB Chemistry): Revision Note. [\[Link\]](#)
- 12.3: Mass Spectrometry of Some Common Functional Groups - Chemistry LibreTexts. [\[Link\]](#)
- GCMS 3 Fragmentation Patterns - YouTube. [\[Link\]](#)
- To cite this document: BenchChem. [\[Navigating the Maze: A Comparative Guide to Mass Spectrometry Fragmentation Patterns of Dibromonaphthols\]](#). BenchChem, [2026]. [\[Online PDF\]](#). Available at: [\[https://www.benchchem.com/product/b3216332/docs#navigating-the-maze-a-comparative-guide-to-mass-spectrometry-fragmentation-patterns-of-dibromonaphthols\]](https://www.benchchem.com/product/b3216332/docs#navigating-the-maze-a-comparative-guide-to-mass-spectrometry-fragmentation-patterns-of-dibromonaphthols)

Disclaimer & Data Validity:

The information provided in this document is for Research Use Only (RUO) and is strictly not intended for diagnostic or therapeutic procedures. While BenchChem strives to provide accurate protocols, we make no warranties, express or implied, regarding the fitness of this product for every specific experimental setup.

Technical Support: The protocols provided are for reference purposes. Unsure if this reagent suits your experiment?

Need Industrial/Bulk Grade? [Request Custom Synthesis Quote](#)

BenchChem

Our mission is to be the trusted global source of essential and advanced chemicals, empowering scientists and researchers to drive progress in science and industry.

Contact

Address: 3281 E Guasti Rd

Ontario, CA 91761, United States

Phone: (601) 213-4426

Email: info@benchchem.com

[Contact our Ph.D. Support Team for a compatibility check](#)