

Comprehensive Guide: FTIR Spectral Analysis of 3-Amino-N-Methoxy-N-Methylbenzamide

Author: BenchChem Technical Support Team. **Date:** April 2026

Compound of Interest

Compound Name: *3-amino-N-methoxy-N-methylbenzamide*

CAS No.: *1156151-22-2*

Cat. No.: *B3214960*

[Get Quote](#)

Executive Summary & Molecule Profile

3-amino-N-methoxy-N-methylbenzamide is a critical bifunctional intermediate in medicinal chemistry. It combines an aniline moiety (position 3) with a Weinreb amide functionality (position 1). This molecule is frequently used as a stable precursor for synthesizing aryl ketones via nucleophilic addition (e.g., Grignard reactions) while retaining the amino group for further derivatization.

This guide provides a technical breakdown of its Fourier Transform Infrared (FTIR) analysis, focusing on quality control (QC) and reaction monitoring. It compares FTIR performance against alternative analytical techniques and details the specific spectral "fingerprint" required for positive identification.

Target Molecule Specifications

Property	Detail
IUPAC Name	3-amino-N-methoxy-N-methylbenzamide
Functional Groups	Primary Amine (-NH ₂), Weinreb Amide (-CON(OMe)Me), Aromatic Ring (1,3-substituted)
Physical State	Viscous oil or low-melting solid (dependent on purity/polymorph)
Key Application	Synthesis of meta-substituted aryl ketones; drug linker chemistry

Spectral Prediction & Analysis (The "Fingerprint")[1]

Positive identification requires verifying three distinct spectral zones.[1] The coexistence of the Weinreb amide and the primary amine creates a unique spectral signature distinguishable from common precursors (e.g., nitro-compounds) or hydrolysis byproducts (e.g., carboxylic acids).

Zone A: High-Frequency Region (3500 – 2800 cm⁻¹)

- Primary Amine (-NH₂): Look for a "doublet" pattern representing the N-H stretching vibrations.[2]
 - Asymmetric Stretch: ~3450 cm⁻¹
 - Symmetric Stretch: ~3350 cm⁻¹
- Aromatic C-H: Weak, sharp peaks just above 3000 cm⁻¹ (3010–3080 cm⁻¹).
- Aliphatic C-H (Weinreb Methyls): Distinct peaks below 3000 cm⁻¹.
 - N-Me / O-Me Stretches: 2930–2960 cm⁻¹.
 - O-CH₃ (Fermi Resonance): Often appears as a sharp shoulder ~2830 cm⁻¹, specific to methoxy groups.[3]

Zone B: The Double Bond Region (1700 – 1500 cm⁻¹)

- Weinreb Amide C=O (Amide I): The carbonyl stretch in Weinreb amides is typically found at 1630–1660 cm^{-1} . It appears at a slightly lower frequency than typical esters or ketones due to the electron-donating nature of the methoxy-amine nitrogen.
- Amine N-H Bend (Scissoring): A medium-intensity band at $\sim 1620 \text{ cm}^{-1}$. Note: This often overlaps with the Amide I band, resulting in a broadened or split peak structure.
- Aromatic Ring Stretches: Sharp, variable bands at 1580–1600 cm^{-1} and 1480–1500 cm^{-1} .

Zone C: Fingerprint & Substituents (1400 – 600 cm^{-1})

- C-N Stretch (Ar-NH₂): Strong band at 1250–1335 cm^{-1} .
- N-O-C Stretch (Weinreb Specific): A critical identifier for the Weinreb moiety. Look for a distinct band in the 950–1050 cm^{-1} range (typically $\sim 1000 \text{ cm}^{-1}$), corresponding to the N-O stretch.
- Meta-Substitution Pattern: 1,3-disubstituted benzene rings show two key bending vibrations:
 - Ring Bend: $\sim 690 \text{ cm}^{-1}$
 - C-H Wag: $\sim 750\text{--}810 \text{ cm}^{-1}$ (often strong).

Summary Table: Characteristic Bands

Functional Group	Vibration Mode	Frequency (cm ⁻¹)	Intensity
Primary Amine	N-H Stretch (Asym/Sym)	3450 / 3350	Medium (Doublet)
Weinreb Amide	C=O[4] Stretch (Amide I)	1635–1660	Strong
Primary Amine	N-H Bend (Scissoring)	1615–1625	Medium
Aromatic Ring	C=C Ring Stretch	1580–1600	Variable
Aromatic Amine	C-N Stretch	1260–1310	Strong
Weinreb Linker	N-O Stretch	980–1020	Medium/Strong
Meta-Substitution	C-H Out-of-Plane Bend	750–800	Strong

Comparative Performance Guide

This section compares FTIR against alternative methods for specific analytical scenarios involving **3-amino-N-methoxy-N-methylbenzamide**.

Scenario 1: Synthesis Monitoring (Nitro Reduction)

Context: Converting 3-nitro-N-methoxy-N-methylbenzamide to the target 3-amino compound.

Feature	FTIR (Recommended)	HPLC-UV	1H NMR
Speed	< 2 mins (At-line)	15–30 mins (Method dependent)	15–60 mins (Prep + Scan)
Key Indicator	Disappearance of NO ₂ (1530/1350 cm ⁻¹) Appearance of NH ₂ (3300-3500 cm ⁻¹)	Shift in Retention Time	Chemical shift of aromatic protons
Sample Prep	None (ATR)	Dilution required	Dissolution in deuterated solvent
Cost per Run	Low	Medium (Solvents/Columns)	High

Verdict: FTIR is the superior choice for real-time reaction monitoring. The disappearance of the symmetric and asymmetric NO₂ stretches (1530/1350 cm⁻¹) is a binary "Go/No-Go" indicator that does not require chromatographic separation.

Scenario 2: Purity & Identity Confirmation

Context: Verifying the product before using it in a Grignard reaction.

Alternative	Differentiating Factor via FTIR
Hydrolysis Impurity(3-Aminobenzoic Acid)	Broad O-H Stretch: Acid impurity shows broad "hump" (3300–2500 cm ⁻¹).C=O Shift: Acid dimer C=O appears higher (~1680–1700 cm ⁻¹) than Weinreb amide.
Starting Material(3-Nitro precursor)	NO ₂ Bands: Strong bands at 1530/1350 cm ⁻¹ indicate incomplete reaction.Lack of NH ₂ : Absence of doublet >3300 cm ⁻¹ .

Experimental Protocol: ATR-FTIR Analysis

Objective: Obtain a high-quality spectrum of **3-amino-N-methoxy-N-methylbenzamide** to confirm identity and purity.

Equipment:

- FTIR Spectrometer (e.g., Agilent Cary 630 or Thermo Nicolet iS50).
- ATR Accessory: Diamond or ZnSe crystal (Diamond preferred for durability).
- Solvent: Isopropanol or Ethanol (for cleaning).

Step-by-Step Methodology

- System Preparation:
 - Ensure the ATR crystal is clean. Verify energy throughput is >95% of the installation benchmark.
 - Set parameters: Resolution: 4 cm^{-1} ; Scans: 32 (or 64 for higher S/N); Range: 4000–600 cm^{-1} .
- Background Collection:
 - Collect an air background spectrum. Ensure no $\text{CO}_2/\text{H}_2\text{O}$ interference (purge if necessary).
- Sample Loading:
 - If Liquid/Oil: Place 10–20 μL of the sample directly onto the center of the crystal. Ensure full coverage of the "active spot" (usually 1–2 mm diameter).
 - If Solid: Place ~5 mg of solid on the crystal. Lower the pressure clamp until the "force gauge" indicates optimal contact. Note: Do not overtighten, but ensure intimate contact to eliminate air gaps.
- Acquisition:
 - Start sample scan. Monitor the live display.

- QC Check: Look for the Amide I peak ($\sim 1640\text{ cm}^{-1}$). Absorbance should be between 0.1 and 1.0 A.U. If >1.5 , the detector may be saturating (rare for ATR); if <0.05 , increase sample contact.
- Post-Processing:
 - Apply ATR Correction (if comparing to transmission library spectra).
 - Baseline correct only if significant drift is observed.
 - Peak pick the critical regions (3400, 1640, 1000, 750 cm^{-1}).
- Cleaning:
 - Wipe crystal with a lint-free tissue and Isopropanol. Run a preview scan to ensure no residue remains (carryover check).

Visualizations

Diagram 1: Synthesis Monitoring Logic (Nitro to Amino)

This flowchart illustrates the decision logic when monitoring the reduction of the nitro-precursor to the target amine using FTIR.

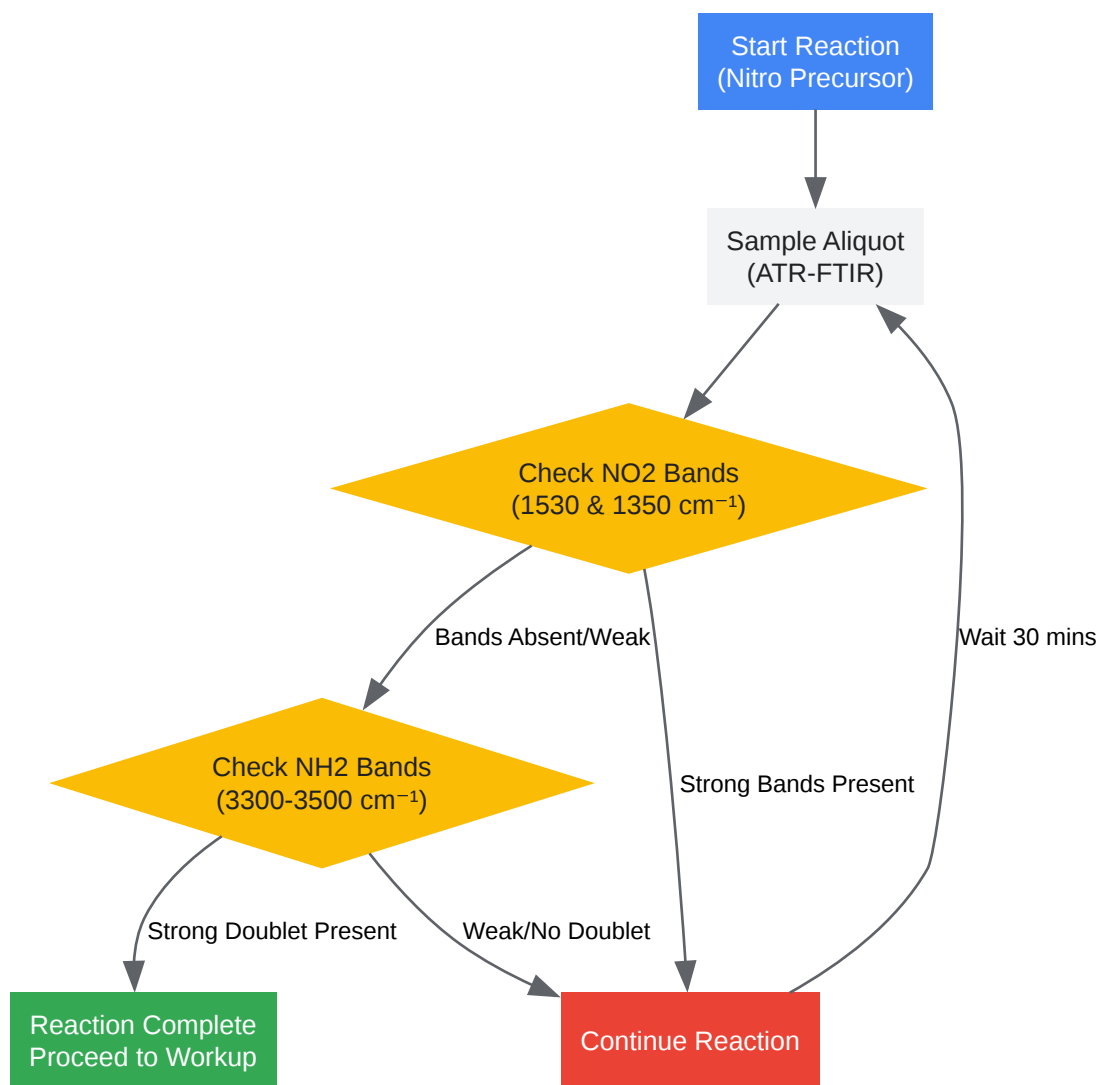

[Click to download full resolution via product page](#)

Caption: Logic flow for monitoring the reduction of the nitro group to the primary amine using characteristic IR bands.

Diagram 2: Spectral Fingerprint Assignment

A visual breakdown of the molecule's structure mapped to its spectral zones.[5]

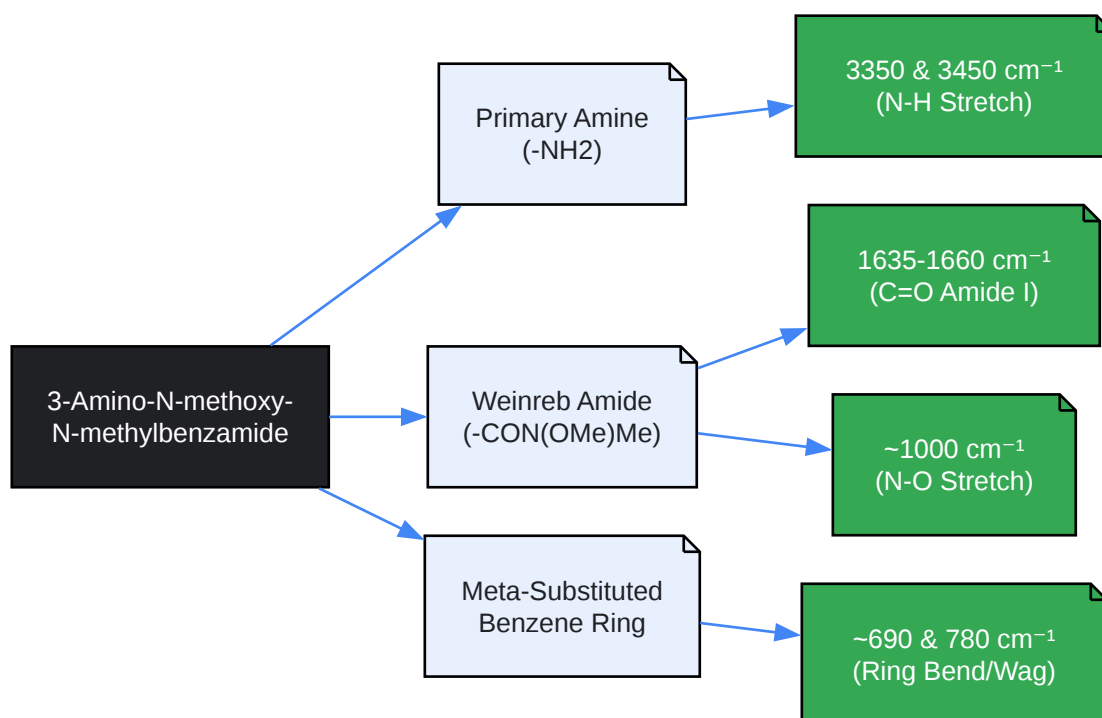

[Click to download full resolution via product page](#)

Caption: Mapping functional groups of **3-amino-N-methoxy-N-methylbenzamide** to their diagnostic FTIR spectral bands.

References

- NIST Chemistry WebBook. Infrared Spectra of 3-Amino-4-methoxybenzamide (Analogous Structure). National Institute of Standards and Technology. Available at: [\[Link\]](#)
- Coates, J. (2000). Interpretation of Infrared Spectra, A Practical Approach. In: Encyclopedia of Analytical Chemistry. R.A. Meyers (Ed.). Chichester: John Wiley & Sons Ltd. (Standard reference for functional group frequencies).
- Spectroscopy Online. The Benzene Fingers, Part I: Distinguishing Mono- and Disubstituted Benzene Rings. Available at: [\[Link\]](#)
- PubChem. 3-amino-4-methoxy-N-methylbenzamide Compound Summary. National Library of Medicine. Available at: [\[Link\]](#)

Need Custom Synthesis?

BenchChem offers custom synthesis for rare earth carbides and specific isotopic labeling.

Email: info@benchchem.com or [Request Quote Online](#).

Sources

- www1.udel.edu [www1.udel.edu]
- [IR Absorption Table](http://webspectra.chem.ucla.edu) [webspectra.chem.ucla.edu]
- spectroscopyonline.com [spectroscopyonline.com]
- [Determination of Secondary Structure in Proteins by FTIR Spectroscopy - JenaLib](http://jenalib.leibniz-fli.de) [jenalib.leibniz-fli.de]
- spectroscopyonline.com [spectroscopyonline.com]
- To cite this document: BenchChem. [Comprehensive Guide: FTIR Spectral Analysis of 3-Amino-N-Methoxy-N-Methylbenzamide]. BenchChem, [2026]. [Online PDF]. Available at: [<https://www.benchchem.com/product/b3214960/docs#comprehensive-guide-ftir-spectral-analysis-of-3-amino-n-methoxy-n-methylbenzamide>]

Disclaimer & Data Validity:

The information provided in this document is for Research Use Only (RUO) and is strictly not intended for diagnostic or therapeutic procedures. While BenchChem strives to provide accurate protocols, we make no warranties, express or implied, regarding the fitness of this product for every specific experimental setup.

Technical Support: The protocols provided are for reference purposes. Unsure if this reagent suits your experiment?

Need Industrial/Bulk Grade? [Request Custom Synthesis Quote](#)

BenchChem

Our mission is to be the trusted global source of essential and advanced chemicals, empowering scientists and researchers to drive progress in science and industry.

Contact

Address: 3281 E Guasti Rd

Ontario, CA 91761, United States

Phone: (601) 213-4426

Email: info@benchchem.com

[Contact our Ph.D. Support Team for a compatibility check](#)