

Technical Support Center: Enhancing the Operational Lifetime of Blue Phosphorescent OLEDs

Author: BenchChem Technical Support Team. **Date:** April 2026

Compound of Interest

Compound Name:	<i>Dibenzofuran, 2-(4'-bromo[1,1'-biphenyl]-4-yl)-</i>
CAS No.:	1084334-69-9
Cat. No.:	B3211190

[Get Quote](#)

A Guide for Researchers and Scientists

The operational lifetime of blue phosphorescent organic light-emitting diodes (PhOLEDs) remains a critical bottleneck for the advancement of next-generation displays and solid-state lighting.^{[1][2][3]} The high photon energy required for blue emission makes the organic materials susceptible to photochemical degradation, leading to a cascade of issues that shorten device lifespan.^{[1][4]} This guide, designed for researchers and drug development professionals venturing into OLED technology, provides a comprehensive troubleshooting framework and addresses frequently asked questions to navigate the complexities of enhancing blue PhOLED stability.

Section 1: Understanding the Core Problem - Why Do Blue PhOLEDs Degrade?

Before troubleshooting, it is crucial to understand the fundamental degradation mechanisms at play. The instability of blue PhOLEDs is not due to a single factor but a combination of intrinsic and extrinsic processes.

Frequently Asked Questions (FAQs): Degradation Mechanisms

Q1: What are the primary reasons for the short operational lifetime of blue PhOLEDs compared to their red and green counterparts?

A1: The primary challenge lies in the high energy of blue light.^{[5][6]} This high energy can lead to several degradation pathways:

- **Intrinsic Material Instability:** The organic molecules used for blue emission inherently have weaker chemical bonds that are more susceptible to breaking under electrical stress and high-energy exciton formation.^{[1][2]}
- **Bimolecular Annihilation Processes:** The long triplet exciton lifetimes in phosphorescent emitters increase the probability of triplet-triplet and triplet-polaron annihilation.^{[1][7][8]} These non-radiative processes release significant energy, which can cause local heating and molecular decomposition.
- **Interfacial Degradation:** Chemical degradation often occurs at the interfaces between different organic layers, particularly between the emissive layer (EML) and the electron transport layer (ETL).^{[4][9][10]} This can involve the loss of oxygen from molecules and the accumulation of degradation products, leading to increased device impedance.^{[9][10]}

Q2: What is the role of the host material in the degradation of the blue phosphorescent emitter?

A2: The host material is critical for the stability of the guest phosphorescent emitter. An ideal host should possess several key characteristics:

- **High Triplet Energy (T1):** The host's triplet energy must be higher than that of the blue phosphor to effectively confine excitons on the guest molecule and prevent energy back-transfer, which can lead to host degradation.^[11]

- **Balanced Charge Transport:** Unbalanced charge injection and transport can lead to the accumulation of charge carriers at interfaces, increasing the likelihood of exciton-polaron annihilation and material degradation.[11] Bipolar host materials, which can transport both holes and electrons, are often employed to create a wider recombination zone and reduce charge accumulation.[12]
- **Morphological and Thermal Stability:** The host material should have a high glass transition temperature (T_g) and decomposition temperature (T_d) to maintain a stable amorphous film during device operation and prevent morphological changes that can lead to shorts or non-emissive pathways.[12][13]

Q3: Can you explain the concept of "exciton-induced degradation" in more detail?

A3: Exciton-induced degradation refers to the chemical breakdown of organic materials caused by the energy released from excitons, particularly long-lived triplet excitons. In blue PhOLEDs, this is a dominant degradation pathway. A critical process is the transition from the desired emissive triplet state (T_1) to a higher-energy, non-emissive triplet metal-centered (3MC) state. [14][15] Population of this 3MC state can lead to ligand dissociation and irreversible decomposition of the phosphorescent emitter.[14]

Visualizing Degradation Pathways

The following diagram illustrates the key degradation pathways in a blue PhOLED.

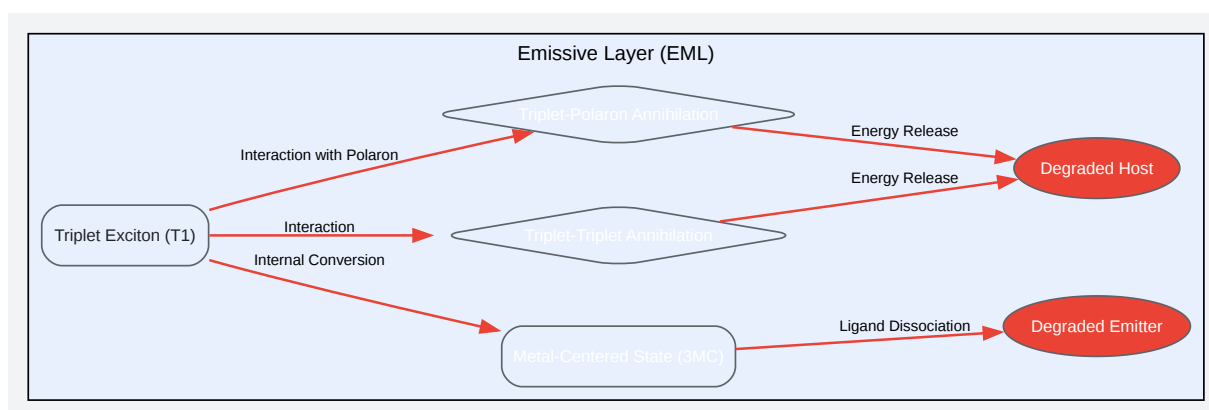

[Click to download full resolution via product page](#)

Caption: Key degradation mechanisms originating from triplet excitons in the emissive layer.

Section 2: Troubleshooting Guide - Common Experimental Issues and Solutions

This section provides a structured approach to troubleshooting common issues encountered during the fabrication and testing of blue PhOLEDs, with a focus on improving operational lifetime.

Issue 1: Rapid Luminance Decay and Short LT50/LT90 Values

Q: My blue PhOLED shows a very fast drop in brightness, with a lifetime significantly shorter than expected. What are the likely causes and how can I address them?

A: Rapid luminance decay is a multifaceted problem. The following troubleshooting steps can help identify and mitigate the root causes.

Step-by-Step Troubleshooting Protocol

- Material Purity and Handling:
 - Problem: Impurities in the organic materials or contamination during fabrication can act as quenching sites for excitons or charge traps, leading to non-radiative recombination and accelerated degradation.[16]
 - Solution:
 - Ensure all organic materials are purified via temperature-gradient sublimation to achieve the highest possible purity.
 - Handle materials and fabricate devices in a controlled inert environment (e.g., a glovebox with low oxygen and moisture levels) to prevent degradation of the materials before and during deposition.[16][17]

- Host and Guest Material Selection and Concentration:
 - Problem: An inappropriate host-guest combination or a non-optimal doping concentration can lead to inefficient energy transfer, exciton quenching, and aggregation of emitter molecules.
 - Solution:
 - Host Selection: Choose a host material with a triplet energy at least 0.2 eV higher than the blue phosphor to ensure efficient exciton confinement.[\[11\]](#) Consider bipolar hosts to balance charge transport.[\[11\]](#)[\[12\]](#) Recent research has also explored pure hydrocarbon hosts to enhance stability.[\[18\]](#)
 - Doping Concentration: Optimize the doping concentration of the phosphorescent emitter. High concentrations can lead to self-quenching and triplet-triplet annihilation. A typical starting point is 5-10 wt%.
- Device Architecture and Interfacial Engineering:
 - Problem: Poor charge balance and exciton confinement within the EML can lead to recombination outside the desired zone and degradation at the interfaces.[\[9\]](#)[\[10\]](#)
 - Solution:
 - Exciton Blocking Layers (EBLs): Introduce an electron-blocking layer (EBL) between the hole-transport layer (HTL) and the EML, and a hole-blocking layer (HBL) between the EML and the ETL. These layers confine excitons within the EML, preventing them from reaching the transport layers where they can cause degradation.
 - Interlayer Materials: Recent studies have shown that novel intermediate layer materials can improve charge injection and transport, reducing operating voltage and enhancing stability.[\[19\]](#)
- Drive Conditions and Measurement Protocol:
 - Problem: Driving the device at a very high current density or temperature during lifetime testing can accelerate degradation mechanisms that may not be dominant under normal

operating conditions.[1]

o Solution:

- Conduct accelerated lifetime testing at various initial luminance levels (e.g., 1000, 5000, 10000 cd/m²) and use a scaling law to extrapolate the lifetime at the target luminance. [1]
- Monitor the device temperature during operation to ensure it does not exceed the glass transition temperature of the organic materials.

Data Summary: Impact of Host Material on Device Lifetime

Host Material Type	Key Characteristics	Typical LT50 at 1000 cd/m ² (hours)
Carbazole-based (e.g., mCP)	Good hole transport, but can have lower T1 for deep blue emitters.	< 100
Bipolar Hosts	Balanced charge transport, wider recombination zone.[11]	100 - 500
Exciplex-forming Hosts	Can offer good charge balance and high efficiency.	500 - 1500+[20]
Pure Hydrocarbon Hosts	Potentially higher intrinsic stability due to the absence of heteroatoms.[18]	Promising results in recent studies.

Issue 2: Color Shift During Operation

Q: The emission color of my blue PhOLED changes over time, often shifting towards green or yellow. What causes this and how can it be prevented?

A: A color shift during operation is a clear indicator of differential aging, where the blue emitter degrades faster than other emissive species that may be present.[7]

Troubleshooting Color Instability

- Degradation of the Blue Emitter:

- Problem: As the blue phosphorescent guest degrades, its contribution to the overall emission spectrum decreases.
- Solution: Implement the strategies outlined in Issue 1 to improve the intrinsic stability of the blue emitter and the overall device architecture.
- Emission from the Host or Interfacial States:
 - Problem: If the host material has a lower triplet energy or if new emissive states are formed at interfaces due to degradation, these can start to contribute to the emission spectrum, causing a color shift.
 - Solution:
 - Select a host with sufficiently high triplet energy.
 - Analyze the electroluminescence spectrum over time to identify the emergence of new emission peaks. This can provide clues about the source of the parasitic emission.
- Formation of Degradation Products:
 - Problem: The chemical degradation of the emitter or host can create new molecules that emit at longer wavelengths (e.g., green or red).[9]
 - Solution: This is a fundamental material stability issue. Molecular design strategies for the emitter, such as introducing bulky side groups to prevent intermolecular interactions and protect the emissive core, can enhance photochemical stability.[20]

Visualizing an Optimized Device Structure

This diagram shows a multi-layer device architecture designed to enhance the stability of a blue PhOLED.

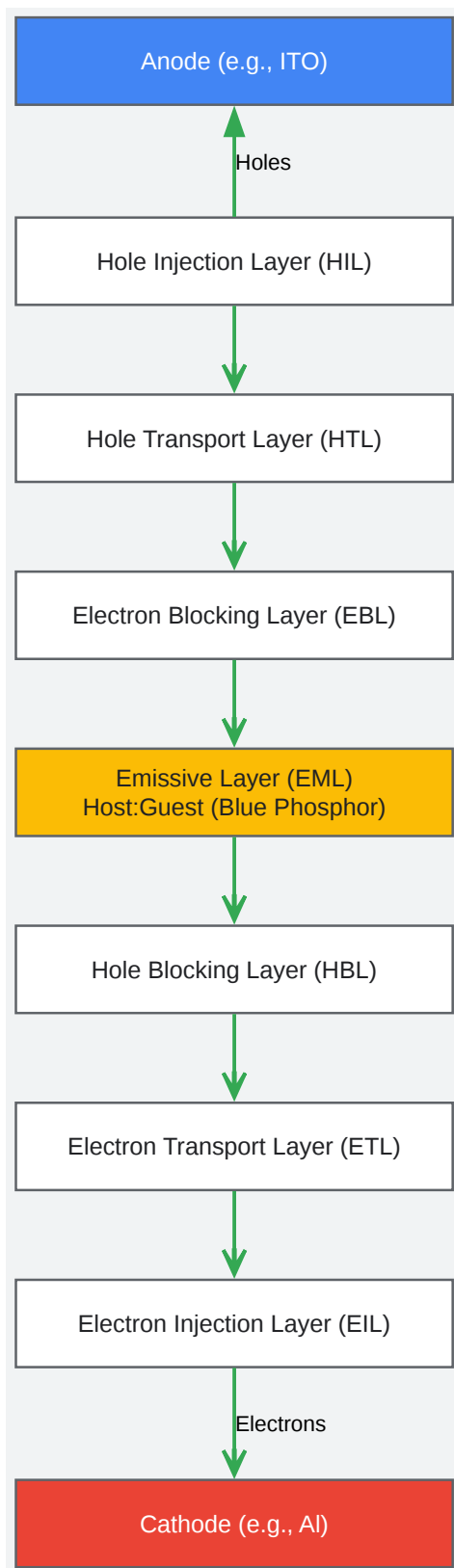

[Click to download full resolution via product page](#)

Caption: A typical multi-layer PhOLED device stack for improved lifetime.

Section 3: Advanced Strategies for Lifetime Enhancement

Beyond basic troubleshooting, several advanced strategies are being explored to push the boundaries of blue PhOLED lifetime.

FAQs: Advanced Concepts

Q1: What is a "tandem OLED" architecture, and how does it improve lifetime?

A1: A tandem OLED architecture consists of two or more individual OLED units stacked on top of each other, connected by a charge generation layer (CGL). This design effectively halves the current density required for a given brightness, which significantly reduces the rate of bimolecular annihilation processes and thus extends the operational lifetime.^{[5][6][21]} Recent breakthroughs have demonstrated that tandem devices can increase the lifetime of blue PhOLEDs by orders of magnitude.^{[3][22]}

Q2: How does molecular design of the phosphorescent emitter impact its stability?

A2: The molecular structure of the phosphorescent emitter is paramount to its stability. Key design strategies include:

- **Increasing the T1-3MC Energy Gap:** By modifying the ligands of the metal complex (e.g., iridium(III) or platinum(II)), it is possible to increase the energy gap between the emissive T1 state and the degradative 3MC state.^{[14][15]} This can be achieved by introducing electron-withdrawing groups or bulky substituents to create steric hindrance.^[15]
- **Enhancing Photochemical Stability:** Introducing bulky groups, such as tert-butyl or triphenylsilyl moieties, can sterically shield the emissive core of the molecule from interactions with neighboring molecules, preventing aggregation and bimolecular quenching.^{[7][20]}

Q3: What is the "Purcell effect" and how is it being used to enhance blue PhOLED stability?

A3: The Purcell effect describes how the emission rate of an emitter can be enhanced by placing it in a resonant optical cavity. In the context of OLEDs, this involves carefully designing the device stack to create a microcavity that resonates at the desired blue wavelength.^{[5][6][23]}

This can be further enhanced by coupling the excitons to surface plasmons at the metal electrodes, a phenomenon known as the polariton-enhanced Purcell (PEP) effect.[22][24] This "exciton fast lane" provides a rapid radiative decay pathway, reducing the time excitons spend in the emissive layer and thus minimizing the chance for non-radiative, degradative processes to occur.[5][21][24]

Section 4: Experimental Protocols

Protocol 1: Fabrication of a High-Stability Blue PhOLED

This protocol outlines the fabrication of a blue PhOLED using thermal evaporation in a high-vacuum system.

Materials:

- Pre-patterned Indium Tin Oxide (ITO) coated glass substrates
- Hole Injection Layer (HIL) material
- Hole Transport Layer (HTL) material
- Electron Blocking Layer (EBL) material
- Host material for the emissive layer
- Blue phosphorescent guest material
- Hole Blocking Layer (HBL) material
- Electron Transport Layer (ETL) material
- Electron Injection Layer (EIL) material (e.g., LiF)
- Cathode material (e.g., Aluminum)

Procedure:

- **Substrate Cleaning:** Thoroughly clean the ITO substrates using a sequence of solvents (e.g., detergent, deionized water, acetone, isopropanol) in an ultrasonic bath. Dry the substrates

with a nitrogen gun and treat with UV-ozone or oxygen plasma to improve the work function of the ITO.

- Organic Layer Deposition: Transfer the cleaned substrates into a high-vacuum thermal evaporation chamber ($<10^{-6}$ Torr).
- Sequentially deposit the organic layers by thermal evaporation. The thickness of each layer should be optimized, but a typical structure is:
 - HIL (10 nm)
 - HTL (40 nm)
 - EBL (10 nm)
 - EML: Host doped with blue phosphor (e.g., 6 wt%) (20 nm)[11]
 - HBL (10 nm)
 - ETL (40 nm)
 - EIL (1 nm)
- Cathode Deposition: Without breaking the vacuum, deposit the metal cathode (e.g., 100 nm of Al) through a shadow mask to define the active area of the device.
- Encapsulation: Transfer the completed device to an inert atmosphere (glovebox) and encapsulate it using a glass lid and UV-curable epoxy to protect the organic layers from moisture and oxygen.

Protocol 2: Accelerated Lifetime Testing

Equipment:

- Source measure unit (SMU)
- Photodiode or spectroradiometer
- Temperature-controlled stage

Procedure:

- Mount the encapsulated device on the temperature-controlled stage.
- Connect the device to the SMU.
- Place the photodiode or the input of the spectroradiometer in front of the device's active area.
- Set the SMU to drive the device at a constant DC current that corresponds to a specific initial luminance (e.g., 1000 cd/m²).
- Continuously monitor and record the luminance and voltage of the device over time.
- The lifetime (e.g., LT50, LT70, LT90) is defined as the time it takes for the luminance to decay to 50%, 70%, or 90% of its initial value.
- Repeat the measurement at different initial luminance levels to determine the acceleration factor.

References

- The Blue Problem: OLED Stability and Degrad
- Chemical degradation mechanisms of highly efficient blue phosphorescent emitters used for organic light emitting diodes | Request PDF - ResearchGate. (URL: [\[Link\]](#))
- The Blue Problem: OLED Stability and Degradation Mechanisms - ACS Publications. (URL: [\[Link\]](#))
- Templated Bipolar Host Materials for Blue Phosphorescent Organic Light-Emitting Devices with Negligible Efficiency Roll-Offs - MDPI. (URL: [\[Link\]](#))
- Novel host material for highly efficient blue phosphorescent OLEDs - ResearchGate. (URL: [\[Link\]](#))
- New design strategy for chemically-stable blue phosphorescent materials: improving the energy gap between the T₁ and T₃ MC states. (URL: [\[Link\]](#))

- A stable blue host material for organic light-emitting diodes - R Discovery. (URL: [\[Link\]](#))
- Degradation Mechanism and Lifetime Improvement Strategy for Blue Phosphorescent Organic Light-Emitting Diodes | Request PDF - ResearchGate. (URL: [\[Link\]](#))
- Direct identification of interfacial degradation in blue OLEDs using nanoscale chemical depth profiling | NPL Publications. (URL: [\[Link\]](#))
- LG Display Achieves Industry First with Blue Phosphorescent OLED. (URL: [\[Link\]](#))
- Universal Bipolar Host Materials for Blue, Green, and Red Phosphorescent OLEDs with Excellent Efficiencies and Small. (URL: [\[Link\]](#))
- Engineering Excited States of Pt-Based Deep-Blue Phosphors to Enhance OLED Stability | ACS Omega. (URL: [\[Link\]](#))
- Blue Polariton-enhanced Purcell phosphorescent OLED emitters boost the lifetime 250 times, may finally unlock blue PHOLEDs | OLED-Info. (URL: [\[Link\]](#))
- OLED Lifetime: introduction and market status. (URL: [\[Link\]](#))
- Extending the lifetime of blue phosphorescent OLEDs (Conference Presentation). (URL: [\[Link\]](#))
- University of Michigan team boosts blue phosphorescent OLED lifetime. A breakthrough toward solving the “blue problem” in displays | UBIResearchNet. (URL: [\[Link\]](#))
- Michigan ups efficiency of OLED screens with its long-life blue PHOLED - Optics.org. (URL: [\[Link\]](#))
- Exceptionally high brightness and long lifetime of efficient blue OLEDs for programmable active-matrix display - PMC. (URL: [\[Link\]](#))
- (PDF) Exceptionally stable blue phosphorescent organic light-emitting diodes. (URL: [\[Link\]](#))
- Are pure hydrocarbons the future of host materials for blue phosphorescent organic light-emitting diodes? - RSC Publishing. (URL: [\[Link\]](#))

- Researchers from Korea develop a new OLED intermediate layer material to improve the performance of blue phosphorescence OLED emitters | OLED-Info. (URL: [\[Link\]](#))
- Breaking the lifetime barrier for deep blue phosphorescent OLEDs - SPIE Digital Library. (URL: [\[Link\]](#))
- The molecular design strategy adopted in the present study for constructing Pt(II) complexes. - ResearchGate. (URL: [\[Link\]](#))
- The Improvement of the Performance of Sky-Blue OLEDs by Decreasing Interface Traps and Balancing Carriers with PSVA Treatment - MDPI. (URL: [\[Link\]](#))
- OLED Screen Lifespan Revealed: How Many Years Will It Last? - Panox Display. (URL: [\[Link\]](#))
- Design of High-Energy-Level Blue Phosphors (A) Molecular structures of... - ResearchGate. (URL: [\[Link\]](#))
- Advances in Blue OLEDs Increase Efficiency and Lifetime - Photonics Spectra. (URL: [\[Link\]](#))
- Breakthrough in Blue PHOLED Extends OLED Screen Lifetime by 250x for Next-Gen Display Technology. (URL: [\[Link\]](#))
- A New Tech Could Fix The Two Major Issues With OLED Screens Of Smartphones And TVs. (URL: [\[Link\]](#))
- Recent breakthroughs in blue OLED material for AMOLED.. (URL: [\[Link\]](#))
- Status and Challenges of Blue OLEDs: A Review - PMC. (URL: [\[Link\]](#))
- LG explains Blue PHOLED screens - Advanced Television. (URL: [\[Link\]](#))
- LG claims to have solved the blue PHOLED puzzle with a new tandem OLED display technology - NotebookCheck.net. (URL: [\[Link\]](#))

Need Custom Synthesis?

BenchChem offers custom synthesis for rare earth carbides and specific isotopic labeling.

Email: info@benchchem.com or [Request Quote Online](#).

Sources

- [1. The Blue Problem: OLED Stability and Degradation Mechanisms - PMC \[pmc.ncbi.nlm.nih.gov\]](#)
- [2. researchgate.net \[researchgate.net\]](#)
- [3. OLED Lifetime: introduction and market status | OLED-Info \[oled-info.com\]](#)
- [4. displaydaily.com \[displaydaily.com\]](#)
- [5. ece.engin.umich.edu \[ece.engin.umich.edu\]](#)
- [6. Michigan ups efficiency of OLED screens with its long-life blue PHOLED \[optics.org\]](#)
- [7. pubs.acs.org \[pubs.acs.org\]](#)
- [8. spiedigitalibrary.org \[spiedigitalibrary.org\]](#)
- [9. researchgate.net \[researchgate.net\]](#)
- [10. Direct identification of interfacial degradation in blue OLEDs using nanoscale chemical depth profiling | NPL Publications \[eprintspublications.npl.co.uk\]](#)
- [11. mdpi.com \[mdpi.com\]](#)
- [12. www2.scut.edu.cn \[www2.scut.edu.cn\]](#)
- [13. discovery.researcher.life \[discovery.researcher.life\]](#)
- [14. khu.elsevierpure.com \[khu.elsevierpure.com\]](#)
- [15. pubs.acs.org \[pubs.acs.org\]](#)
- [16. ossila.com \[ossila.com\]](#)
- [17. Recent breakthroughs in blue OLED material for AMOLED. \[eureka.patsnap.com\]](#)
- [18. Are pure hydrocarbons the future of host materials for blue phosphorescent organic light-emitting diodes? - Materials Chemistry Frontiers \(RSC Publishing\) DOI:10.1039/D2QM00083K \[pubs.rsc.org\]](#)
- [19. Researchers from Korea develop a new OLED intermediate layer material to improve the performance of blue phosphorescence OLED emitters | OLED-Info \[oled-info.com\]](#)

- [20. researchgate.net \[researchgate.net\]](https://www.researchgate.net)
- [21. Blue PHOLED Breakthrough Extends OLED Display Panel Lifetime by 250x | Next-Gen OLED Screen Technology - OLED/LCD Supplier \[panoxdisplay.com\]](#)
- [22. Blue Polariton-enhanced Purcell phosphorescent OLED emitters boost the lifetime 250 times, may finally unlock blue PHOLEDs | OLED-Info \[oled-info.com\]](#)
- [23. ece.engin.umich.edu \[ece.engin.umich.edu\]](https://ece.engin.umich.edu)
- [24. University of Michigan team boosts blue phosphorescent OLED lifetime. A breakthrough toward solving the “blue problem” in displays | UBIResearchNet \[en.ubiresearchnet.com\]](#)
- To cite this document: BenchChem. [Technical Support Center: Enhancing the Operational Lifetime of Blue Phosphorescent OLEDs]. BenchChem, [2026]. [Online PDF]. Available at: [<https://www.benchchem.com/product/b3211190/docs#technical-support-center-enhancing-the-operational-lifetime-of-blue-phosphorescent-oleds>]

Disclaimer & Data Validity:

The information provided in this document is for Research Use Only (RUO) and is strictly not intended for diagnostic or therapeutic procedures. While BenchChem strives to provide accurate protocols, we make no warranties, express or implied, regarding the fitness of this product for every specific experimental setup.

Technical Support: The protocols provided are for reference purposes. Unsure if this reagent suits your experiment?

Need Industrial/Bulk Grade? [Request Custom Synthesis Quote](#)

BenchChem

Our mission is to be the trusted global source of essential and advanced chemicals, empowering scientists and researchers to drive progress in science and industry.

Contact

Address: 3281 E Guasti Rd
Ontario, CA 91761, United States
Phone: (601) 213-4426
Email: info@benchchem.com

Contact our Ph.D. Support Team for a compatibility check