

Technical Support Center: Troubleshooting Regioselectivity in Substituted Pyrazole Synthesis

Author: BenchChem Technical Support Team. **Date:** April 2026

Compound of Interest

Compound Name:	Morpholino(3-nitro-1H-pyrazol-5-yl)methanone
CAS No.:	1045707-16-1
Cat. No.:	B3207642

[Get Quote](#)

Introduction

The pyrazole scaffold is a privileged structure in medicinal chemistry and materials science, found in a wide array of biologically active compounds.[1] The Knorr pyrazole synthesis, a cyclocondensation reaction between a 1,3-dicarbonyl compound and a hydrazine, is a cornerstone method for its preparation.[2] However, when using unsymmetrical starting materials, a critical challenge arises: the potential formation of two distinct regioisomers.[3]

Controlling which isomer is formed is paramount, as different regioisomers can possess vastly different biological, physical, and toxicological properties.[4][5] This guide serves as a technical support center for researchers, scientists, and drug development professionals. It provides in-depth, field-proven insights into diagnosing, troubleshooting, and overcoming regioselectivity issues in substituted pyrazole synthesis through a practical question-and-answer format.

Section 1: Frequently Asked Questions (FAQs) - Understanding the Core Problem

Q1: What exactly is regioselectivity in the context of pyrazole synthesis?

A: Regioselectivity refers to the preference for forming one constitutional isomer over another in a chemical reaction.[6] In pyrazole synthesis, this issue is most prominent when an unsymmetrical 1,3-dicarbonyl compound (where $R^1 \neq R^2$) reacts with a substituted hydrazine (e.g., methylhydrazine, phenylhydrazine). The substituted nitrogen of the hydrazine can attack either of the two non-equivalent carbonyl carbons. This leads to two possible reaction pathways and, consequently, two different regioisomeric pyrazole products.[1] The challenge lies in directing the reaction to produce only the desired isomer.[6]

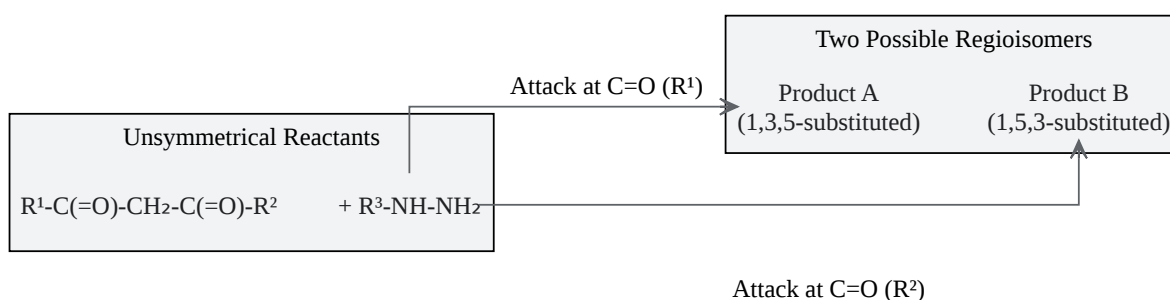

[Click to download full resolution via product page](#)

Caption: Reaction of an unsymmetrical 1,3-dicarbonyl with a substituted hydrazine can lead to two regioisomers.

Section 2: Troubleshooting Guide - Common Issues & Strategic Solutions

This section addresses the most common and frustrating problems encountered during pyrazole synthesis. We break down the "why" behind the problem and provide actionable protocols to solve it.

Issue 1: My reaction is producing a nearly 1:1 mixture of regioisomers. Why is it not selective?

Problem: You're observing poor regioselectivity, where the electronic and steric differences between the two carbonyl groups in your 1,3-dicarbonyl substrate are insufficient to direct the reaction under your current conditions.[4]

The reaction outcome is a competition between two pathways.[3] The initial, and often selectivity-determining, step is the nucleophilic attack of one of the hydrazine's nitrogen atoms on a carbonyl carbon.[7] Several factors govern this choice:

- **Steric Hindrance:** Bulky groups (R^1 , R^2) on the dicarbonyl can physically block the approach of the hydrazine, favoring attack at the less hindered carbonyl.[3]
- **Electronic Effects:** Electron-withdrawing groups (like CF_3) make a carbonyl carbon more electrophilic (electron-poor) and thus a more attractive target for nucleophilic attack.[2]
- **Hydrazine Nucleophilicity:** In a substituted hydrazine ($R^3-NH-NH_2$), the internal nitrogen (-NH-) is generally less nucleophilic than the terminal nitrogen (-NH₂) due to the electronic effect of the R^3 group.

When these competing factors are closely balanced, a mixture of products is the result.

If you are facing a non-selective reaction, modifying the reaction conditions is the most effective troubleshooting strategy.[6]

Strategy A: Solvent Modification (High-Impact Solution)

The choice of solvent can have a dramatic effect on regioselectivity. Standard solvents like ethanol often give mixtures.[8] Fluorinated alcohols, through their unique hydrogen-bonding properties, can significantly stabilize one of the transition states over the other, leading to excellent selectivity.[6]

Protocol: Solvent Screening for Improved Selectivity

- **Setup:** In separate vials, dissolve your 1,3-dicarbonyl compound (1.0 eq) in ethanol, 2,2,2-trifluoroethanol (TFE), and 1,1,1,3,3,3-hexafluoro-2-propanol (HFIP) to a concentration of

~0.2 M.

- Reaction: Add the substituted hydrazine (1.1 eq) to each vial.
- Monitor: Stir at room temperature for 12-24 hours, monitoring by TLC or LC-MS.
- Analysis: Upon completion, analyze the crude product ratio from each reaction by ¹H NMR or HPLC to determine the optimal solvent.

Data Presentation: The Impact of Solvent on Regioisomeric Ratio

The following table demonstrates the powerful effect of solvent choice on the reaction of a trifluoromethyl-substituted 1,3-diketone with methylhydrazine.

Solvent	Dielectric Constant (ε)	Isomer Ratio (A:B)	Selectivity Outcome
Ethanol	24.5	~60 : 40	Low regioselectivity[9]
Toluene	2.4	~65 : 35	Marginal improvement[9]
Acetic Acid	6.2	~75 : 25	Moderate improvement[9]
TFE	8.5	~90 : 10	Significant improvement[9]
HFIP	9.3	>97 : 3	Excellent selectivity[9]

Data adapted from studies on fluorinated alcohol effects.[8][9]
Isomer A results from attack at the carbonyl adjacent to the CF₃ group.

Strategy B: pH Adjustment

The pH of the reaction medium can alter the nucleophilicity of the two nitrogen atoms in a substituted hydrazine.[5]

- **Acidic Conditions:** Under acidic conditions, the more basic nitrogen (typically the substituted one) can be protonated, reducing its nucleophilicity. This favors the initial attack by the terminal -NH₂ group.[9]
- **Neutral/Basic Conditions:** The relative nucleophilicity of the two nitrogens is governed more by the substituent's electronic effects.

Protocol: pH Optimization

- Run the reaction in a standard solvent (e.g., ethanol).
- Set up parallel reactions: one with no additive, one with a catalytic amount of acetic acid (or HCl), and one with a mild base like sodium acetate.
- Monitor the reactions and analyze the final product ratios to determine the optimal pH for your specific substrates.

Issue 2: The major product of my reaction is the undesired regioisomer. How can I reverse the selectivity?

Problem: The inherent steric and electronic properties of your starting materials strongly favor the formation of the wrong product under standard conditions.

This scenario implies that the kinetically favored pathway leads to your undesired product. For example, if your 1,3-dicarbonyl has a small, highly electron-withdrawing group (like formyl or trifluoromethyl) and a large, bulky group, the attack will almost always occur at the more electrophilic carbonyl, regardless of steric hindrance. To reverse this, you must fundamentally alter the factors governing the reaction pathway.

Strategy A: Temperature Control (Kinetic vs. Thermodynamic Control)

Chemical reactions can be under either kinetic or thermodynamic control.[10]

- **Kinetic Control (Low Temp, Short Time):** Favors the product that is formed fastest (i.e., has the lowest activation energy).[11]

- Thermodynamic Control (High Temp, Long Time): Favors the most stable product, allowing the initial products to revert to intermediates and equilibrate.[12]

If the desired isomer is thermodynamically more stable, running the reaction at a higher temperature (e.g., reflux) for a longer duration might shift the product ratio in your favor.[10] Conversely, if the desired product is the kinetic one, lower temperatures are key.[12]

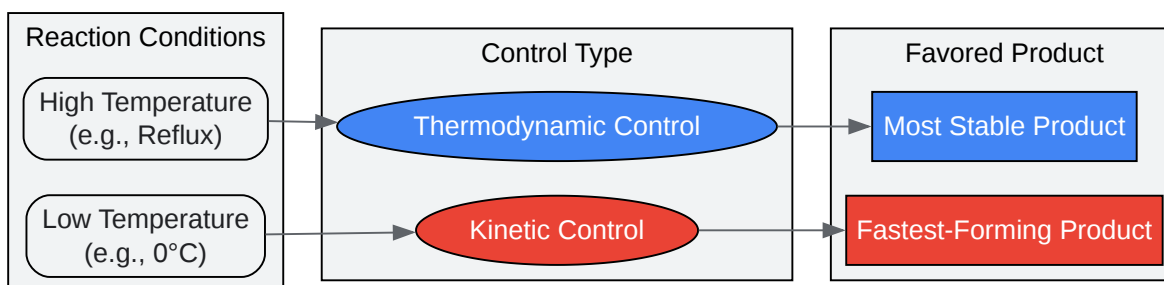

[Click to download full resolution via product page](#)

Caption: Relationship between reaction temperature, control type, and the favored product outcome.

Strategy B: Alternative Synthetic Routes

When reaction conditions fail to provide the desired isomer, a change in strategy is required.

- 1,3-Dipolar Cycloaddition: This powerful method offers high regioselectivity but requires different starting materials.[13] It typically involves the [3+2] cycloaddition of a nitrile imine (generated in situ from a hydrazonoyl halide) with an alkyne or an alkyne surrogate.[14] This approach often provides access to pyrazoles that are difficult to obtain via traditional condensation.[13]
- Synthesis from α,β -Unsaturated Carbonyls (Chalcones): Reacting an α,β -unsaturated ketone or aldehyde with a hydrazine first forms a non-aromatic pyrazoline intermediate.[13] This intermediate must then be oxidized to yield the final pyrazole.[15] The regioselectivity is determined during the initial cyclization step.

Protocol: Two-Step Pyrazole Synthesis from a Chalcone

- **Pyrazoline Formation:** Dissolve the chalcone (1.0 eq) in ethanol. Add the substituted hydrazine (1.1 eq) and reflux for 2-4 hours. Monitor by TLC.[\[13\]](#)
- **Oxidation:** After cooling, the pyrazoline intermediate can be oxidized in situ or after isolation. A common method is to heat the pyrazoline in a solvent like DMSO under an oxygen atmosphere to promote aromatization.[\[15\]](#)

Section 3: Summary of Key Parameters for Controlling Regioselectivity

This table provides a quick reference for the key experimental levers you can pull to influence the regiochemical outcome of your pyrazole synthesis.

Parameter	General Impact on Regioselectivity	Key Insight & Recommendation
Solvent	High Impact. Can dramatically shift or even reverse selectivity.	Action: Screen fluorinated alcohols (TFE, HFIP) first. They often provide superior selectivity compared to ethanol or acetic acid. [6] [8]
pH (Catalyst)	Moderate to High Impact. Alters the nucleophilicity of the hydrazine nitrogens.	Action: Test catalytic amounts of both acid (AcOH, HCl) and base (NaOAc). Acidic conditions often favor attack by the terminal -NH ₂ . [9]
Temperature	Variable Impact. Determines kinetic vs. thermodynamic control.	Action: If you have a mixture, try running the reaction at both 0°C and reflux to see if the product ratio changes significantly. [10]
Substituent Effects	Fundamental Impact. Governs the inherent reactivity of the starting materials.	Action: An electron-withdrawing group (EWG) on the dicarbonyl will activate the adjacent carbonyl. A bulky group will sterically hinder it. [3]
Reactant Stoichiometry	Minor to Moderate Impact. Can sometimes influence the product ratio.	Action: While less common, varying the ratio of dicarbonyl to hydrazine has been shown to affect the regioisomeric ratio in some cases. [16]

References

- Knorr Pyrazole Synthesis: A Detailed Protocol for the Preparation of Substituted Pyrazoles. (2025). Benchchem.
- Discovery of unexpectedly complex reaction pathways for the Knorr pyrazole synthesis via transient flow. (2022). RSC Publishing.
- Troubleshooting the reaction mechanism of pyrazole form

- The reaction between hydrazines and β -dicarbonyl compounds: proposal for a mechanism. Canadian Journal of Chemistry.
- Improved Regioselectivity in Pyrazole Formation through the Use of Fluorinated Alcohols as Solvents: Synthesis and Biological Activity of Fluorinated Tebufenpyrad Analogs. (2008). The Journal of Organic Chemistry.
- Knorr pyrazole synthesis. Name-Reaction.com.
- Technical Support Center: Managing Regioselectivity in Substituted Pyrazole Synthesis. (2025). Benchchem.
- Technical Support Center: Regioselective Synthesis of Substituted Pyrazoles. (2025). Benchchem.
- Synthesis and Pharmacological Activities of Pyrazole Deriv
- common issues and solutions in 5-Hydrazinyl-4-phenyl-1H-pyrazole reactions. (2025). Benchchem.
- troubleshooting low conversion rates in pyrazole synthesis. (2025). Benchchem.
- regioselectivity comparison between different substituted hydrazines in pyrazole synthesis. (2025). Benchchem.
- A Comparative Guide to Alternative Pyrazole Synthesis Methods Beyond Ynones. (2025). Benchchem.
- Regioselectivity issues in the synthesis of substituted pyrazoles
- Thermodynamic reaction control. Wikipedia.
- Novel Regioselective Synthesis of 1,3,4,5-Tetrasubstituted Pyrazoles and Biochemical Valuation on F1FO-ATPase and Mitochondrial Permeability Transition Pore Form
- Kinetic and Thermodynamic Control. Dalal Institute.
- 14.3: Kinetic vs. Thermodynamic Control of Reactions. (2024). Chemistry LibreTexts.

Need Custom Synthesis?

BenchChem offers custom synthesis for rare earth carbides and specific isotopic labeling.

Email: info@benchchem.com or [Request Quote Online](#).

Sources

- [1. pdf.benchchem.com \[pdf.benchchem.com\]](https://pdf.benchchem.com)
- [2. Synthesis and Pharmacological Activities of Pyrazole Derivatives: A Review - PMC \[pmc.ncbi.nlm.nih.gov\]](https://pubmed.ncbi.nlm.nih.gov/123456789/)
- [3. pdf.benchchem.com \[pdf.benchchem.com\]](https://pdf.benchchem.com)

- [4. pdf.benchchem.com \[pdf.benchchem.com\]](#)
- [5. pdf.benchchem.com \[pdf.benchchem.com\]](#)
- [6. pdf.benchchem.com \[pdf.benchchem.com\]](#)
- [7. pdf.benchchem.com \[pdf.benchchem.com\]](#)
- [8. researchgate.net \[researchgate.net\]](#)
- [9. pdf.benchchem.com \[pdf.benchchem.com\]](#)
- [10. Thermodynamic and kinetic reaction control - Wikipedia \[en.wikipedia.org\]](#)
- [11. dalalinstitute.com \[dalalinstitute.com\]](#)
- [12. chem.libretexts.org \[chem.libretexts.org\]](#)
- [13. pdf.benchchem.com \[pdf.benchchem.com\]](#)
- [14. Novel Regioselective Synthesis of 1,3,4,5-Tetrasubstituted Pyrazoles and Biochemical Valuation on F1FO-ATPase and Mitochondrial Permeability Transition Pore Formation - PMC \[pmc.ncbi.nlm.nih.gov\]](#)
- [15. pdf.benchchem.com \[pdf.benchchem.com\]](#)
- [16. Discovery of unexpectedly complex reaction pathways for the Knorr pyrazole synthesis via transient flow - Reaction Chemistry & Engineering \(RSC Publishing\) DOI:10.1039/D2RE00271J \[pubs.rsc.org\]](#)
- To cite this document: BenchChem. [Technical Support Center: Troubleshooting Regioselectivity in Substituted Pyrazole Synthesis]. BenchChem, [2026]. [Online PDF]. Available at: [<https://www.benchchem.com/product/b3207642/docs#technical-support-center-troubleshooting-regioselectivity-in-substituted-pyrazole-synthesis>]

Disclaimer & Data Validity:

The information provided in this document is for Research Use Only (RUO) and is strictly not intended for diagnostic or therapeutic procedures. While BenchChem strives to provide accurate protocols, we make no warranties, express or implied, regarding the fitness of this product for every specific experimental setup.

Technical Support: The protocols provided are for reference purposes. Unsure if this reagent suits your experiment?

Need Industrial/Bulk Grade? [Request Custom Synthesis Quote](#)

BenchChem

Our mission is to be the trusted global source of essential and advanced chemicals, empowering scientists and researchers to drive progress in science and industry.

Contact

Address: 3281 E Guasti Rd

Ontario, CA 91761, United States

Phone: (601) 213-4426

Email: info@benchchem.com

[Contact our Ph.D. Support Team for a compatibility check](#)