

Technical Support Center: Handling 2-Pyridyl Ether Intermediates

Author: BenchChem Technical Support Team. **Date:** April 2026

Compound of Interest

Compound Name: (S)-2-(Pyrrolidin-3-yloxy)-pyridine

CAS No.: 1029805-88-6

Cat. No.: B3204184

[Get Quote](#)

Technical Briefing: The "Grease" Paradox

2-Pyridyl ethers present a unique solubility challenge in organic synthesis. Structurally, they possess a "chameleon" character: the pyridine ring is highly polar and basic, while the ether linkage and attached aryl/alkyl group often add significant lipophilicity and rotational freedom.

The Consequence: These intermediates frequently fail to crystallize, persisting as viscous oils or gums ("oiling out") during aqueous workups. This is often due to:

- **Hydrogen Bonding:** The pyridine nitrogen acts as a hydrogen bond acceptor, holding onto water molecules that disrupt crystal lattice formation.
- **Conformational Flexibility:** The C–O–C ether linkage allows for multiple conformers, entropically disfavoring crystallization.
- **Metal Chelation:** If synthesized via metal catalysis (e.g., Ullmann or Buchwald-Hartwig), trace metal ions can chelate between the ether oxygen and pyridine nitrogen, stabilizing amorphous phases.

This guide addresses these issues with field-proven protocols for solubilization, isolation, and purification.

Part 1: Reaction Optimization (Upstream Solutions)

Q: My 2-pyridyl ether precipitates as a gum during the coupling reaction, stalling conversion. How do I keep it in solution?

A: This "crashing out" usually indicates the reaction solvent is too non-polar to support the growing polar product, or the product is complexing with the metal catalyst.

Troubleshooting Protocol:

- Switch to "Solvent Hybrids": Pure non-polar solvents (Toluene) often fail. Use a 9:1 mixture of Toluene:DMF or Toluene:DMAc. The small amount of polar aprotic solvent disrupts aggregation without killing the catalyst activity.
- Phase Transfer Catalysis (PTC): If using an inorganic base (like

 or

), the surface becomes coated with the gummy product. Add 10 mol% Tetrabutylammonium bromide (TBAB). This acts as a surfactant, keeping the product solubilized in the organic phase and maintaining a clean solid-liquid interface for the base.
- Temperature Control: 2-Pyridyl ethers often have a "solubility floor" around 60°C. Ensure your reaction temperature does not drop below this threshold during addition steps.

Part 2: Workup & Isolation (The "Oiling Out" Crisis)

Q: During aqueous workup, my product formed a distinct third "rag" layer or a sticky oil at the bottom. How do I recover it?

A: This is the most common issue. The product is partially protonated or hydrated. Do not attempt to extract with simple Hexanes/Ethyl Acetate immediately. Use the "Acid-Base Swing" technique to break the hydration shell.

Protocol: The Acid-Base Swing Extraction

This method utilizes the basicity of the pyridine nitrogen () to force the molecule into water, cleaning it of non-basic lipophilic impurities, and then releasing it back to organics.

- **Dissolution:** Dissolve the crude oil in DCM (Dichloromethane). Note: DCM is superior to EtOAc here because it solubilizes the hydrated pyridine species better.
- **Acid Extraction:** Extract the organic layer with 1M HCl (aq). The 2-pyridyl ether will protonate and move to the aqueous layer.
 - **Checkpoint:** Check the organic layer by TLC.^{[1][2][3][4][5]} It should contain your non-basic impurities (unreacted phenols, neutral side products). Discard organic layer if product is absent.
- **Neutralization:** Cool the aqueous layer to 0°C. Slowly basify with 6M NaOH or Sat. until pH > 10. The product will precipitate or oil out as the free base.
- **Re-Extraction:** Extract the cloudy aqueous mixture with TBME (tert-Butyl methyl ether) or DCM.
- **Drying:** Dry over (Sodium Sulfate). Magnesium sulfate can sometimes coordinate to the pyridine; Sodium sulfate is safer.

Workflow Visualization: Isolation Decision Tree

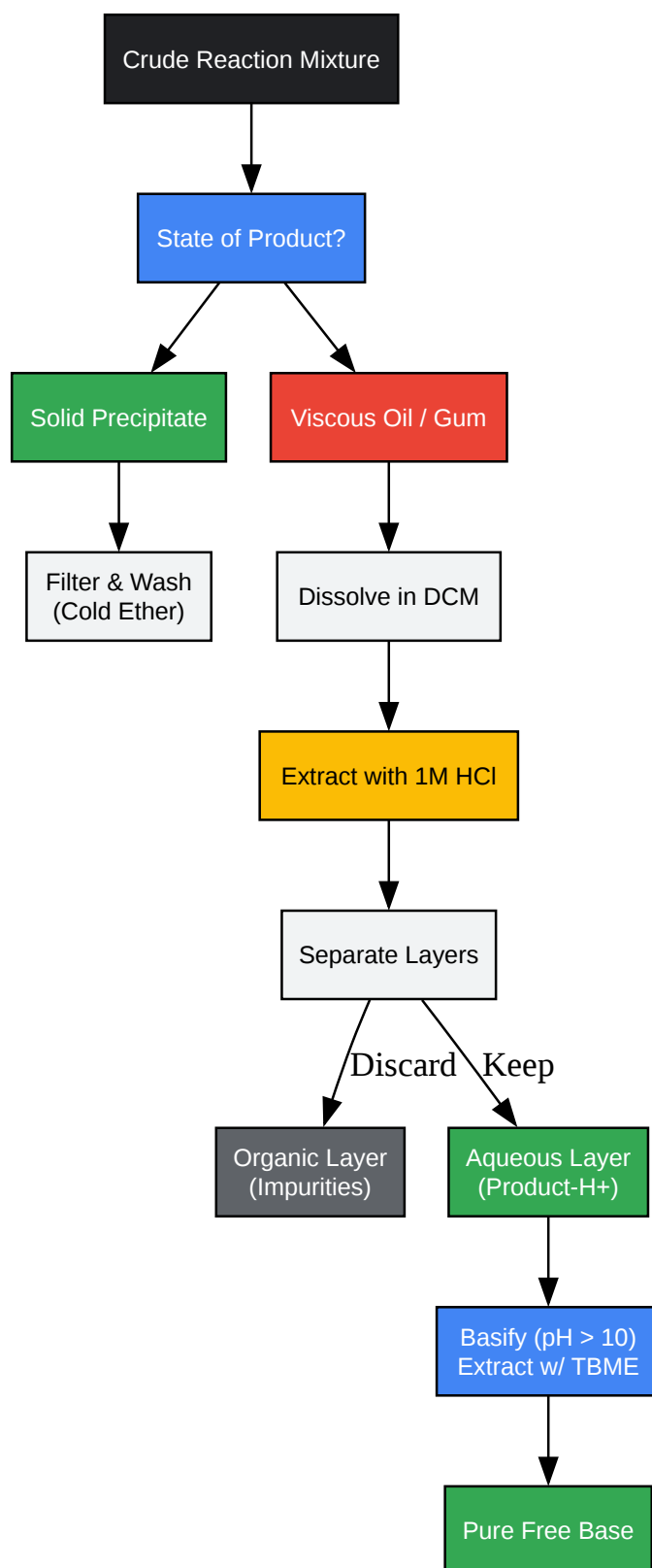

[Click to download full resolution via product page](#)

Figure 1: Decision logic for isolating 2-pyridyl ethers from crude mixtures. The acid-wash step is critical for removing non-basic impurities.

Part 3: Purification & Crystallization

Q: I cannot get the oil to crystallize, even after the acid-base workup. What solvent systems work for 2-pyridyl ethers?

A: 2-pyridyl ethers are notorious for "supercooling"—staying liquid below their freezing point. You must disrupt the intermolecular forces preventing the lattice from locking.

Strategy A: The "Anti-Solvent" Trituration

Standard recrystallization (heat/cool) often fails. Instead, use Cold Trituration.

- Dissolve the oil in a minimum amount of Diethyl Ether or TBME (approx. 1-2 mL per gram).
- Add Hexanes or Pentane dropwise until the solution turns slightly cloudy.
- Scratch the side of the flask with a glass rod (nucleation).
- Place in a -20°C freezer overnight.
- Result: The oil should harden into a white/off-white solid.

Strategy B: Salt Formation (The "Silver Bullet")

If the free base refuses to solidify, convert it to a salt. The Hydrochloride (HCl) or Picrate salts of 2-pyridyl ethers are almost always crystalline solids.

- Protocol: Dissolve oil in dry Ether. Bubble dry HCl gas or add 2M HCl in Ether. Collect the precipitate.
- Benefit: This also purifies the compound.^[4] You can store it as the salt or neutralize it back to the free base immediately before the next step.

Q: What chromatography solvent system should I use? A: Avoid pure Hexane/EtOAc if streaking occurs. Pyridines streak on silica due to interaction with acidic silanols.

- The Fix: Add 1% Triethylamine (TEA) to your eluent.
- Recommended System: 0-50% EtOAc in Hexanes (+1% TEA) OR 0-10% MeOH in DCM (for very polar derivatives).

Part 4: Solubility Data & Solvent Compatibility

The following table summarizes solvent interactions specifically for 2-pyridyl ether intermediates based on polarity and protonation state.

Solvent System	Suitability	Application Context	Technical Note
DCM (Dichloromethane)	Excellent	Extraction / Dissolving Gums	Best for breaking up "oiled out" crude mixtures.
Diethyl Ether	Moderate	Crystallization / Trituration	Good for inducing crystallization when mixed with Hexanes.
Hexanes / Pentane	Poor	Anti-Solvent	Product is usually insoluble; use only to force precipitation.
Methanol / Ethanol	Good	Reaction Solvent / H- Bonding	Can dissolve the product but may inhibit crystallization due to high solubility.
Water (Acidic pH < 3)	High	Purification (Extraction)	Product exists as Pyridinium salt; highly soluble.
Water (Basic pH > 9)	Very Low	Isolation	Product precipitates as free base.

Visualization: Solvent Selection Matrix

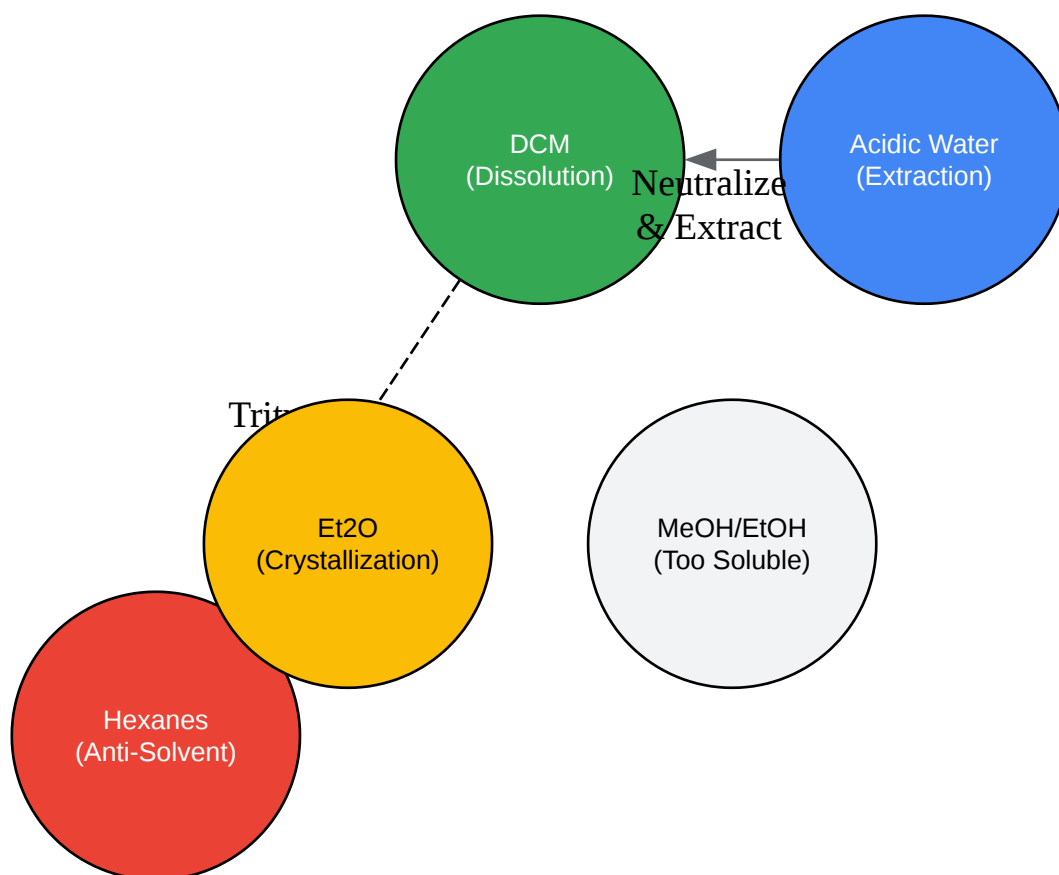

[Click to download full resolution via product page](#)

Figure 2: Solvent Utility Map. Green/Blue nodes represent high utility for solubilization/extraction. Red/Yellow nodes are used for forcing the product out of solution (precipitation).

References

- Cook, X. A., et al. (2020).[6] The 2-Pyridyl Problem: Challenging Nucleophiles in Cross-Coupling Arylations. *Angewandte Chemie International Edition*. Retrieved from [\[Link\]](#)
- Organic Chemistry Portal. (2024). General and Scalable Synthesis of 2-Aryl and 2-Alkyl Pyrimidines via an Electronically Tuned S_NAr Approach. Retrieved from [\[Link\]](#)
- Knapp, D. M., et al. (2010). A General Solution for the 2-Pyridyl Problem. *Journal of the American Chemical Society*. Retrieved from [\[Link\]](#)

- Navuluri, C., et al. (2024).[7] Synthesis of 2-Aryl and 2-Alkyl Pyrimidines. Organic Letters. Retrieved from [[Link](#)]

Need Custom Synthesis?

BenchChem offers custom synthesis for rare earth carbides and specific isotopic labeling.

Email: info@benchchem.com or [Request Quote Online](#).

Sources

- 1. pdf.benchchem.com [pdf.benchchem.com]
- 2. benchchem.com [benchchem.com]
- 3. researchgate.net [researchgate.net]
- 4. pdf.benchchem.com [pdf.benchchem.com]
- 5. US20100222568A1 - Removal of pyridine and pyridine analogs from reaction mass containing sucrose esters - Google Patents [patents.google.com]
- 6. semanticscholar.org [semanticscholar.org]
- 7. General and Scalable Synthesis of 2-Aryl and 2-Alkyl Pyrimidines via an Electronically Tuned S_NAr Approach [organic-chemistry.org]
- To cite this document: BenchChem. [Technical Support Center: Handling 2-Pyridyl Ether Intermediates]. BenchChem, [2026]. [Online PDF]. Available at: [<https://www.benchchem.com/product/b3204184/docs#technical-support-center-handling-2-pyridyl-ether-intermediates>]

Disclaimer & Data Validity:

The information provided in this document is for Research Use Only (RUO) and is strictly not intended for diagnostic or therapeutic procedures. While BenchChem strives to provide accurate protocols, we make no warranties, express or implied, regarding the fitness of this product for every specific experimental setup.

Technical Support: The protocols provided are for reference purposes. Unsure if this reagent suits your experiment?

Need Industrial/Bulk Grade? [Request Custom Synthesis Quote](#)

BenchChem

Our mission is to be the trusted global source of essential and advanced chemicals, empowering scientists and researchers to drive progress in science and industry.

Contact

Address: 3281 E Guasti Rd
Ontario, CA 91761, United States
Phone: (601) 213-4426
Email: info@benchchem.com

[Contact our Ph.D. Support Team for a compatibility check](#)