

Structural Elucidation of 3-(Hydroxymethyl)-4-nitrobenzonitrile: A Comprehensive ¹H NMR Technical Guide

Author: BenchChem Technical Support Team. **Date:** April 2026

Compound of Interest

Compound Name:	3-(Hydroxymethyl)-4-nitrobenzonitrile
CAS No.:	90178-81-7
Cat. No.:	B032704

[Get Quote](#)

Executive Overview

In modern drug development and complex organic synthesis, **3-(Hydroxymethyl)-4-nitrobenzonitrile** (CAS 90178-81-7) serves as a highly versatile, multi-functionalized building block^[1]. Featuring three distinct electronic directors—a cyano group, a nitro group, and a hydroxymethyl moiety—this molecule presents a unique electronic topology. For research scientists, confirming the structural integrity of this compound via Proton Nuclear Magnetic Resonance (¹H NMR) spectroscopy is a critical quality control gateway. This whitepaper provides an authoritative, deeply mechanistic guide to acquiring, interpreting, and validating the ¹H NMR spectrum of this compound.

Mechanistic Insights into the Spin System

The ¹H NMR spectrum of **3-(Hydroxymethyl)-4-nitrobenzonitrile** is governed by the competing electronic effects of its substituents, resulting in a classic AMX aromatic spin system and a distinct aliphatic side-chain signature.

- Nitro Group Anisotropy & Induction: The nitro group (-NO₂) at the C-4 position is a powerful electron-withdrawing moiety via both inductive (-I) and resonance (-R) mechanisms. It creates a strong anisotropic deshielding zone that strips electron density from the adjacent ortho proton (H-5). Consequently, H-5 is pushed significantly downfield, a phenomenon well-documented in related analogs such as 4-nitrobenzonitrile[2].
- Cyano Group Effects: The cyano group (-CN) at C-1 is also electron-withdrawing but possesses a linear geometry. Its anisotropic cone exerts a localized deshielding effect on the ortho protons (H-2 and H-6), though less severe than the nitro group.
- Hydroxymethyl Dynamics: The -CH₂OH group at C-3 introduces critical diagnostic features. In standard non-polar solvents like CDCl₃, the hydroxyl proton undergoes rapid intermolecular chemical exchange, often appearing as a broad, uninformative singlet[3]. However, by strategically altering the solvent environment, we can manipulate this exchange rate to reveal structural connectivity.

Quantitative Data & Spectral Assignments

The following table summarizes the predicted quantitative ¹H NMR data for **3-(Hydroxymethyl)-4-nitrobenzonitrile** when analyzed in an optimized solvent system (anhydrous DMSO-d₆).

Position	Proton Type	Expected Shift (ppm)	Multiplicity	Coupling Constant (J, Hz)	Integration	Assignment Rationale
H-5	Aromatic	8.20 - 8.25	Doublet (d)	~8.5	1H	Strongly deshielded by the ortho-NO ₂ group.
H-2	Aromatic	8.05 - 8.10	Doublet (d)	~1.8	1H	Deshielded by ortho-CN; meta-coupled to H-6.
H-6	Aromatic	7.95 - 8.00	Doublet of doublets (dd)	8.5, 1.8	1H	Ortho-coupled to H-5, meta-coupled to H-2.
-OH	Hydroxyl	5.50 - 5.70	Triplet (t)	~5.5	1H	Exchangeable; locked by solvent to couple with -CH ₂ -.
-CH ₂ -	Methylene	4.80 - 4.90	Doublet (d)	~5.5	2H	Deshielded by adjacent oxygen and aromatic ring.

Self-Validating Experimental Protocol

A robust analytical protocol must not only dictate steps but also prove its own assignments. The primary risk in assigning functionalized aromatics is the misidentification of exchangeable

protons, which can masquerade as impurities. The following methodology is designed as a closed-loop, self-validating system.

Phase 1: High-Resolution Acquisition

- **Gravimetric Preparation:** Weigh exactly 5.0 mg of **3-(Hydroxymethyl)-4-nitrobenzonitrile**. Causality: Maintaining a low, precise concentration prevents viscosity-induced line broadening, ensuring sharp peak resolution for fine meta-couplings.
- **Strategic Solvation:** Dissolve the sample in 0.6 mL of anhydrous DMSO- d_6 (100.0 atom % D) containing 0.03% v/v TMS. Causality: Unlike $CDCl_3$, the strong hydrogen-bonding capability of DMSO- d_6 effectively "locks" the hydroxyl proton, drastically reducing its exchange rate. This allows the observation of vicinal scalar coupling ($^3J \sim 5.5$ Hz) between the -OH and the -CH₂- protons.
- **Instrument Tuning:** Transfer the solution to a 5 mm precision NMR tube. Insert into a 400 MHz (or higher) spectrometer. Perform rigorous tuning, matching, and gradient shimming until the TMS linewidth at half-height is < 1.0 Hz.
- **Pulse Sequence Execution:** Utilize a standard 1D proton sequence (e.g., zg30). Set the relaxation delay (D1) to ≥ 2.0 seconds. Causality: Aromatic protons in highly electron-deficient rings exhibit longer longitudinal (T1) relaxation times. A sufficient D1 prevents signal saturation and ensures highly accurate integration values. Acquire 16 to 32 scans.

Phase 2: The Self-Validating D₂O Shake

To establish absolute trustworthiness, we force the molecule to verify the hydroxymethyl assignment through chemical exchange. 5. **Chemical Exchange Induction:** Remove the NMR tube from the probe. Add 2 drops of Deuterium Oxide (D₂O) directly to the solution and shake vigorously for 30 seconds. 6. **Re-Acquisition:** Re-insert the sample and re-run the identical zg30 pulse sequence. 7. **Validation Analysis:** Compare the spectra. The triplet at ~ 5.60 ppm must completely disappear (as the -OH exchanges to -OD). Concurrently, the doublet at ~ 4.85 ppm (-CH₂-) must collapse into a sharp singlet. This causal relationship unequivocally validates the presence of the intact hydroxymethyl moiety.

Workflow Visualization

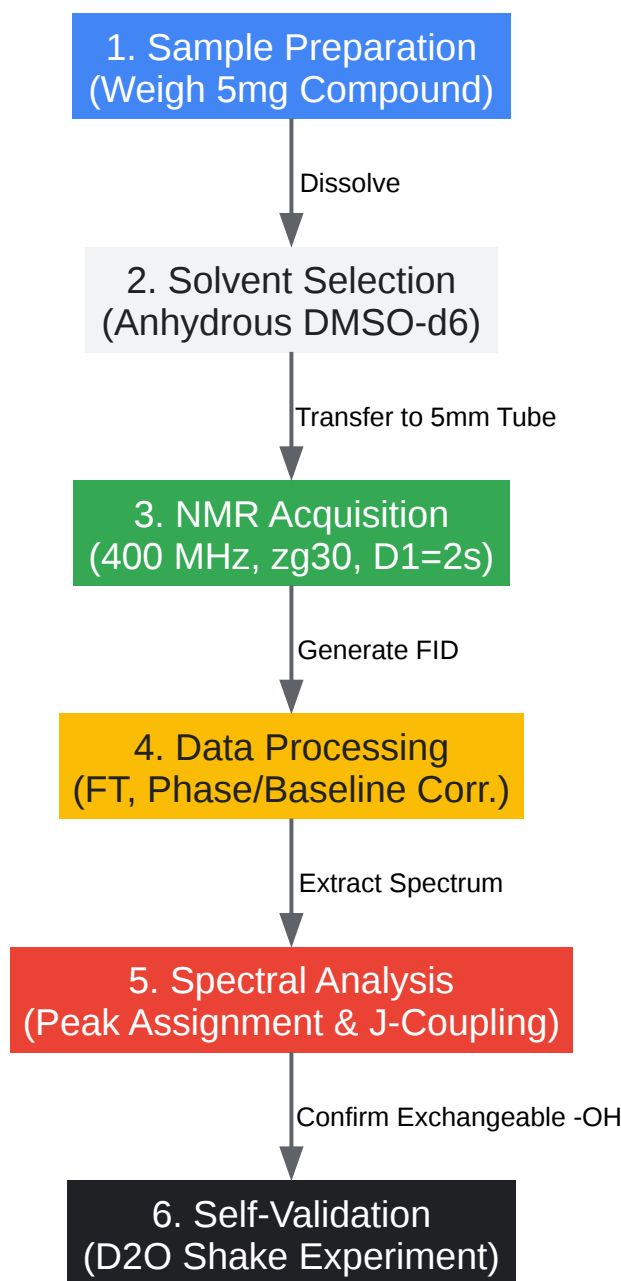

[Click to download full resolution via product page](#)

Flowchart detailing the self-validating ¹H NMR acquisition and analysis workflow.

References

- Title: **3-(Hydroxymethyl)-4-nitrobenzonnitrile** | 90178-81-7 Source: Benchchem URL: [1](#)
- Title: 4-Nitrobenzonnitrile | C₇H₄N₂O₂ | CID 12090 Source: PubChem - NIH URL: [2](#)

- Title: Supporting Information - 3-methyl-4-nitrobenzotrile Source: CDC Stacks URL: [3](#)

Need Custom Synthesis?

BenchChem offers custom synthesis for rare earth carbides and specific isotopic labeling.

Email: info@benchchem.com or [Request Quote Online](#).

Sources

- [1. benchchem.com](https://www.benchchem.com) [benchchem.com]
- [2. 4-Nitrobenzotrile | C7H4N2O2 | CID 12090 - PubChem](https://pubchem.ncbi.nlm.nih.gov/compound/4-Nitrobenzotrile) [pubchem.ncbi.nlm.nih.gov]
- [3. stacks.cdc.gov](https://stacks.cdc.gov) [stacks.cdc.gov]
- To cite this document: BenchChem. [Structural Elucidation of 3-(Hydroxymethyl)-4-nitrobenzotrile: A Comprehensive ¹H NMR Technical Guide]. BenchChem, [2026]. [Online PDF]. Available at: [<https://www.benchchem.com/product/b032704/docs#structural-elucidation-of-3-hydroxymethyl-4-nitrobenzotrile-a-comprehensive-h-nmr-technical-guide>]

Disclaimer & Data Validity:

The information provided in this document is for Research Use Only (RUO) and is strictly not intended for diagnostic or therapeutic procedures. While BenchChem strives to provide accurate protocols, we make no warranties, express or implied, regarding the fitness of this product for every specific experimental setup.

Technical Support: The protocols provided are for reference purposes. Unsure if this reagent suits your experiment?

Need Industrial/Bulk Grade? [Request Custom Synthesis Quote](#)

BenchChem

Our mission is to be the trusted global source of essential and advanced chemicals, empowering scientists and researchers to drive progress in science and industry.

Contact

Address: 3281 E Guasti Rd

Ontario, CA 91761, United States

Phone: (601) 213-4426

Email: info@benchchem.com

[Contact our Ph.D. Support Team for a compatibility check](#)