

High-Throughput Cell-Based Screening for 11 - HSD1 Inhibitors

Author: BenchChem Technical Support Team. **Date:** May 2026

Compound of Interest

Compound Name: 11beta-Hydroxyboldione

CAS No.: 898-84-0

Cat. No.: B032396

[Get Quote](#)

Application Note & Protocol Guide

Introduction: The "Cortisol Switch" in Metabolic Disease

11

-Hydroxysteroid Dehydrogenase Type 1 (11

-HSD1) acts as a molecular switch, amplifying local glucocorticoid action within metabolically active tissues (liver, adipose, brain).[1] Unlike its renal counterpart (Type 2), which inactivates cortisol, 11

-HSD1 functions primarily as a reductase in vivo, converting inactive cortisone into active cortisol.

Elevated 11

-HSD1 activity is implicated in metabolic syndrome, type 2 diabetes, and visceral obesity. Consequently, inhibitors that block this local regeneration of cortisol—without affecting adrenal

cortisol production—are high-value therapeutic targets.

Why Cell-Based Over Biochemical Assays?

While microsomal assays are simpler, they often fail to predict in vivo efficacy. The directionality of 11

-HSD1 is governed by the intracellular NADPH/NADP+ ratio.

- Biochemical Assays: Often lack the NADPH regenerating system (Hexose-6-Phosphate Dehydrogenase), leading to unstable reaction kinetics or bidirectional flux.
- Cell-Based Assays: Maintain the physiological redox potential, ensuring the enzyme functions strictly as a reductase, providing a more predictive model for drug efficacy.

Biological Mechanism & Assay Principle[2][3][4][5][6][7][8]

The core objective of the screening assay is to quantify the reduction of Cortisone (substrate) to Cortisol (product) and identify compounds that inhibit this conversion.

Pathway Diagram

The following diagram illustrates the intracellular enzymatic pathway and the intervention point for inhibitors.

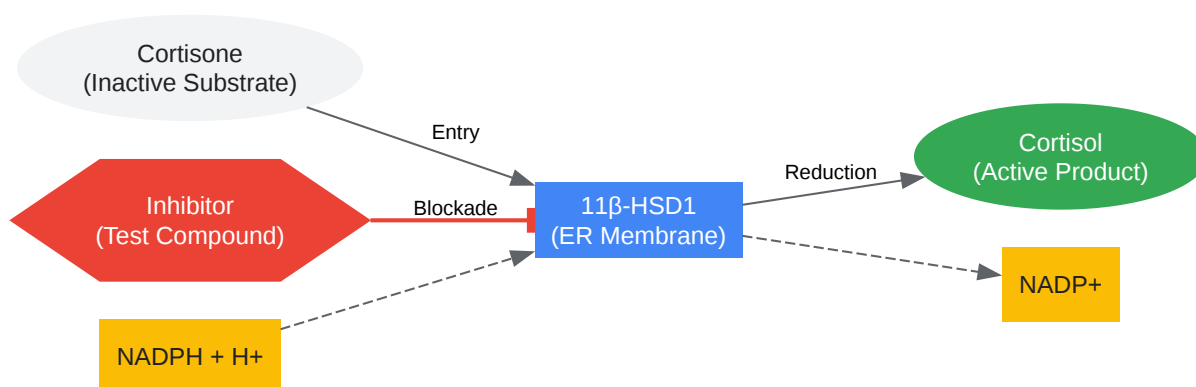

[Click to download full resolution via product page](#)

Figure 1: The 11

-HSD1 Reductase Pathway.[2][3][4] The enzyme utilizes NADPH to reduce the ketone group at position 11 of cortisone, yielding cortisol.[5]

Primary Protocol: Homogeneous Time-Resolved Fluorescence (HTRF)[5][6][7][12]

The HTRF assay is the industry gold standard for 11

-HSD1 screening due to its "mix-and-read" format (no wash steps) and high stability.

Assay Principle: Competitive Immunoassay

This is a competitive assay.[6][5][7][8]

- Reaction: Cells convert Cortisone

Cortisol.[1][9]

- Detection:
 - Reagent A: Anti-Cortisol antibody labeled with Cryptate (Donor).[6][5][8]
 - Reagent B: d2-labeled Cortisol (Acceptor).[6][5][8]
- Signal Logic:
 - Low Enzyme Activity (Inhibition): Low natural cortisol. d2-Cortisol binds freely to the Cryptate-Antibody. High FRET Signal.
 - High Enzyme Activity (No Inhibition): High natural cortisol produced. It competes with d2-Cortisol, displacing it. Low FRET Signal.

Materials Required[2][3][5][6][7][9][11][12][13][15]

- Cell Line: HEK293 stably transfected with human HSD11B1 (or transiently transfected using BacMam).
- Substrate: Cortisone (Sigma-Aldrich, Cat# C2755).

- Detection Kit: HTRF Cortisol Kit (e.g., Revvity/Cisbio).
- Plate: 384-well Low Volume White Plate (Greiner or Corning).
- Reader: HTRF-compatible reader (e.g., PHERAstar, EnVision).

Step-by-Step Workflow

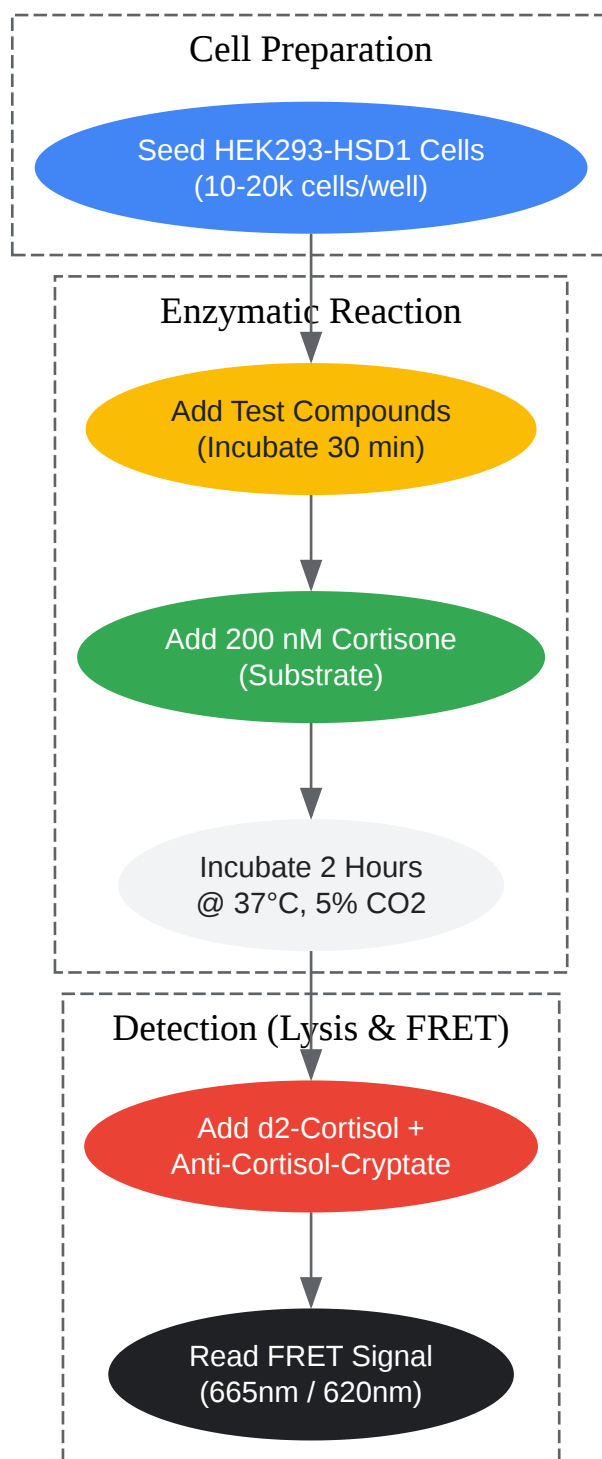

[Click to download full resolution via product page](#)

Figure 2: HTRF Screening Workflow.[8] The entire process occurs in a single well without washing.

Detailed Protocol Steps

- Cell Preparation:
 - Harvest HEK293-HSD1 cells using Accutase (avoid Trypsin if possible to preserve surface integrity, though less critical for intracellular enzymes).
 - Resuspend in assay buffer (DMEM phenol-free + 1% Charcoal-stripped FBS).
 - Dispense 10 μ L of cell suspension (approx. 20,000 cells) into each well of a 384-LV plate.
- Compound Addition:
 - Add 2 μ L of test compound (diluted in assay buffer containing <1% DMSO final).
 - Control Wells: Add vehicle (DMSO) only.
 - Incubate for 30 minutes at 37°C to allow compound entry.
- Substrate Initiation:
 - Prepare 1.2 μ M Cortisone working solution in assay buffer.
 - Add 2 μ L of Cortisone working solution to all wells (Final concentration ~200 nM).
 - Negative Control: Add buffer without Cortisone to define the "No Activity" baseline.
 - Incubate for 2 hours at 37°C.
- Detection:
 - Add 5 μ L of d2-Cortisol.
 - Add 5 μ L of Anti-Cortisol-Cryptate.
 - Note: These reagents usually contain lysis buffer components that stop the enzymatic reaction.
 - Incubate for 2 hours at Room Temperature (dark).

- Measurement:
 - Read on an HTRF-compatible plate reader.
 - Excitation: 337 nm (Laser/Flash lamp).
 - Emission 1: 620 nm (Donor reference).
 - Emission 2: 665 nm (Acceptor FRET).[\[6\]](#)

Data Analysis & Validation

Calculation

HTRF results are ratiometric, which corrects for well-to-well quenching or pipetting errors.

- Calculate Ratio:

[\[5\]](#)

- Calculate Delta F (%):

(Note: In competitive assays, it is often easier to normalize simply: High Ratio = Low Cortisol = High Inhibition).

- Inhibition %:

Requires a standard curve to interpolate actual Cortisol concentrations, or use the inverse relationship of the FRET signal.

Reference Compounds & Performance

Compound	Mechanism	Expected IC50 (Cell-Based)	Notes
Carbenoxolone	Non-selective	0.3 - 0.5 μ M	Standard positive control. Also inhibits 11 -HSD2.
Glycyrrhetic Acid	Non-selective	\sim 0.3 μ M	Active metabolite of licorice.
BVT-2733	Selective	\sim 100 nM	Rodent-selective inhibitor (use for mouse cell lines).
AZD4017	Selective	< 10 nM	Highly potent human 11 -HSD1 inhibitor.

Acceptance Criteria:

- Z' Factor: > 0.5 (Excellent assays typically achieve > 0.7).
- Signal-to-Background (S/B): > 5-fold difference between "No Substrate" and "Substrate + Vehicle".

Alternative Methodology: Scintillation Proximity Assay (SPA)[16]

While HTRF is preferred, SPA remains a robust alternative for labs requiring direct radiometric validation.

- Principle: Uses beads coated with Protein A and anti-cortisol antibody. Tritiated Cortisol (H-Cortisol) is used as a tracer.
- Workflow:

- Incubate cells with compounds and
H-Cortisone.
- Lyse cells.
- Add SPA beads coupled with anti-cortisol antibody.
- H-Cortisol (product) binds the bead
Light emission.
- H-Cortisone (substrate) does not bind antibody
No signal.
- Pros: Very sensitive; direct measurement of conversion.
- Cons: Radioactive waste; requires specialized readers (MicroBeta).

Troubleshooting Guide

Issue	Probable Cause	Solution
Low Signal Window	Low Enzyme Expression	Check transfection efficiency or passage number. For transient assays, optimize BacMam MOI.
High Variability (CV%)	Pipetting / Edge Effects	Use automated dispensing for 384-well plates. Centrifuge plates (1000 rpm, 1 min) before reading.
False Positives	Fluorescence Interference	Compounds fluorescing at 620/665nm. HTRF ratiometric reading usually corrects this, but check raw data.
No Inhibition with Controls	Substrate Saturation	Ensure Cortisone concentration is near (~200-300 nM). Too much substrate overwhelms competitive inhibitors.

References

- Assay Development & HTRF Methodology
 - Wang, D. Y., et al. (2008). "Development of a high-throughput cell-based assay for 11beta-hydroxysteroid dehydrogenase type 1 using BacMam technology." *Molecular Biotechnology*.
- Biological Context & Inhibitors
 - Gathercole, L. L., et al. (2013).[\[10\]](#) "11beta-Hydroxysteroid dehydrogenase 1: translational and therapeutic aspects." *Endocrine Reviews*.
- Protocol Grounding (Cisbio/Revvity)

- Revvity Applic
-HSD1 Screening." (Search: HTRF Cortisol)
- Scintillation Proximity Assay (SPA)
 - Solly, K., et al. (2005). "High-throughput screening of 11beta-hydroxysteroid dehydrogenase type 1 in scintillation proximity assay format." Assay Drug Dev Technol.

Need Custom Synthesis?

BenchChem offers custom synthesis for rare earth carbides and specific isotopic labeling.

Email: info@benchchem.com or [Request Quote Online](#).

Sources

- [1. High-throughput screening of 11beta-hydroxysteroid dehydrogenase type 1 in scintillation proximity assay format - PubMed \[pubmed.ncbi.nlm.nih.gov\]](#)
- [2. researchgate.net \[researchgate.net\]](#)
- [3. The 11 beta-OHSD inhibitor, carbenoxolone, enhances Na retention by aldosterone and 11-deoxycorticosterone - PubMed \[pubmed.ncbi.nlm.nih.gov\]](#)
- [4. In vitro methods to assess 11β-hydroxysteroid dehydrogenase type 1 activity - PubMed \[pubmed.ncbi.nlm.nih.gov\]](#)
- [5. bmglabtech.com \[bmglabtech.com\]](#)
- [6. resources.revvity.com \[resources.revvity.com\]](#)
- [7. resources.rndsystems.com \[resources.rndsystems.com\]](#)
- [8. revvity.com \[revvity.com\]](#)
- [9. Discovery of novel inhibitor of 11 beta-hydroxysteroid dehydrogenase type 1 using in silico structure-based screening approach for the treatment of type 2 diabetes - PMC \[pmc.ncbi.nlm.nih.gov\]](#)
- [10. Inhibition of 11β-Hydroxysteroid dehydrogenase-1 with AZD4017 in patients with nonalcoholic steatohepatitis or nonalcoholic fatty liver disease: A randomized, double-blind, placebo-controlled, phase II study - PMC \[pmc.ncbi.nlm.nih.gov\]](#)

- To cite this document: BenchChem. [High-Throughput Cell-Based Screening for 11 -HSD1 Inhibitors]. BenchChem, [2026]. [Online PDF]. Available at: [<https://www.benchchem.com/product/b032396/docs#high-throughput-cell-based-screening-for-11-hsd1-inhibitors>]

Disclaimer & Data Validity:

The information provided in this document is for Research Use Only (RUO) and is strictly not intended for diagnostic or therapeutic procedures. While BenchChem strives to provide accurate protocols, we make no warranties, express or implied, regarding the fitness of this product for every specific experimental setup.

Technical Support: The protocols provided are for reference purposes. Unsure if this reagent suits your experiment?

Need Industrial/Bulk Grade? [Request Custom Synthesis Quote](#)

BenchChem

Our mission is to be the trusted global source of essential and advanced chemicals, empowering scientists and researchers to drive progress in science and industry.

Contact

Address: 3281 E Guasti Rd
Ontario, CA 91761, United States
Phone: (601) 213-4426
Email: info@benchchem.com

[Contact our Ph.D. Support Team for a compatibility check](#)