

# An In-depth Technical Guide to the Endogenous Synthesis of Lipoxin A4

**Author:** BenchChem Technical Support Team. **Date:** February 2026

## Compound of Interest

Compound Name: *Lipoxin A4*

CAS No.: 89663-86-5

Cat. No.: B032801

[Get Quote](#)

Intended Audience: Researchers, scientists, and drug development professionals.

## Abstract

**Lipoxin A4** (LXA4) is a specialized pro-resolving mediator (SPM) that plays a pivotal role in the resolution of inflammation. Unlike classical anti-inflammatory molecules that broadly suppress the immune response, LXA4 actively orchestrates the return to tissue homeostasis.

Understanding the nuances of its endogenous synthesis is paramount for harnessing its therapeutic potential. This technical guide provides a comprehensive overview of the core biosynthetic pathways of LXA4, detailing the enzymatic machinery, cellular cooperativity, and regulatory mechanisms that govern its production. Furthermore, this guide offers practical insights into experimental methodologies for studying LXA4 synthesis, from in vitro cell culture models to analytical quantification, equipping researchers with the foundational knowledge to explore this critical pro-resolving pathway.

## Introduction: The Resolution of Inflammation and the Role of Lipoxin A4

Inflammation is a fundamental protective response to infection or tissue injury. However, its dysregulation can lead to chronic inflammatory diseases. The resolution of inflammation is now understood to be an active, highly regulated process, not merely a passive decay of pro-

inflammatory signals. Specialized pro-resolving mediators (SPMs), including the lipoxins, are key players in this process.[1]

**Lipoxin A4** (LXA4), an eicosanoid derived from arachidonic acid, was one of the first SPMs to be identified.[2][3] Its biological actions are multifaceted and include inhibiting neutrophil infiltration, stimulating the non-phlogistic phagocytosis of apoptotic cells by macrophages, and promoting tissue repair.[1][4] A thorough understanding of how LXA4 is synthesized endogenously is crucial for the development of novel therapeutics that can promote the resolution of inflammation.

## The Precursor: Arachidonic Acid

The biosynthesis of all lipoxins begins with the 20-carbon polyunsaturated fatty acid, arachidonic acid (AA). AA is typically esterified in the sn-2 position of membrane phospholipids and is released by the action of phospholipase A2 (PLA2) in response to various cellular stimuli. The availability of free AA is the rate-limiting step for the synthesis of eicosanoids, including lipoxins.

## Core Biosynthetic Pathways of Lipoxin A4

The synthesis of LXA4 is a prime example of intricate intercellular communication, often requiring the coordinated action of different cell types in a process known as transcellular biosynthesis.[1] There are three primary pathways for the endogenous production of LXA4.

### The 15-LOX/5-LOX Pathway

This pathway involves the sequential action of 15-lipoxygenase (15-LOX) and 5-lipoxygenase (5-LOX).[1][2]

- **Step 1: 15-LOX-mediated oxygenation of Arachidonic Acid.** In cells such as epithelial cells, monocytes, and eosinophils, 15-LOX introduces molecular oxygen at carbon-15 of arachidonic acid, forming 15(S)-hydroperoxyeicosatetraenoic acid (15(S)-HpETE).[5][6] This intermediate is then rapidly reduced to 15(S)-hydroxyeicosatetraenoic acid (15(S)-HETE).
- **Step 2: Transcellular transfer and 5-LOX-mediated conversion.** 15(S)-HETE is released from the donor cell and taken up by neutrophils, which are rich in 5-LOX.[5] Inside the neutrophil,

5-LOX converts 15(S)-HETE into an unstable epoxide intermediate, 5(6)-epoxy-15(S)-hydroxy-eicosatetraenoic acid.

- Step 3: Enzymatic hydrolysis to **Lipoxin A4**. This epoxide intermediate is then enzymatically hydrolyzed to form **Lipoxin A4** (5S,6R,15S-trihydroxy-7,9,13-trans-11-cis-eicosatetraenoic acid).[2]

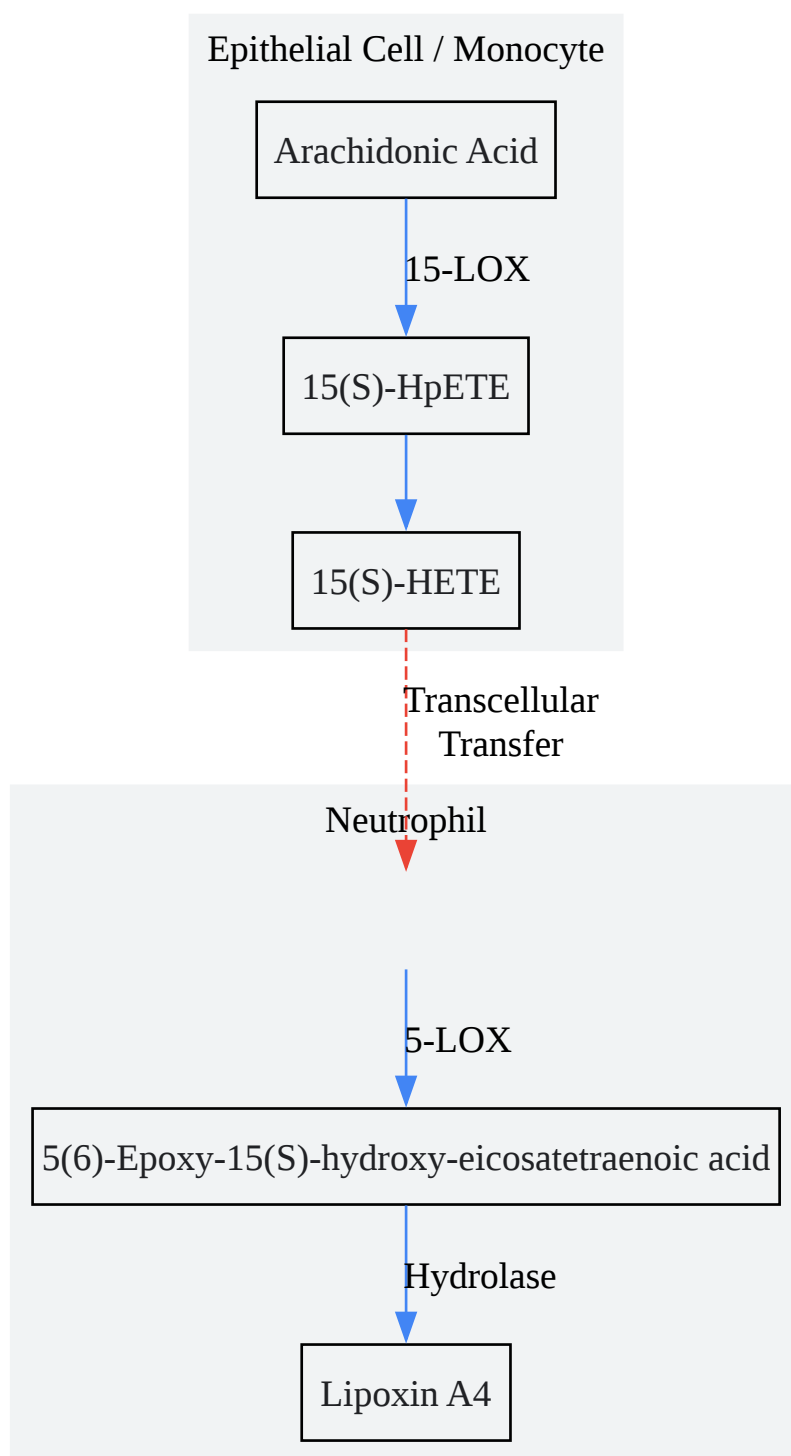

[Click to download full resolution via product page](#)

Caption: The 15-LOX/5-LOX pathway for **Lipoxin A4** synthesis.

## The 5-LOX/12-LOX Pathway

This pathway is a classic example of transcellular biosynthesis involving neutrophils and platelets.[6][7]

- Step 1: 5-LOX-mediated formation of Leukotriene A4 in Neutrophils. Upon activation, neutrophils metabolize arachidonic acid via the 5-LOX pathway to produce the unstable epoxide, Leukotriene A4 (LTA4).
- Step 2: Transcellular transfer of LTA4 to Platelets. LTA4 is released from the neutrophil and rapidly taken up by adjacent platelets.[7]
- Step 3: 12-LOX-mediated conversion to **Lipoxin A4** in Platelets. Platelets, which are rich in 12-lipoxygenase (12-LOX), convert LTA4 into LXA4 and its isomer, Lipoxin B4 (LXB4).[7]

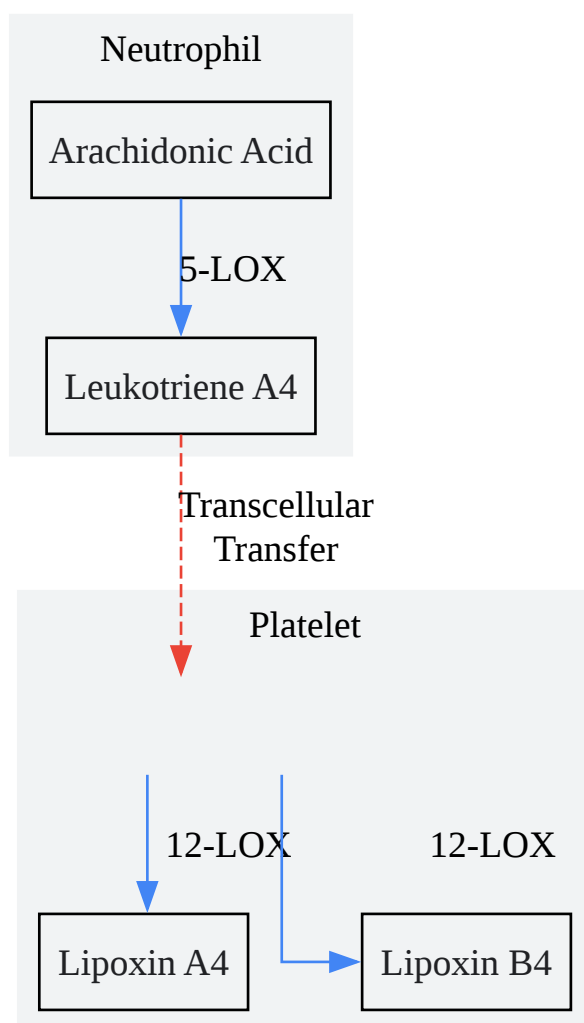

[Click to download full resolution via product page](#)

Caption: The 5-LOX/12-LOX pathway for **Lipoxin A4** synthesis.

## Aspirin-Triggered Lipoxin (ATL) Synthesis

A unique pathway for the generation of a stereoisomer of LXA4, 15-epi-LXA4 (also known as Aspirin-Triggered Lipoxin or ATL), is initiated by the action of aspirin on cyclooxygenase-2 (COX-2).[5][8]

- Step 1: Aspirin-mediated acetylation of COX-2. Aspirin irreversibly acetylates a serine residue in the active site of COX-2, which alters its catalytic activity. Instead of producing prostaglandins, the acetylated COX-2 converts arachidonic acid into 15(R)-hydroxyeicosatetraenoic acid (15(R)-HETE).[9] This occurs primarily in endothelial and epithelial cells where COX-2 is expressed.[10]
- Step 2: Transcellular transfer and 5-LOX-mediated conversion. 15(R)-HETE is then released and taken up by neutrophils.
- Step 3: 5-LOX-mediated formation of 15-epi-LXA4. In neutrophils, 5-LOX metabolizes 15(R)-HETE to generate 15-epi-LXA4. 15-epi-LXA4 is more resistant to metabolic inactivation than native LXA4, prolonging its pro-resolving actions.

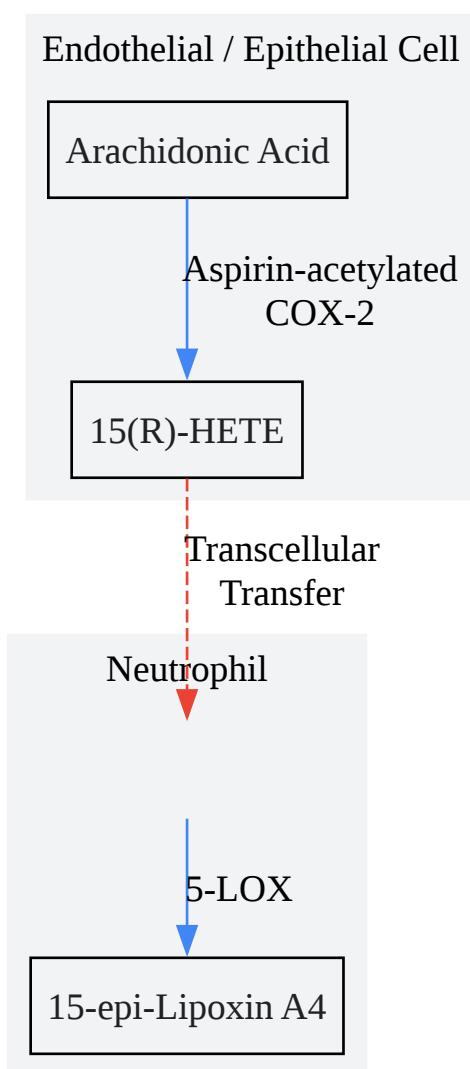

[Click to download full resolution via product page](#)

Caption: Aspirin-Triggered Lipoxin (15-epi-LXA4) synthesis pathway.

## Experimental Methodologies for Studying Lipoxin A4 Synthesis

Investigating the endogenous synthesis of LXA4 requires a combination of in vitro cell culture systems and sophisticated analytical techniques.

### In Vitro Models for Lipoxin A4 Synthesis

- Neutrophil-Platelet Co-culture for 5-LOX/12-LOX Pathway:

- Isolate human neutrophils and platelets from peripheral blood of healthy donors using standard density gradient centrifugation techniques.
- Co-incubate neutrophils and platelets at a physiological ratio (e.g., 1:50 to 1:100) in a suitable buffer (e.g., Hanks' Balanced Salt Solution with calcium and magnesium).
- Simultaneously stimulate both cell types with agonists such as f-Met-Leu-Phe (fMLP) for neutrophils and thrombin for platelets to initiate the synthesis.[7]
- Incubate for a defined period (e.g., 15-30 minutes) at 37°C.
- Terminate the reaction by adding a cold organic solvent (e.g., methanol) and proceed with lipid extraction.
- Epithelial Cell Culture for 15-LOX Precursor Generation:
  - Culture human bronchial epithelial cells (NHBE) or other relevant epithelial cell lines to confluence.
  - Stimulate the cells with pro-inflammatory cytokines such as IL-1 $\beta$  to upregulate COX-2 expression for studying the aspirin-triggered pathway.[8]
  - For the 15-LOX pathway, cells can be treated with stimuli known to induce 15-LOX expression or activity.
  - To study the aspirin-triggered pathway, pre-treat the cells with aspirin before adding arachidonic acid.
  - Collect the cell culture supernatant containing the released 15-HETE or 15(R)-HETE for subsequent addition to neutrophil cultures or for direct analysis.

## Extraction of Lipoxins from Biological Samples

Solid-phase extraction (SPE) is a widely used and effective method for purifying and concentrating lipoxins from complex biological matrices like cell culture supernatants, plasma, or tissue homogenates.[11][12][13]

Step-by-Step Solid-Phase Extraction Protocol:

- **Sample Acidification:** Acidify the aqueous sample (e.g., cell culture supernatant) to a pH of approximately 3.5 with a dilute acid (e.g., 0.1 M HCl). This protonates the carboxylic acid group of the lipoxins, making them less polar and facilitating their retention on a reversed-phase sorbent.
- **SPE Cartridge Conditioning:** Condition a C18 SPE cartridge by sequentially washing with methanol (e.g., 5-10 mL) followed by water (e.g., 5-10 mL).[13]
- **Sample Loading:** Load the acidified sample onto the conditioned SPE cartridge at a slow, controlled flow rate.
- **Washing:** Wash the cartridge with a non-polar solvent like hexane to remove non-polar lipids, followed by an aqueous wash (e.g., water/methanol 9:1, v/v) to remove polar interferences. [13]
- **Elution:** Elute the lipoxins from the cartridge with a suitable organic solvent, such as methyl formate or ethyl acetate (e.g., 5-10 mL).[13]
- **Drying and Reconstitution:** Evaporate the eluate to dryness under a gentle stream of nitrogen. Reconstitute the dried residue in a small volume of the mobile phase used for LC-MS/MS analysis (e.g., methanol/water, 50:50, v/v).[13]

## Quantification of Lipoxin A4 by LC-MS/MS

Liquid chromatography-tandem mass spectrometry (LC-MS/MS) is the gold standard for the sensitive and specific quantification of lipoxins.

Key Parameters for LC-MS/MS Analysis:

Parameter	Typical Conditions	Rationale
Chromatography		
Column	C18 reversed-phase column (e.g., 2.1 x 150 mm, 1.8 μm particle size)	Provides good separation of lipoxins from other eicosanoids based on their hydrophobicity. [14][15]
Mobile Phase	A: Water with 0.02% formic acid; B: Acetonitrile/Methanol (e.g., 80:20, v/v) with 0.02% formic acid	Volatile mobile phases are essential for MS compatibility. The gradient elution from a lower to a higher percentage of organic solvent separates the analytes. [16][17]
Flow Rate	0.2-0.4 mL/min	Optimized for the column dimensions to achieve good chromatographic resolution.
Mass Spectrometry		
Ionization Mode	Negative Electrospray Ionization (ESI-)	The carboxylic acid group of lipoxins is readily deprotonated, forming negative ions.
Detection Mode	Multiple Reaction Monitoring (MRM)	Provides high selectivity and sensitivity by monitoring specific precursor-to-product ion transitions for LXA4 and its internal standard.
MRM Transitions	LXA4: e.g., m/z 351.2 -> 115.1; Deuterated LXA4 (internal standard): e.g., m/z 356.2 -> 115.1	These transitions are characteristic of the fragmentation of LXA4 and are used for its specific detection and quantification.

Validation of the LC-MS/MS Method: A robust LC-MS/MS method should be validated for linearity, accuracy, precision, limit of detection (LOD), and limit of quantification (LOQ) according to established guidelines.<sup>[18][19][20]</sup> The use of a stable isotope-labeled internal standard (e.g., d5-LXA4) is crucial for accurate quantification, as it corrects for variations in sample preparation and instrument response.

## Lipoxygenase Activity Assays

Assessing the activity of the key enzymes involved in LXA4 synthesis can provide valuable insights. Spectrophotometric assays are commonly used for this purpose.

General Principle of Lipoxygenase Activity Assay: Lipoxygenases catalyze the formation of conjugated dienes from polyunsaturated fatty acids like arachidonic acid. These conjugated dienes have a characteristic UV absorbance at 234 nm.<sup>[21][22][23]</sup>

Spectrophotometric Lipoxygenase Activity Assay Protocol:

- Prepare a reaction mixture containing a suitable buffer (e.g., phosphate buffer, pH 7.4) and the substrate (e.g., sodium linoleate or arachidonic acid).
- Initiate the reaction by adding the enzyme source (e.g., cell lysate or purified enzyme).
- Monitor the increase in absorbance at 234 nm over time using a spectrophotometer.
- The rate of increase in absorbance is directly proportional to the lipoxygenase activity.

## Regulation of Lipoxin A4 Synthesis

The endogenous synthesis of LXA4 is tightly regulated at multiple levels:

- **Substrate Availability:** The release of arachidonic acid from membrane phospholipids by PLA2 is a key regulatory step.
- **Enzyme Expression and Activity:** The expression and activity of the lipoxygenases (5-LOX, 12-LOX, 15-LOX) and COX-2 are regulated by various stimuli, including cytokines and growth factors. For example, pro-inflammatory cytokines can upregulate COX-2 expression, priming the system for aspirin-triggered lipoxin synthesis.<sup>[8]</sup>

- Cellular Interactions: The proximity and activation state of the different cell types involved in transcellular biosynthesis are critical for efficient LXA4 production.

## Conclusion

The endogenous synthesis of **Lipoxin A4** is a sophisticated and highly regulated process that underscores the complexity of the resolution of inflammation. Its reliance on transcellular biosynthesis highlights the importance of intercellular communication in maintaining tissue homeostasis. For researchers in drug discovery and development, a deep understanding of these synthetic pathways and the methodologies to study them is essential. By elucidating the mechanisms that govern LXA4 production, we can identify novel therapeutic targets and develop innovative strategies to promote the resolution of inflammation in a wide range of diseases.

## References

- Ariel, A., & Serhan, C. N. (2007). Lipoxins and resolvins in the resolution of inflammation. *Journal of Lipid Research*, 48(9), 1967–1976.
- Bandeira-Melo, C., & Weller, P. F. (2005). Lipoxins and other lipid mediators in the resolution of inflammation. *Current Opinion in Immunology*, 17(2), 177–182.
- Chiang, N., Arita, M., & Serhan, C. N. (2005). Anti-inflammatory circuitry: lipoxin, aspirin-triggered lipoxins and their receptor ALX.
- Dalli, J., & Serhan, C. N. (2012). Specific lipid mediator signatures of human phagocytes: resolvins, protectins, and maresins. *Proceedings of the National Academy of Sciences*, 109(37), E2482–E2491.
- Ferreirós, N., Homann, J., & Geisslinger, G. (2014).
- Gladine, C., Newman, J. W., & Durand, T. (2019). Technical recommendations for liquid chromatography mass spectrometry analysis of oxylipins. *Free Radical Biology and Medicine*, 144, 72–84.
- Gobbetti, T., Le Faouder, P., & Gronert, K. (2023). Aspirin modulates production of pro-inflammatory and pro-resolving mediators in endothelial cells. *PLoS One*, 18(4), e0284483.
- Gonzalez-Covarrubias, V. (2023). Validation of a UPLC-MS/MS Method for Multi-Matrix Biomonitoring of Alternaria Toxins in Humans. *Toxins*, 15(7), 429.
- Serhan, C. N., & Sheppard, K. A. (1990). Lipoxin formation during human neutrophil-platelet interactions. Evidence for the transformation of leukotriene A4 by platelet 12-lipoxygenase in vitro.
- Kieran, N. E., Maderna, P., & Godson, C. (2009). Lipoxins: revolutionary road. *British journal of pharmacology*, 158(4), 947–959.

- Li, H., & Zeldin, D. C. (2023). Promising Anti-Inflammatory Tools: Biomedical Efficacy of Lipoxins and Their Synthetic Pathways. *International Journal of Molecular Sciences*, 24(17), 13324.
- Lima-Garcia, J. F., Dutra, R. C., & Calixto, J. B. (2011). The role of lipoxygenase pathway in the development of inflammatory pain. *Current pharmaceutical design*, 17(13), 1296–1307.
- Nascimento-Silva, V., Arruda, M. A., Barja-Fidalgo, C., Villela, C. G., & Fierro, I. M. (2005). Novel lipid mediator aspirin-triggered **lipoxin A4** induces heme oxygenase-1 in endothelial cells. *American journal of physiology. Cell physiology*, 289(3), C557–C563.
- Ostermann, A. I., Willenberg, I., & Schebb, N. H. (2015). A rapid and robust LC-MS/MS method for the simultaneous determination of 65 eicosanoids and other oxylipins. *Journal of lipid research*, 56(3), 724–735.
- Pastore, D., Fratianni, A., & Mastrodonato, F. (2000). A practical spectrophotometric approach for the determination of lipoxygenase activity of durum wheat. *Journal of Cereal Science*, 31(1), 45-52.
- Pavan, B., Biondi, C., & Dalpiaz, A. (2016). The controversial role of **lipoxin A4** in the resolution of inflammation.
- Ramis, I., Mancera, R. L., & Llinàs, A. (2023). An LC–MS/MS quantification method development and validation for the dabrafenib in biological matrices. *Journal of Applied Pharmaceutical Science*, 13(01), 173-181.
- Romano, M., Cianci, E., & Recchiuti, A. (2010). Lipoxins and aspirin-triggered lipoxins in resolution of inflammation. *European journal of pharmacology*, 643(1), 1-11.
- Schopfer, F. J., & Freeman, B. A. (2014).
- Serhan, C. N. (2007). Resolution phase of inflammation: novel endogenous anti-inflammatory and pro-resolving lipid mediators and pathways. *Annual review of immunology*, 25, 101-137.
- Serhan, C. N., & Petasis, N. A. (2011). Resolvins and protectins in inflammation resolution. *Chemical reviews*, 111(10), 5922-5943.
- Serhan, C. N., Hamberg, M., & Samuelsson, B. (1984). Lipoxins: novel series of biologically active compounds formed from arachidonic acid in human leukocytes. *Proceedings of the National Academy of Sciences*, 81(17), 5335-5339.
- Serhan, C. N. (1994). Lipoxin biosynthesis and its impact in inflammatory and vascular events. *Biochimica et Biophysica Acta (BBA)-Lipids and Lipid Metabolism*, 1212(1), 1-25.
- Spite, M., & Serhan, C. N. (2010). Novel lipid mediators promote resolution of acute inflammation: impact of aspirin and statins.
- Sun, A. R., Wu, X., & Liu, B. (2023). Synthesis of lipoxin. Three major lipoxygenases (LO)
- Vlasova, I. I. (2018).
- Wang, Y., & DuBois, R. N. (2010). Eicosanoids and cancer.

- Wu, S. H., & Lu, C. (2023). Nanostructured **Lipoxin A4**: Understanding Its Biological Behavior and Impact on Alzheimer's Disease (Proof of Concept). *International Journal of Molecular Sciences*, 24(11), 9358.
- Ye, Y., & Lin, Y. (2022). Therapeutic Potential of **Lipoxin A4** in Chronic Inflammation: Focus on Cardiometabolic Disease. *Journal of medicinal chemistry*, 65(13), 8753-8774.
- Zhang, X., & Hu, J. (2023). Modern Methods of Sample Preparation for the Analysis of Oxylipins in Biological Samples. *Molecules*, 28(13), 5133.
- Shimadzu. (n.d.). Mobile phases compatible for LC/MS. Retrieved from [[Link](#)]
- Sketchviz. (n.d.). Graphviz Examples and Tutorial. Retrieved from [[Link](#)]
- GitHub. (n.d.). Complex GraphViz DOT Sample. Retrieved from [[Link](#)]
- The Serhan Laboratory. (n.d.). Specialized Pro-Resolving Mediators and Eicosanoids- A Preferred Solid-Phase Extraction Protocol from Tissues and Biological Flu. Retrieved from [[Link](#)]
- MDPI. (2022). Comprehensive Analysis of Different Subtypes of Oxylipins to Determine a LC–MS/MS Approach in Clinical Research. Retrieved from [[Link](#)]
- ResearchGate. (2006). Application of Graph-based Data Mining to Metabolic Pathways. Retrieved from [[Link](#)]
- Medium. (2022). Graph Visualisation Basics with Python, Part III: Directed Graphs with graphviz. Retrieved from [[Link](#)]
- Wikipedia. (n.d.). Aspirin. Retrieved from [[Link](#)]
- Protocols.io. (2020). Lipoxygenase activity determination V.1. Retrieved from [[Link](#)]
- Phenomenex. (n.d.). SAMPLE PREPARATION. Retrieved from [[Link](#)]

### *Need Custom Synthesis?*

*BenchChem offers custom synthesis for rare earth carbides and specific isotopic labeling.*

*Email: [info@benchchem.com](mailto:info@benchchem.com) or [Request Quote Online](#).*

## Sources

- [1. Lipoxins: resolutionary road - PMC \[pmc.ncbi.nlm.nih.gov\]](#)
- [2. Promising Anti-Inflammatory Tools: Biomedical Efficacy of Lipoxins and Their Synthetic Pathways - PMC \[pmc.ncbi.nlm.nih.gov\]](#)
- [3. scispace.com \[scispace.com\]](#)
- [4. Therapeutic Potential of Lipoxin A4 in Chronic Inflammation: Focus on Cardiometabolic Disease - PMC \[pmc.ncbi.nlm.nih.gov\]](#)
- [5. researchgate.net \[researchgate.net\]](#)
- [6. researchgate.net \[researchgate.net\]](#)
- [7. Lipoxin formation during human neutrophil-platelet interactions. Evidence for the transformation of leukotriene A4 by platelet 12-lipoxygenase in vitro - PMC \[pmc.ncbi.nlm.nih.gov\]](#)
- [8. Aspirin modulates production of pro-inflammatory and pro-resolving mediators in endothelial cells | PLOS One \[journals.plos.org\]](#)
- [9. Aspirin - Wikipedia \[en.wikipedia.org\]](#)
- [10. Aspirin modulates production of pro-inflammatory and pro-resolving mediators in endothelial cells - PMC \[pmc.ncbi.nlm.nih.gov\]](#)
- [11. Detailed Protocol for Solid-Phase Extraction for Lipidomic Analysis - PubMed \[pubmed.ncbi.nlm.nih.gov\]](#)
- [12. Modern Methods of Sample Preparation for the Analysis of Oxylipins in Biological Samples - PMC \[pmc.ncbi.nlm.nih.gov\]](#)
- [13. serhanlab.bwh.harvard.edu \[serhanlab.bwh.harvard.edu\]](#)
- [14. Lipoxin A4: problems with its determination using reversed phase chromatography-tandem mass spectrometry and confirmation with chiral chromatography - PubMed \[pubmed.ncbi.nlm.nih.gov\]](#)
- [15. zenodo.org \[zenodo.org\]](#)
- [16. Mobile phases compatible for LC/MS : SHIMADZU \(Shimadzu Corporation\) \[shimadzu.com\]](#)
- [17. mdpi.com \[mdpi.com\]](#)
- [18. mdpi.com \[mdpi.com\]](#)

- [19. Development, validation and application of an LC-MS/MS method quantifying free forms of the micronutrients queuine and queuosine in human plasma using a surrogate matrix approach - PubMed \[pubmed.ncbi.nlm.nih.gov\]](#)
- [20. japsonline.com \[japsonline.com\]](#)
- [21. Lipoxygenase activity determination \[protocols.io\]](#)
- [22. researchgate.net \[researchgate.net\]](#)
- [23. protocols.io \[protocols.io\]](#)
- To cite this document: BenchChem. [An In-depth Technical Guide to the Endogenous Synthesis of Lipoxin A4]. BenchChem, [2026]. [Online PDF]. Available at: [\[https://www.benchchem.com/product/b032801#endogenous-synthesis-of-lipoxin-a4\]](https://www.benchchem.com/product/b032801#endogenous-synthesis-of-lipoxin-a4)

---

### Disclaimer & Data Validity:

The information provided in this document is for Research Use Only (RUO) and is strictly not intended for diagnostic or therapeutic procedures. While BenchChem strives to provide accurate protocols, we make no warranties, express or implied, regarding the fitness of this product for every specific experimental setup.

**Technical Support:** The protocols provided are for reference purposes. Unsure if this reagent suits your experiment? [[Contact our Ph.D. Support Team for a compatibility check](#)]

**Need Industrial/Bulk Grade?** [Request Custom Synthesis Quote](#)

## BenchChem

Our mission is to be the trusted global source of essential and advanced chemicals, empowering scientists and researchers to drive progress in science and industry.

### Contact

Address: 3281 E Guasti Rd

Ontario, CA 91761, United States

Phone: (601) 213-4426

Email: [info@benchchem.com](mailto:info@benchchem.com)