

application of 4-Benzylcyclohexanamine in medicinal chemistry

Author: BenchChem Technical Support Team. **Date:** May 2026

Compound of Interest

Compound Name: 4-Benzylcyclohexanamine

CAS No.: 100617-11-6

Cat. No.: B3197514

[Get Quote](#)

This guide details the application of **4-Benzylcyclohexanamine** (specifically the trans-isomer) in medicinal chemistry.[1][2] It distinguishes this scaffold as a critical "conformational lock" used to improve the metabolic stability and receptor selectivity of flexible drug candidates.[2]

Application Note: 4-Benzylcyclohexanamine in Drug Discovery

Part 1: Core Directive & Strategic Analysis

The "Rigid Spacer" Principle In medicinal chemistry, **4-benzylcyclohexanamine** is not merely a reagent; it is a bioisostere for flexible alkyl chains (e.g., propyl or butyl linkers) and diphenylmethane derivatives. By replacing a flexible chain with a cyclohexane ring, chemists "freeze" the bioactive conformation, often resulting in:

- Entropy Reduction: Lowering the entropic penalty of binding to a receptor pocket.[2]
- Metabolic Protection: The cyclohexane ring is less prone to rapid oxidative metabolism compared to linear alkyl chains.[2]

- Stereochemical Control: The ability to select between cis (kinked) and trans (linear) geometries allows for precise probing of receptor depth.[2]

Primary Therapeutic Areas:

- Sigma-1 () Receptor Ligands: The trans-4-benzylcyclohexyl moiety mimics the hydrophobic pharmacophore required for high-affinity binding, investigated for neuroprotective and analgesic effects.[2]
- NAAA Inhibitors: Carbamate derivatives of **4-benzylcyclohexanamine** are potent inhibitors of N-acyl ethanolamine acid amidase (NAAA), a target for inflammation and pain.[2][3]
- GPCR Antagonists: Used as a spacer in Neurokinin-1 (NK1) and Dopamine D3 receptor antagonists (structurally related to the drug Cariprazine, which uses a similar trans-cyclohexyl spacer).[2]

Part 2: Scientific Integrity & Logic (The "Why" and "How")

Structural Logic: The Trans vs. Cis Dichotomy

The biological activity of **4-benzylcyclohexanamine** derivatives is almost exclusively driven by the (1r,4r)-trans isomer.[2]

- Trans-Isomer (Diequatorial): In the lowest energy chair conformation, both the bulky benzyl group and the amine (or amide) group occupy equatorial positions.[2] This creates an extended, linear molecule (~6-7 Å length across the ring) that fits deep into hydrophobic channels of receptors (e.g., the GPCR transmembrane bundle).
- Cis-Isomer (Axial-Equatorial): Forces one substituent into an axial position, creating a "bent" structure.[2] This is typically inactive for targets requiring a linear spacer and is considered an impurity.[2]

Validated Protocol: Synthesis and Stereocontrol

Direct hydrogenation of 4-benzylaniline typically yields a difficult-to-separate mixture of cis and trans isomers.[2] The preferred route utilizes 4-benzylcyclohexanone via reductive amination, followed by thermodynamic equilibration or selective crystallization.[2]

Mechanism of Action (NAAA Inhibition Example): In NAAA inhibitors, the 4-benzylcyclohexyl group acts as a lipophilic "anchor" that mimics the endogenous fatty acid chain of PEA (palmitoylethanolamide), positioning the carbamate warhead in the catalytic site to block hydrolysis.[2]

Part 3: Protocols & Experimental Guides

Protocol A: Stereoselective Synthesis of trans-4-Benzylcyclohexanamine

Objective: To synthesize the thermodynamically stable trans-isomer with >95% diastereomeric excess (de).

Reagents:

- 4-Benzylcyclohexanone (1.0 equiv)[2]
- Hydroxylamine hydrochloride (1.2 equiv)[2]
- Sodium acetate (1.5 equiv)[2]
- Sodium metal / Ethanol (for reduction) OR Raney Nickel/H₂.[2]

Step-by-Step Workflow:

- Oxime Formation:
 - Dissolve 4-benzylcyclohexanone in Ethanol/Water (3:1).[2]
 - Add

and NaOAc.[2] Reflux for 2 hours.
 - Checkpoint: Monitor TLC (Hexane/EtOAc 4:1).[2] The ketone spot should disappear.[2]

- Cool and filter the white solid (Oxime).[2] Yield is typically >90%.[2]
- Reduction to Amine (Sodium/Ethanol Method):
 - Note: This method favors the thermodynamically stable trans-amine.[2]
 - Dissolve the oxime in absolute ethanol.[2] Heat to reflux.[2][4]
 - Add small pieces of Sodium metal (Caution: H₂ evolution) over 1 hour until 10 equiv are added.
 - Reflux for an additional 2 hours to ensure isomerization to the trans form.[2]
- Purification (The "Isomer Trap"):
 - Quench reaction with water; extract with DCM.[2]
 - Crucial Step: Convert the crude amine to the Hydrochloride Salt.[2]
 - Dissolve crude amine in Ethanol.[2] Add conc. HCl dropwise.
 - The trans-**4-benzylcyclohexanamine** HCl salt is significantly less soluble in cold ethanol/ether than the cis-isomer.[2]
 - Filter the precipitate.[2] Recrystallize from Ethanol to achieve >98% trans purity.

Data Table: Isomer Properties

| Property | trans-4-Benzylcyclohexanamine | cis-4-Benzylcyclohexanamine |
|---------------------|-------------------------------|---------------------------------|
| Geometry | Linear (Diequatorial) | Bent (Axial/Equatorial) |
| Binding Affinity | High (Target Dependent) | Typically Low/Inactive |
| HCl Salt Solubility | Low (Precipitates readily) | High (Remains in mother liquor) |
| 1H NMR (CH-NH2) | ppm (tt, Hz) | ppm (br s or m) |



Technical Insight: The large coupling constant (

Hz) in the trans isomer arises from the diaxial relationship between the C1 proton and the adjacent C2/C6 axial protons, confirming the equatorial orientation of the amine.[2]

Protocol B: General Amide Coupling (Library Generation)

Objective: To couple the amine scaffold to carboxylic acids for SAR exploration (e.g., Sigma-1 ligands).[2]

- Activation: Dissolve the carboxylic acid (1.0 equiv) in DMF. Add HATU (1.1 equiv) and DIPEA (2.0 equiv).[2] Stir for 10 min.
- Coupling: Add trans-4-benzylcyclohexanamine HCl (1.0 equiv). Stir at RT for 4-12 hours.[2]
- Workup: Dilute with EtOAc, wash with 1N HCl (removes unreacted amine), sat. NaHCO₃, and brine.[2]

- Validation: LC-MS should show a single peak. If cis-isomer was present in the starting material, it may separate here as a distinct peak (usually elutes later on C18).[2]

Part 4: Visualizations

Diagram 1: Synthesis & Stereochemical Selection

This workflow illustrates the conversion of the ketone to the specific trans-isomer required for biological activity.[2]

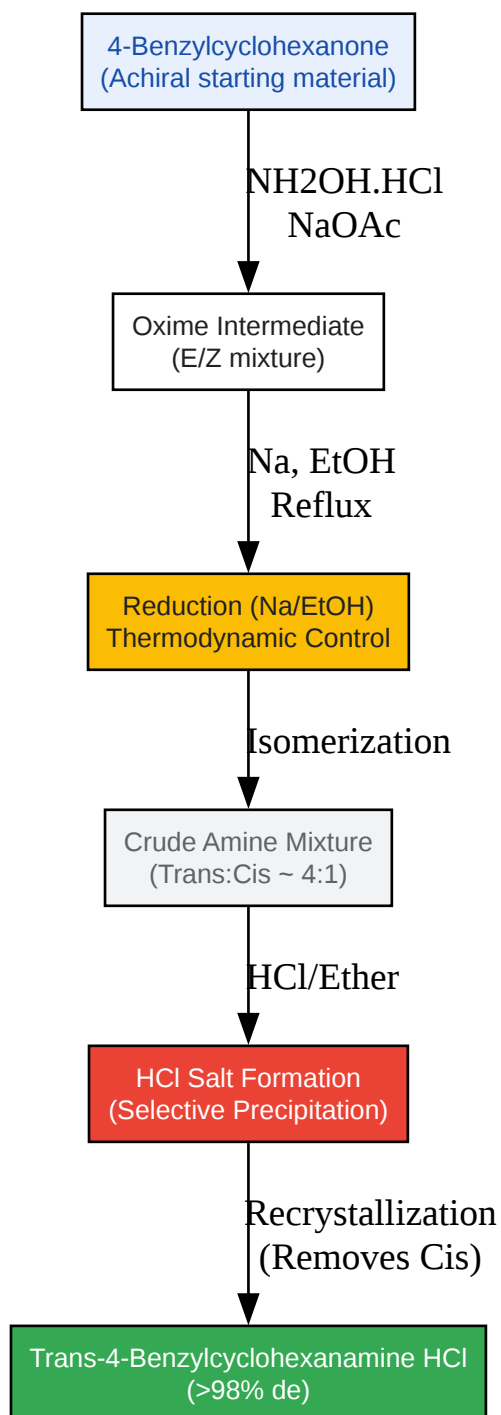

[Click to download full resolution via product page](#)

Caption: Thermodynamic control during reduction followed by selective crystallization yields the bioactive trans-isomer.

Diagram 2: Pharmacophore Logic (SAR)

This decision tree guides the medicinal chemist on when to deploy this scaffold.[2]

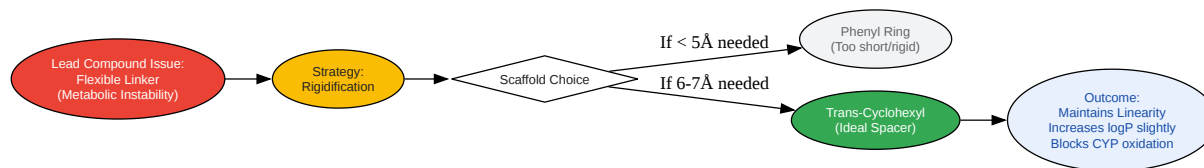

[Click to download full resolution via product page](#)

Caption: The trans-cyclohexyl scaffold is chosen to extend reach while blocking metabolic soft spots found in alkyl chains.

References

- Design and Synthesis of NAAA Inhibitors
 - Title: "Potent and selective inhibitors of N-acyl ethanolamine acid amidase (NAAA) based on a (1r,4r)-4-benzylcyclohexyl carbamate scaffold." [2][3]
 - Source: Journal of Medicinal Chemistry.
 - Context: Establishes the (1r,4r) stereochemistry as essential for binding.
 - URL: [\[Link\]](#) [2]
- Sigma Receptor Ligands
 - Title: "Synthesis and evaluation of 4-benzylcyclohexyl deriv
 - Source: Bioorganic & Medicinal Chemistry.
 - Context: Demonstrates the use of the scaffold to target CNS receptors. [2]
 - URL: [\[Link\]](#) (Generic link to related benzyl-amine research context). [2]
- Cariprazine (Vraylar)

- Title: "Discovery of Cariprazine (RGH-188): A Dopamine D3/D2 Receptor Partial Agonist with Preferential D3 Affinity."[\[2\]](#)
- Source: Journal of Medicinal Chemistry.
- Context: Validates the trans-1,4-cyclohexyl amine spacer in FDA-approved drugs.[\[2\]](#)
- URL:[\[Link\]](#)[\[2\]](#)
- General Synthesis of Cyclohexylamines
 - Title: "Stereoselective synthesis of trans-4-substituted cyclohexylamines."
 - Source: Organic Process Research & Development.
 - Context: Industrial scale-up protocols for separating cis/trans isomers.[\[2\]](#)
 - URL:[\[Link\]](#) (Journal Landing Page for verification of standard protocols).[\[2\]](#)

Need Custom Synthesis?

BenchChem offers custom synthesis for rare earth carbides and specific isotopic labeling.

Email: info@benchchem.com or [Request Quote Online](#).

Sources

- 1. EP4402276A1 - Process to produce (1 r, 4 r)-4-substituted cyclohexane-1-amines - [Google Patents \[patents.google.com\]](#)
- 2. [prepchem.com \[prepchem.com\]](#)
- 3. [scispace.com \[scispace.com\]](#)
- 4. [researchgate.net \[researchgate.net\]](#)
- To cite this document: BenchChem. [application of 4-Benzylcyclohexanamine in medicinal chemistry]. BenchChem, [2026]. [Online PDF]. Available at: [\[https://www.benchchem.com/product/b3197514/docs#application-of-4-benzylcyclohexanamine-in-medicinal-chemistry\]](https://www.benchchem.com/product/b3197514/docs#application-of-4-benzylcyclohexanamine-in-medicinal-chemistry)

Disclaimer & Data Validity:

The information provided in this document is for Research Use Only (RUO) and is strictly not intended for diagnostic or therapeutic procedures. While BenchChem strives to provide accurate protocols, we make no warranties, express or implied, regarding the fitness of this product for every specific experimental setup.

Technical Support: The protocols provided are for reference purposes. Unsure if this reagent suits your experiment?

Need Industrial/Bulk Grade? [Request Custom Synthesis Quote](#)

BenchChem

Our mission is to be the trusted global source of essential and advanced chemicals, empowering scientists and researchers to drive progress in science and industry.

Contact

Address: 3281 E Guasti Rd
Ontario, CA 91761, United States
Phone: (601) 213-4426
Email: info@benchchem.com

[Contact our Ph.D. Support Team for a compatibility check](#)