

Technical Support Center: Catalyst Selection for 3-Bromophenol Cross-Coupling

Author: BenchChem Technical Support Team. **Date:** May 2026

Compound of Interest

Compound Name: 3-(Pyridin-3-yl)phenol

CAS No.: 93851-31-1

Cat. No.: B3195909

[Get Quote](#)

Topic: Optimization of Pd-Catalyzed Cross-Coupling for 3-Bromophenol Substrates Audience: Medicinal Chemists, Process Chemists, and Academic Researchers Status: Active Guide (v2025.1)

Introduction: The "Amphoteric" Challenge

3-Bromophenol represents a deceptive challenge in cross-coupling. While aryl bromides are generally excellent electrophiles, the meta-hydroxyl group introduces two distinct failure modes:

- **Catalyst Poisoning:** Under basic conditions, the phenol deprotonates (pKa ~10). The resulting phenoxide anion is a competent ligand that can coordinate to electrophilic Pd(II) centers, displacing labile phosphines and forming inactive "ate" complexes.
- **Chemoselectivity:** In C-N (Buchwald-Hartwig) couplings, the phenoxide competes as a nucleophile, leading to undesired O-arylation (ether formation) rather than the desired amine.

This guide prioritizes chemoselective systems that operate efficiently even in the presence of the free hydroxyl group, reducing the need for protection/deprotection steps.

Module 1: Suzuki-Miyaura Coupling (C-C Bond Formation)[1]

The Protocol: Direct Coupling of Unprotected Phenols

User Question: I am seeing low conversion (<40%) using Pd(PPh₃)₄ with Na₂CO₃. The reaction turns black immediately. Why?

Root Cause: Pd(PPh₃)₄ is thermally unstable and sensitive to inhibition by phenoxides. The "black" precipitate is Pd(0) aggregation, indicating ligand dissociation.

The Solution: Switch to Bulky, Electron-Rich Dialkylbiaryl Phosphines. Modern precatalysts based on Buchwald ligands (e.g., XPhos, SPhos) are required. These bulky ligands prevent phenoxide coordination to the metal center through steric shielding and facilitate the difficult reductive elimination step.

Recommended Systems

Tier	Catalyst System	Ligand Class	Best For...
Gold Standard	XPhos Pd G4 (0.5–2 mol%)	Dialkylbiaryl Phosphine	Difficult boronic acids, rapid conversion, and sterically hindered partners.
Rugged Workhorse	Pd(dppf)Cl ₂ (2–5 mol%)	Bidentate Ferrocenyl	Standard aryl-aryl couplings; high tolerance for water and air.
Budget/Legacy	Pd(OAc) ₂ + SPhos (1:2 ratio)	Dialkylbiaryl Phosphine	High-throughput screening; SPhos is specifically excellent for phenol tolerance.

Optimized Protocol (Unprotected 3-Bromophenol)

- Solvent: 1,4-Dioxane/Water (4:1). Water is critical for dissolving the inorganic base.

- Base: K_3PO_4 (3.0 equiv). Phosphate is superior to carbonate for buffering the phenol/phenoxide equilibrium.
- Temperature: 80°C.
- Order of Addition: Charge solid reagents (Aryl bromide, Boronic acid, Base, Catalyst)

Evacuate/Backfill N_2 (x3)

Add degassed solvent.

“

Technical Note: If using XPhos Pd G4, the active species is generated immediately upon solution. Do not heat without the substrate present.

Module 2: Buchwald-Hartwig Amination (C-N Bond Formation)[2]

The Protocol: Beating O-Arylation

User Question: I am trying to couple a secondary amine to 3-bromophenol, but I'm getting 30% O-arylation (ether product). How do I stop the phenol from reacting?

Root Cause: The base used to deprotonate the amine (e.g., NaOtBu) also deprotonates the phenol. Without a specific ligand, Reductive Elimination of C-O is often faster than C-N.

The Solution: Ligand-Controlled Selectivity. You must use a ligand that electronically favors the softer amine nucleophile over the harder phenoxide oxygen.

Selection Matrix

Target Nucleophile	Recommended Ligand	Base Selection	Rationale
Primary Amines	BrettPhos	LHMDS or Cs ₂ CO ₃	BrettPhos is highly selective for N-arylation over O-arylation.
Secondary Amines	RuPhos	NaOtBu	RuPhos prevents Pd-O coordination via steric bulk; excellent turnover.
Anilines	tBuBrettPhos	K ₃ PO ₄	Optimized for weaker nucleophiles (anilines) while suppressing phenol interference.

Critical Setup Adjustment

- **Base Stoichiometry:** You must use >2.0 equivalents of base. The first equivalent will be consumed by the phenol. The second equivalent is required to activate the amine/catalyst cycle.
- **Solvent:** t-Amyl alcohol or Toluene (Anhydrous). Avoid water.

Module 3: Troubleshooting & FAQs

Q1: My reaction stalls at 60% conversion. Adding more catalyst doesn't help.

- **Diagnosis:** Product inhibition. The biaryl phenol product might be coordinating to the catalyst more strongly than the starting material.
- **Fix:** Switch to Pd(dtbpf)Cl₂. The di-tert-butyl groups on the ferrocene backbone increase steric bulk, preventing product inhibition. Alternatively, protect the phenol as a MOM (Methoxymethyl) ether before coupling.

Q2: I see significant hydrodebromination (reduction of Br to H).

- Diagnosis: This is often caused by the "hydride shift" from the solvent (especially alcohols) or excessive heating.
- Fix:
 - Switch solvent to THF or Toluene.
 - Use Pd(OAc)₂/CataCXium A. This bulky adamantyl ligand suppresses -hydride elimination pathways that lead to reduction.

Q3: Can I use aryl chlorides instead of bromides?

- Analysis: 3-Chlorophenol is significantly cheaper but much less reactive.
- Recommendation: Yes, but you must use XPhos Pd G4 or BrettPhos Pd G4. Older catalysts like Pd(dppf)Cl₂ will fail with the aryl chloride in the presence of the free hydroxyl group.

Module 4: Decision Logic (Visualization)

The following diagram illustrates the decision process for selecting the optimal catalytic system based on the coupling partner and protection status.

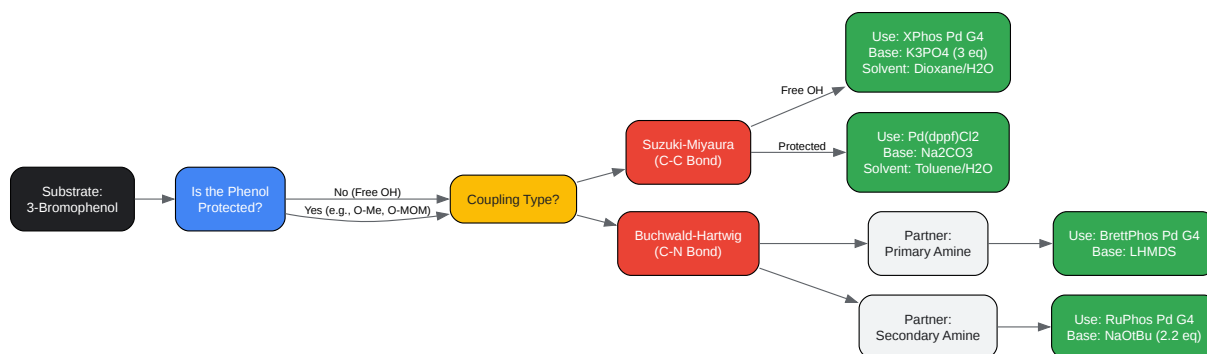

[Click to download full resolution via product page](#)

Caption: Flowchart for selecting the optimal Pd-catalyst system based on substrate protection status and coupling partner type.

References

- Vertex AI Search. (2025). Suzuki-Miyaura coupling of unprotected ortho-bromoanilines and halophenols. National Institutes of Health (NIH). [1](#)[2](#)[3](#)
- Yoneda Labs. (2025). Suzuki-Miyaura Cross-Coupling: Practical Guide and Mechanism. [4](#)[2](#)[3](#)[5](#)[6](#)[7](#)
- BenchChem. (2025). [8](#)[5](#) A Comparative Guide to Base Selection in Suzuki Cross-Coupling Reactions. [5](#)[2](#)[3](#)[5](#)[4](#)
- Bruno, N. C., et al. (2013). Buchwald-Hartwig Amination using Pd G3/G4 Precatalysts. (Contextualized via search results on XPhos/RuPhos utility). [9](#)

- BenchChem. (2025).[5] Comparative Guide to Catalysts for Suzuki-Miyaura Coupling of 4-Amino-3-bromobenzoic Acid. 8[2][3][5][4][10]

Need Custom Synthesis?

BenchChem offers custom synthesis for rare earth carbides and specific isotopic labeling.

Email: info@benchchem.com or [Request Quote Online](#).

Sources

- 1. Suzuki–Miyaura cross-coupling of unprotected ortho-bromoanilines with benzyl, alkyl, aryl, alkenyl and heteroaromatic boronic esters - PMC [[pmc.ncbi.nlm.nih.gov](https://pubmed.ncbi.nlm.nih.gov/)]
- 2. [researchgate.net](https://www.researchgate.net/) [[researchgate.net](https://www.researchgate.net/)]
- 3. [macmillan.princeton.edu](https://www.macmillan.princeton.edu/) [[macmillan.princeton.edu](https://www.macmillan.princeton.edu/)]
- 4. Yoneda Labs [[yonedalabs.com](https://www.yonedalabs.com/)]
- 5. pdf.benchchem.com [pdf.benchchem.com]
- 6. Chemical Insights | How to Wisely Design Conditions for Buchwald-Hartwig Couplings ? - RCS Research Chemistry Services [[rcs.wuxiapptec.com](https://www.rcs.wuxiapptec.com/)]
- 7. trans-Dichlorobis(XPhos)palladium(II) Precatalyst for Suzuki–Miyaura Cross-Coupling Reactions of Aryl/Vinyl Sulfonates/Halides: Scope, Mechanistic Study, and Synthetic Applications - PMC [[pmc.ncbi.nlm.nih.gov](https://pubmed.ncbi.nlm.nih.gov/)]
- 8. pdf.benchchem.com [pdf.benchchem.com]
- 9. pdfs.semanticscholar.org [pdfs.semanticscholar.org]
- 10. [researchgate.net](https://www.researchgate.net/) [[researchgate.net](https://www.researchgate.net/)]
- To cite this document: BenchChem. [Technical Support Center: Catalyst Selection for 3-Bromophenol Cross-Coupling]. BenchChem, [2026]. [Online PDF]. Available at: [<https://www.benchchem.com/product/b3195909/docs#technical-support-center-catalyst-selection-for-3-bromophenol-cross-coupling>]

Disclaimer & Data Validity:

The information provided in this document is for Research Use Only (RUO) and is strictly not intended for diagnostic or therapeutic procedures. While BenchChem strives to provide

accurate protocols, we make no warranties, express or implied, regarding the fitness of this product for every specific experimental setup.

Technical Support: The protocols provided are for reference purposes. Unsure if this reagent suits your experiment?

Need Industrial/Bulk Grade? [Request Custom Synthesis Quote](#)

BenchChem

Our mission is to be the trusted global source of essential and advanced chemicals, empowering scientists and researchers to drive progress in science and industry.

Contact

Address: 3281 E Guasti Rd
Ontario, CA 91761, United States
Phone: (601) 213-4426
Email: info@benchchem.com

[Contact our Ph.D. Support Team for a compatibility check](#)