

Comparative Technical Guide: 3- vs. 4-Hydrazinyl-N,N-Dimethylaniline

Author: BenchChem Technical Support Team. **Date:** April 2026

Compound of Interest

Compound Name: 3-hydrazinyl-N,N-dimethylaniline

CAS No.: 940924-81-2

Cat. No.: B3195934

[Get Quote](#)

Executive Summary: The Isomerism Impact

While sharing an identical molecular formula (

), these two isomers exhibit radically different chemical behaviors driven by resonance topology.^{[1][2]}

- **4-Hydrazinyl-N,N-dimethylaniline (Para):** A "conjugated push-system."^[1] The dimethylamino lone pair is in direct resonance communication with the hydrazine moiety.^[1] This makes the hydrazine terminus highly nucleophilic but susceptible to oxidative degradation (forming quinoid species).^{[1][2]}
- **3-Hydrazinyl-N,N-dimethylaniline (Meta):** An "inductively coupled system."^{[1][2]} The dimethylamino group exerts an electronic influence primarily through induction and weak field effects.^[1] It lacks direct resonance conjugation with the hydrazine, resulting in higher oxidative stability but lower nucleophilicity and complex regioselectivity in cyclization reactions.^[1]

Electronic Structure & Resonance Topology

The defining difference lies in the ability of the dimethylamino () group to delocalize electron density onto the hydrazine () group.[1]

The Para-Isomer (Conjugated)

In the 4-isomer, the

group acts as a strong

-donor (+M effect).[1] This electron density can be delocalized through the benzene ring directly to the hydrazine nitrogen atoms.[1]

- Consequence: The terminal nitrogen (-nitrogen) is significantly more electron-rich.[1]
- Reactivity: Enhanced nucleophilicity toward carbonyls (aldehydes/ketones) but reduced stability in air due to facile oxidation to quinoid-type intermediates.[1][2]

The Meta-Isomer (Non-Conjugated)

In the 3-isomer, the

group is in a meta relationship.[1] Resonance structures cannot place the lone pair charge on the carbon bearing the hydrazine group.[1]

- Consequence: The electronic enrichment is minor (inductive +I effect only).[1][2] The hydrazine group behaves more like a standard phenylhydrazine.[1]
- Reactivity: Standard nucleophilicity; significantly more stable to oxidation; distinct regiochemical outcomes in skeletal rearrangements.[1]

Visualization: Resonance Disparity

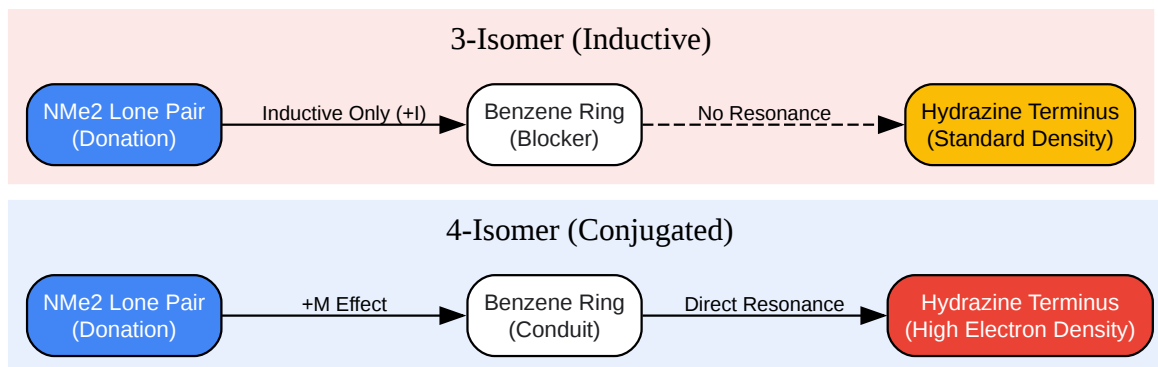

[Click to download full resolution via product page](#)

Figure 1: Resonance topology comparison. The 4-isomer allows direct electron flow to the reactive center, while the 3-isomer blocks it.[1]

Synthesis & Purity Profile

Synthesis Workflows

Both compounds are typically synthesized via the reduction of their corresponding diazonium salts, but the precursors differ in availability and stability.

Feature	4-Hydrazinyl-N,N-dimethylaniline	3-Hydrazinyl-N,N-dimethylaniline
Precursor	4-Amino-N,N-dimethylaniline	3-Amino-N,N-dimethylaniline (from m-nitro)
Diazotization	Standard (, 0°C).[1]	Standard (, 0°C).[1][2]
Reduction	or .[1]	(Stannous chloride method preferred).[1][2]
Isolation	Often isolated as Dihydrochloride salt (Hygroscopic).[1][2]	Often isolated as Free base or Hydrochloride (Oil/Low melting solid).[1][2]
Stability	Low. Oxidizes rapidly in air to dark purple/black tars.[1]	Moderate. More resistant to air oxidation than the para-isomer. [1]

Experimental Protocol: General Reduction (Stannous Chloride Method)

This protocol is adaptable for both isomers, but critical care regarding oxidation applies strictly to the 4-isomer.[1][2]

- **Diazotization:** Dissolve 0.1 mol of the amino-N,N-dimethylaniline isomer in 60 mL conc. HCl. Cool to -5°C. Add dropwise a solution of (7.0 g in 15 mL) while maintaining temp < 0°C.
- **Reduction:** Transfer the cold diazonium solution into a stirred solution of (50 g in 50 mL conc. HCl) at 0°C. Stir for 2 hours.
- **Work-up:**

- For 4-isomer: The hydrochloride salt often precipitates.^[1] Filter under inert gas ().
- For 3-isomer: Basify carefully with NaOH to pH 9 (keep cold), extract with diethyl ether, dry over , and concentrate.
- Storage: Store under Argon at -20°C. The 4-isomer will turn purple upon slight decomposition.

Reactivity Case Study: The Fischer Indole Synthesis

The most critical practical difference for drug discovery chemists is the regioselectivity in the Fischer Indole Synthesis.

The Regioselectivity Trap

When these hydrazines react with an asymmetrical ketone (e.g., ethyl methyl ketone) and undergo acid-catalyzed cyclization:

- 4-Isomer (Para): Symmetric ortho-positions.
 - Outcome: Cyclization can only occur at one type of ortho-carbon.^[1]
 - Product: Exclusively 5-(dimethylamino)indole.^{[1][2]}
- 3-Isomer (Meta): Asymmetric ortho-positions.^{[1][2]}
 - Outcome: Cyclization can occur at C2 (between the hydrazine and) or C6 (para to the).^{[1][2]}
 - Steric/Electronic Rule: Cyclization at the crowded C2 position is sterically disfavored. Cyclization at C6 is favored.^[1]

- Product: Predominantly 6-(dimethylamino)indole, but often accompanied by minor amounts of the 4-isomer (4-dimethylaminoindole).[1][2] Separation of these isomers can be difficult.[1]

Visualization: Fischer Indole Pathways

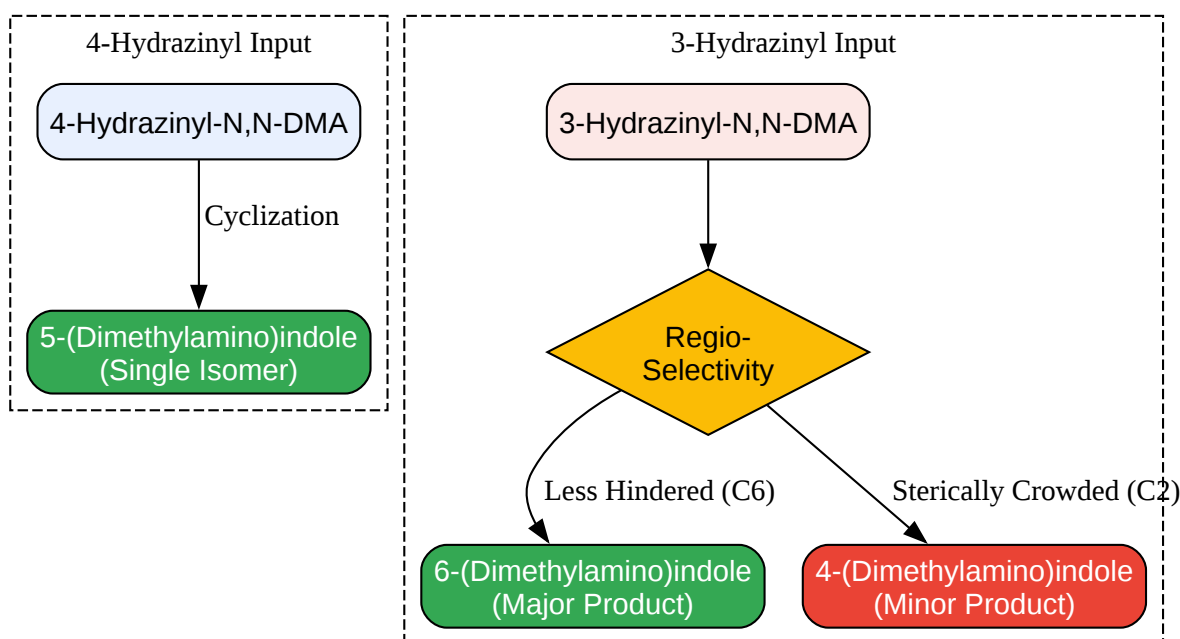

[Click to download full resolution via product page](#)

Figure 2: Regiochemical outcomes in Fischer Indole Synthesis. The 3-isomer introduces a bifurcation in the synthetic pathway.[1]

Applications & Analytical Utility

Application Domain	4-Isomer (Para) Usage	3-Isomer (Meta) Usage
Analytical Chemistry	High. Used to derivatize carbonyls for HPLC/UV detection.[1][2] The conjugated system gives high extinction coefficients (strong UV absorbance).[1][2]	Low. Lower extinction coefficient due to lack of conjugation.[1]
Medicinal Chemistry	Scaffold Synthesis. Access to 5-substituted indole cores (e.g., serotonin analogs).[1][2]	Scaffold Synthesis. Access to 6-substituted indole cores (less common, high IP value).[1][2]
Materials Science	Dyes/Sensors. Precursor for solvatochromic dyes and pH indicators.[1]	Polymer Additives. Used where oxidative stability is required over optical properties.[1]

Safety & Toxicology

Warning: All hydrazine derivatives are potential carcinogens and skin sensitizers.[1]

- General Hazard: Both isomers are toxic by inhalation, ingestion, and skin contact.[1]
- Specific Hazard (4-Isomer): Due to its ease of oxidation, the 4-isomer can generate quinoid iminium ions in vivo or in solution.[1] These electrophilic species can alkylate DNA more aggressively than the metabolites of the 3-isomer.[1]
- Handling: Always handle in a fume hood. Use double nitrile gloves.[1] Decontaminate glassware with bleach (sodium hypochlorite) to oxidize residual hydrazine to nitrogen gas before washing.[1][2]

References

- Robinson, B. (1982).[1][2] The Fischer Indole Synthesis. Wiley-Interscience.[1] (Definitive text on regioselectivity mechanisms).
- Hughes, D. L. (1993).[1][2] "The Fischer Indole Synthesis." [1][3][4][5] Organic Preparations and Procedures International, 25(6), 607-632.[1] [Link](#)[1][2]

- Smith, P. A. S. (1983).[1][2] Derivatives of Hydrazine and Other Hydronitrogens Having N-N Bonds. Benjamin/Cummings.[1] (Source for electronic properties of hydrazines).[1][2]
- Liu, Y., et al. (2010).[1] "Regioselectivity in the Fischer Indole Synthesis: Electronic and Steric Effects." Journal of Organic Chemistry, 75(15), 5000-5007.[1] (Specific discussion on meta-substituted hydrazines).

Need Custom Synthesis?

BenchChem offers custom synthesis for rare earth carbides and specific isotopic labeling.

Email: info@benchchem.com or [Request Quote Online](#).

Sources

- 1. 4-Dimethylaminopyridine - Wikipedia [en.wikipedia.org]
- 2. pKa values bases - Chair of Analytical Chemistry [analytical.chem.ut.ee]
- 3. Fischer indole synthesis - Wikipedia [en.wikipedia.org]
- 4. pdf.benchchem.com [pdf.benchchem.com]
- 5. (PDF) Synthesis of New 2-Substituted Phenyl-1H-Indoles via Fischer Indole Reaction [academia.edu]
- To cite this document: BenchChem. [Comparative Technical Guide: 3- vs. 4-Hydrazinyl-N,N-Dimethylaniline]. BenchChem, [2026]. [Online PDF]. Available at: [<https://www.benchchem.com/product/b3195934/docs#comparative-technical-guide-3-vs-4-hydrazinyl-n-n-dimethylaniline>]

Disclaimer & Data Validity:

The information provided in this document is for Research Use Only (RUO) and is strictly not intended for diagnostic or therapeutic procedures. While BenchChem strives to provide accurate protocols, we make no warranties, express or implied, regarding the fitness of this product for every specific experimental setup.

Technical Support: The protocols provided are for reference purposes. Unsure if this reagent suits your experiment?

Need Industrial/Bulk Grade? [Request Custom Synthesis Quote](#)

BenchChem

Our mission is to be the trusted global source of essential and advanced chemicals, empowering scientists and researchers to drive progress in science and industry.

Contact

Address: 3281 E Guasti Rd
Ontario, CA 91761, United States
Phone: (601) 213-4426
Email: info@benchchem.com

[Contact our Ph.D. Support Team for a compatibility check](#)