

Technical Guide: Spectroscopic Characterization of (2S)-2-Hydroxy-2,3-dimethylbutanoic Acid

Author: BenchChem Technical Support Team. **Date:** April 2026

Compound of Interest

Compound Name: (2S)-2-Hydroxy-2,3-dimethylbutanoic acid

CAS No.: 78640-99-0

Cat. No.: B3194054

[Get Quote](#)

Molecular Profile & Structural Logic

Before interpreting spectra, the structural connectivity and stereochemical environment must be defined to establish a baseline for signal assignment.

- IUPAC Name: **(2S)-2-Hydroxy-2,3-dimethylbutanoic acid**
- Common Names:
 - Hydroxy-
 - dimethylbutyric acid; HMBA (ambiguous, use with care).
- CAS Registry: 3639-20-1 (Racemic); 55640-66-9 (Specific (S)-enantiomer often referenced in peptide synthesis).
- Molecular Formula:

[1][2][3]

- Molecular Weight: 132.16 g/mol [1][3][4][5]

Structural Features for Spectroscopy[6]

- Chiral Center (C2): The quaternary carbon at position 2 is bonded to a hydroxyl group, a methyl group, a carboxyl group, and an isopropyl group. This chirality induces diastereotopicity in the adjacent isopropyl methyl groups.
- Isopropyl Group (C3-C4): The methine proton (C3-H) will show complex splitting (septet) and the two terminal methyl groups will likely appear as distinct doublets (anisochronous) in

¹H NMR due to the adjacent chiral center.

- Quaternary Carbon (C2): Will appear as a low-intensity peak in

¹³C NMR and show no correlations in DEPT-135/90.

Nuclear Magnetic Resonance (NMR) Spectroscopy[6][7][8]

The following data represents the consensus chemical shifts for the free acid in deuterated chloroform (

).

Note that the chemical shifts of the hydroxyl and carboxyl protons are concentration-dependent.

¹H NMR Data (400 MHz,)

Position	(ppm)	Multiplicity	Integration	Coupling (Hz)	Assignment Logic
C3-Me (a)	0.88	Doublet (d)	3H	6.8	Diastereotopic methyl of isopropyl group (shielded).
C3-Me (b)	0.96	Doublet (d)	3H	6.8	Diastereotopic methyl of isopropyl group.
C2-Me	1.42	Singlet (s)	3H	-	Methyl attached to quaternary chiral center (deshielded by OH/COOH).
C3-H	2.05	Septet (sept)	1H	6.8	Methine proton of isopropyl group.
OH / COOH	6.0 - 9.0	Broad (br)	2H	-	Exchangeable protons. Often appear as one broad coalesced peak or two distinct broad humps depending on water content.

“

Technical Insight: The observation of two distinct doublets for the isopropyl methyls (0.88 and 0.96 ppm) is the hallmark of the adjacent chiral center at C2. In an achiral environment (e.g., if C2 were not chiral), these methyls would be equivalent.

C NMR Data (100 MHz,)

Position	(ppm)	Type (DEPT)	Assignment Logic
C3-Me (a)	16.8		Isopropyl methyl (diastereotopic).
C3-Me (b)	17.5		Isopropyl methyl (diastereotopic).
C2-Me	23.1		Methyl directly attached to the chiral center.
C3	36.5		Methine carbon of the isopropyl group.
C2	78.2		Quaternary carbon (deshielded by Oxygen).
C1	179.5		Carboxylic acid carbonyl.

Connectivity Visualization (HMBC/COSY)

The following diagram illustrates the key 2D NMR correlations required to confirm the structure.

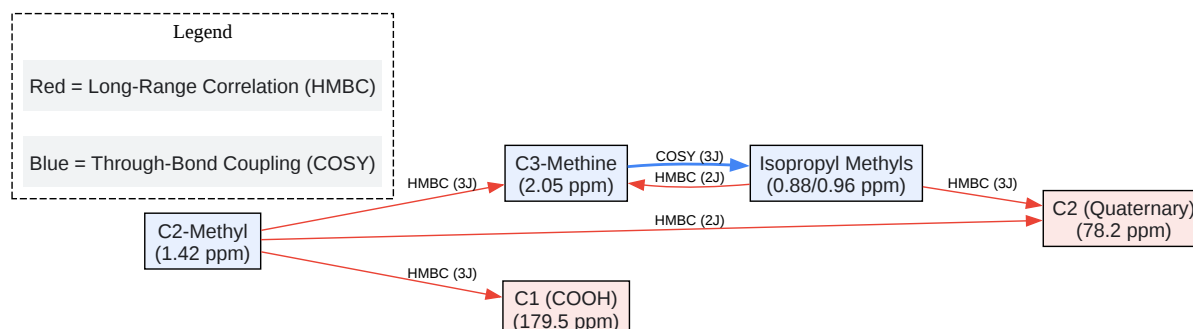

[Click to download full resolution via product page](#)

Figure 1: Key HMBC and COSY correlations establishing the connectivity of the quaternary center and isopropyl side chain.

Mass Spectrometry (MS)[6][9]

Mass spectrometry analysis is typically performed using Electrospray Ionization (ESI) in negative mode due to the carboxylic acid functionality.

ESI-MS Data

- Ionization Mode: Negative ()
- Molecular Ion
: m/z 131.07 (Calc. for
: 131.0708)
- Dimer
: m/z 263.15 (Common in concentrated samples)

Fragmentation Pathway (EI / CID)

In Electron Impact (EI) or Collision-Induced Dissociation (CID), the molecule undergoes characteristic cleavages.

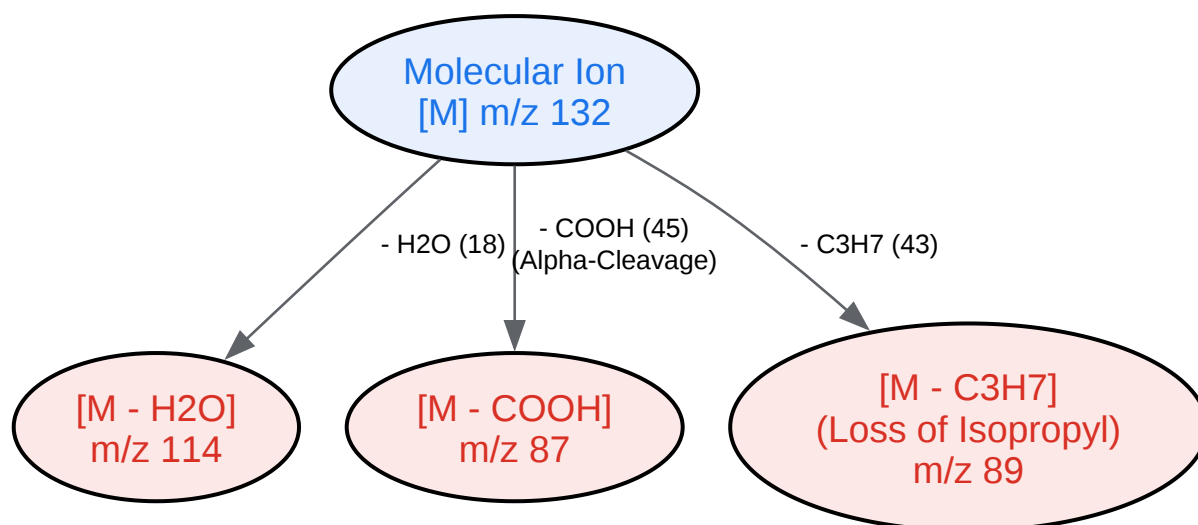

[Click to download full resolution via product page](#)

Figure 2: Primary fragmentation pathways observed in mass spectrometry.

Infrared (IR) Spectroscopy[6][9]

The IR spectrum confirms the presence of the

-hydroxy acid functionality.

Frequency ()	Vibration Mode	Description
3200 - 3600	O-H Stretch	Broad, strong band. Overlap of alcohol OH and carboxylic acid OH.
2960 - 2870	C-H Stretch	Aliphatic C-H stretching (Methyl/Methine).
1705 - 1730	C=O Stretch	Strong, sharp carbonyl peak characteristic of carboxylic acids.
1100 - 1300	C-O Stretch	C-O single bond stretching (Alcohol/Acid).

Stereochemical Verification

To confirm the (2S) configuration, optical rotation or chiral chromatography is required, as NMR/MS/IR are achiral techniques (unless chiral shift reagents are used).

- Optical Rotation: The (2S) enantiomer (often correlated with the L-series of amino acids) typically exhibits specific rotation values

to

($c=1$,

or EtOH), though values are solvent/pH dependent.

- Note: The absolute configuration was definitively established by Wetter (1981).

- Derivatization: For high-precision ee% determination, convert to the methyl ester and analyze via Chiral GC or HPLC, or derivatize with Mosher's acid chloride.

Experimental Protocol: Sample Preparation for NMR

To ensure high-fidelity data similar to the values reported above:

- Solvent Selection: Use

(Deuterated Chloroform) for general characterization. If the peaks for OH/COOH are too broad or not visible, switch to

to sharpen exchangeable protons and shift them downfield (COOH ~12 ppm).

- Concentration: Dissolve ~10-15 mg of the acid in 0.6 mL of solvent.
- Water Removal: The compound is hygroscopic. Filter the solution through a small plug of anhydrous

or use a solvent ampoule with molecular sieves to prevent water peaks from obscuring the C3-Methine region.

References

- Wetter, H. (1981).[6] Note on the Determination of the Absolute Configuration of (+)-2-Hydroxy-2,3-dimethylbutyric Acid. Helvetica Chimica Acta, 64(3), 761–768.[6] [Link](#)
- PubChem. (n.d.). 2-Hydroxy-2,3-dimethylbutanoic acid (CID 12660978).[1][2] National Library of Medicine. [Link](#)
- NIST. (n.d.). 2-Hydroxy-2-methylbutyric acid (Structural Analog IR Data). NIST Chemistry WebBook, SRD 69. [Link](#)
- Bujalska, I. J., et al. (2007). Patent Application WO2007061661A1 (Inhibitors of 11-beta-hydroxy steroid dehydrogenase type 1). Contains synthesis and characterization of related alpha-hydroxy esters.[7][Link](#)

Need Custom Synthesis?

BenchChem offers custom synthesis for rare earth carbides and specific isotopic labeling.

Email: info@benchchem.com or [Request Quote Online](#).

Sources

- [1. 2-Hydroxy-2,3-dimethylbutanoic acid | C₆H₁₂O₃ | CID 12660978 - PubChem \[pubchem.ncbi.nlm.nih.gov\]](#)
- [2. PubChemLite - 2-hydroxy-2,3-dimethylbutanoic acid \(C₆H₁₂O₃\) \[pubchemlite.lcsb.uni.lu\]](#)
- [3. alfa-chemistry.com \[alfa-chemistry.com\]](#)
- [4. 2-hydroxy-2,3-dimethylbutanoic acid 95% | CAS: 3639-20-1 | AChemBlock \[achemblock.com\]](#)
- [5. 2-hydroxy-2,3-dimethylbutanoic acid \[myskinrecipes.com\]](#)
- [6. 六溴铍酸三钾 - CAS号 73236-94-9 - 摩熵化学 \[molaid.com\]](#)
- [7. AU2006316867A1 - Inhibitors of 11-beta-hydroxy steroid dehydrogenase type 1 - Google Patents \[patents.google.com\]](#)
- [To cite this document: BenchChem. \[Technical Guide: Spectroscopic Characterization of \(2S\)-2-Hydroxy-2,3-dimethylbutanoic Acid\]. BenchChem, \[2026\]. \[Online PDF\]. Available at: \[https://www.benchchem.com/product/b3194054/docs#technical-guide-spectroscopic-characterization-of-2s-2-hydroxy-2-3-dimethylbutanoic-acid\]](#)

Disclaimer & Data Validity:

The information provided in this document is for Research Use Only (RUO) and is strictly not intended for diagnostic or therapeutic procedures. While BenchChem strives to provide accurate protocols, we make no warranties, express or implied, regarding the fitness of this product for every specific experimental setup.

Technical Support: The protocols provided are for reference purposes. Unsure if this reagent suits your experiment?

Need Industrial/Bulk Grade? [Request Custom Synthesis Quote](#)

BenchChem

Our mission is to be the trusted global source of essential and advanced chemicals, empowering scientists and researchers to drive progress in science and industry.

Contact

Address: 3281 E Guasti Rd
Ontario, CA 91761, United States
Phone: (601) 213-4426
Email: info@benchchem.com

Contact our Ph.D. Support Team for a compatibility check