

Technical Comparison Guide: GC-MS Fragmentation of Pyrrolidine-1-valeronitrile Isomers

Author: BenchChem Technical Support Team. **Date:** May 2026

Compound of Interest

Compound Name: *Pyrrolidine-1-valeronitrile*

CAS No.: 71888-57-8

Cat. No.: B3193450

[Get Quote](#)

Executive Summary

Pyrrolidine-1-valeronitrile ($C_9H_{16}N_2$) is a critical intermediate in the synthesis of pyrrolidinophenone-type designer drugs (e.g.,

-PVP) and a potential impurity in pharmaceutical raw materials. However, the nomenclature often conflates two distinct structural isomers: the linear 5-(pyrrolidin-1-yl)pentanenitrile and the branched

-aminonitrile precursor, 2-(pyrrolidin-1-yl)pentanenitrile.

This guide provides a definitive technical comparison of their GC-MS fragmentation patterns. By analyzing the mechanistic pathways—specifically the competition between alkyl elimination and nitrile elimination—we establish diagnostic ions that allow researchers to unambiguously differentiate these isomers in complex matrices.

Chemical Identity & Structural Basis[1][2][3][4][5][6]

The distinct fragmentation behavior of these isomers arises from the position of the pyrrolidine ring relative to the nitrile group and the alkyl chain.

Feature	Isomer A: Linear (Standard)	Isomer B: Branched (Precursor)
IUPAC Name	5-(pyrrolidin-1-yl)pentanenitrile	2-(pyrrolidin-1-yl)pentanenitrile
Structure	Pyrrolidine- -(CH ₂) ₄ -CN	Pyrrolidine- -CH(CN)-C ₃ H ₇
Role	Industrial intermediate, degradation product	Precursor to -PVP (Strecker synthesis product)
Key Lability	-carbon (exocyclic)	-carbon (branched center)

Experimental Protocol (GC-EI-MS)

To ensure reproducibility of the fragmentation patterns described below, the following instrument parameters are recommended. These conditions minimize thermal degradation while maximizing ionization efficiency.

Gas Chromatography

- Column: Rxi-5Sil MS or equivalent (30 m × 0.25 mm ID, 0.25 μm film thickness).
- Carrier Gas: Helium at 1.0 mL/min (constant flow).
- Inlet Temperature: 250°C (Splitless mode recommended for trace analysis).
- Temperature Program:
 - Initial: 60°C (hold 1 min).
 - Ramp: 20°C/min to 280°C.
 - Final: 280°C (hold 5 min).

Mass Spectrometry

- Ionization: Electron Ionization (EI) at 70 eV.[1]
- Source Temperature: 230°C.
- Quadrupole Temperature: 150°C.
- Scan Range:m/z 40–350.
- Solvent Delay: 3.0 min (to exclude solvent tail).

Fragmentation Analysis

A. Linear Isomer: 5-(pyrrolidin-1-yl)pentanenitrile

Dominant Mechanism:

-Cleavage of the Exocyclic Alkyl Chain.

In linear

-alkyl pyrrolidines, the ionization occurs at the nitrogen lone pair. The radical cation stabilizes itself by cleaving the C-C bond adjacent to the

-carbon (the carbon attached to the nitrogen).

- Pathway: The bond between C1 (attached to N) and C2 of the pentyl chain breaks.

- Resulting Ion: The

-methylene pyrrolidinium ion (

84).

- Diagnostic Value: This ion is the base peak (100% abundance) for almost all linear

-alkyl pyrrolidines with a chain length

2 carbons.

Secondary Ions:

- 42: Ring fragmentation ($C_2H_4N^+$).
- 55: $C_4H_7^+$ fragment from the alkyl chain.
- 152 (M^+): Typically weak (<5%) due to the rapid
-cleavage.

B. Branched Isomer: 2-(pyrrolidin-1-yl)pentanenitrile

Dominant Mechanism: Nitrile Elimination vs. Alkyl Elimination.

The branched isomer is an

-aminonitrile. The molecular ion is extremely unstable. Fragmentation is driven by the loss of the groups attached to the tertiary carbon (

-carbon).

- Pathway 1 (Dominant): Loss of Cyano Group (-CN).
 - The loss of the electron-withdrawing nitrile radical (26 Da) is energetically favored because the resulting carbocation is resonance-stabilized by the adjacent nitrogen lone pair and the propyl chain.
 - Fragment:
-butylidene-pyrrolidinium ion.
 - Mass Calculation:
.
 - Significance: This
126 ion is structurally identical to the iminium ion observed in the fragmentation of
-PVP, making it a definitive marker for the "drug precursor" structure.

- Pathway 2: Loss of Propyl Group (-C₃H₇).

- Loss of the alkyl chain (43 Da) yields the cyano-iminium ion.

- Mass Calculation:

.

- Abundance: Generally lower than

126 because the cyano group destabilizes the adjacent positive charge relative to the propyl group.

Visualized Fragmentation Pathways[8][9]

The following diagram illustrates the divergent pathways that allow for isomer differentiation.

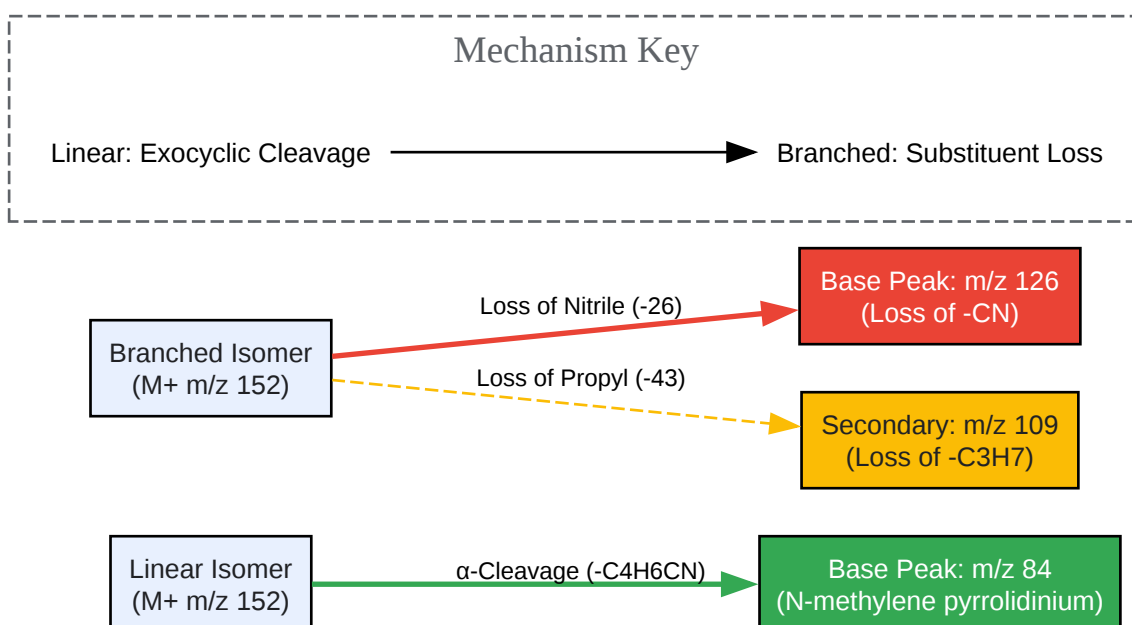

[Click to download full resolution via product page](#)

Caption: Divergent fragmentation pathways for Linear vs. Branched isomers. Green indicates the diagnostic pathway for the linear impurity; Red indicates the diagnostic pathway for the drug precursor.

Comparative Data Summary

Use this table to interpret GC-MS data when analyzing unknown samples suspected to contain pyrrolidine-valeronitrile analogs.

Parameter	Linear Isomer	Branched Isomer
Base Peak (100%)	84	126
Diagnostic Ion 2	55 (Alkyl chain)	109 (M - Propyl)
Diagnostic Ion 3	42 (Ring fragment)	84 (Secondary rearrangement)
Molecular Ion (152)	Trace / Absent	Trace / Absent
Mechanism	Standard amine -cleavage	Nitrile/Alkyl elimination
Interpretation	Negative for Precursor	Positive for Precursor

Analyst Note: The "126" Trap

The

126 ion is highly specific to the 1-phenyl-2-(1-pyrrolidinyl) structural motif found in

-PVP and its precursors. If you observe a peak at

126 in a nitrile sample, it confirms the branched structure (2-position substitution). If the spectrum is dominated by

84 with no significant 126 or 109 peaks, the substance is the linear isomer, likely an artifact or unrelated impurity.

References

- NIST Mass Spectrometry Data Center. (2023). Mass Spectrum of 1-Pyrrolidinebutyronitrile (CAS 35543-25-0). National Institute of Standards and Technology.[2][3] [\[Link\]](#)

- McLafferty, F. W., & Tureček, F. (1993). Interpretation of Mass Spectra (4th ed.). University Science Books. (Standard reference for amine -cleavage mechanisms).
- Scientific Working Group for the Analysis of Seized Drugs (SWGDRUG). (2023). Mass Spectral Library - Version 3.11. [\[Link\]](#)
- Brandt, S. D., et al. (2010).

Need Custom Synthesis?

BenchChem offers custom synthesis for rare earth carbides and specific isotopic labeling.

Email: info@benchchem.com or [Request Quote Online](#).

Sources

- 1. cfsre.org [cfsre.org]
- 2. 1-Piperidineacetonitrile [webbook.nist.gov]
- 3. Pentanenitrile [webbook.nist.gov]
- To cite this document: BenchChem. [Technical Comparison Guide: GC-MS Fragmentation of Pyrrolidine-1-valeronitrile Isomers]. BenchChem, [2026]. [Online PDF]. Available at: [<https://www.benchchem.com/product/b3193450/docs#technical-comparison-guide-gc-ms-fragmentation-of-pyrrolidine-1-valeronitrile-isomers>]

Disclaimer & Data Validity:

The information provided in this document is for Research Use Only (RUO) and is strictly not intended for diagnostic or therapeutic procedures. While BenchChem strives to provide accurate protocols, we make no warranties, express or implied, regarding the fitness of this product for every specific experimental setup.

Technical Support: The protocols provided are for reference purposes. Unsure if this reagent suits your experiment?

Need Industrial/Bulk Grade? [Request Custom Synthesis Quote](#)

BenchChem

Our mission is to be the trusted global source of essential and advanced chemicals, empowering scientists and researchers to drive progress in science and industry.

Contact

Address: 3281 E Guasti Rd

Ontario, CA 91761, United States

Phone: (601) 213-4426

Email: info@benchchem.com

[Contact our Ph.D. Support Team for a compatibility check](#)