

# Technical Support Center: Troubleshooting Grignard-Based Thiophene Reactions

**Author:** BenchChem Technical Support Team. **Date:** April 2026

## Compound of Interest

Compound Name: 3-Formylthiophene-2-carbonitrile

CAS No.: 41056-99-9

Cat. No.: B3190337

[Get Quote](#)

Welcome to the Advanced Application Support Center. This guide provides mechanistic troubleshooting, quantitative analytics, and self-validating protocols for Grignard-based thiophene functionalization. Designed for researchers and drug development professionals, this resource focuses on resolving byproduct formation in Kumada cross-coupling and Grignard Metathesis (GRIM) polymerization.

## Part 1: Diagnostic Workflows

Understanding the mechanistic divergence between desired product formation and byproduct generation is the first step in troubleshooting. The diagrams below illustrate the critical pathways in thiophene functionalization.

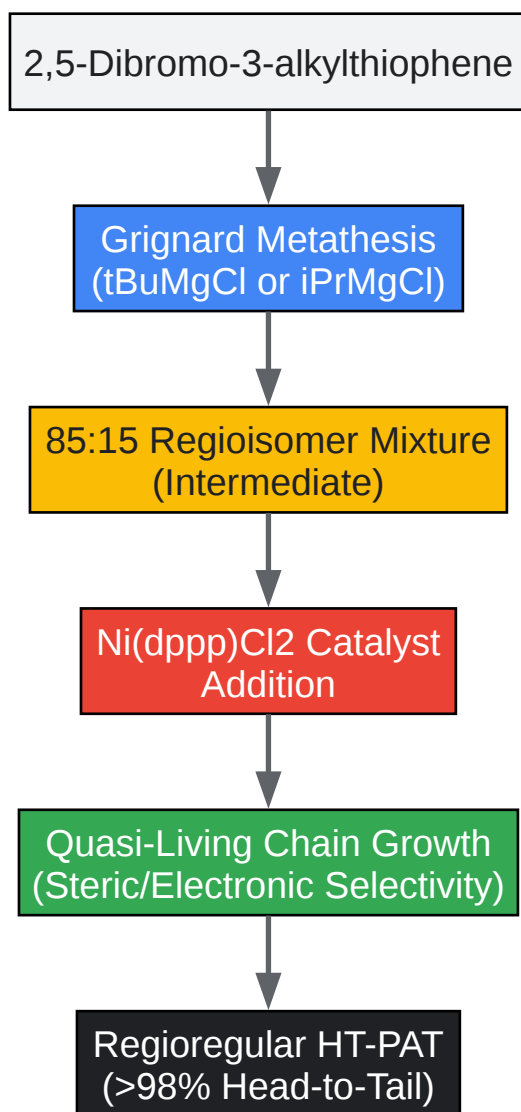

[Click to download full resolution via product page](#)

Fig 1: Mechanistic pathway of GRIM polymerization for regioregular polythiophenes.

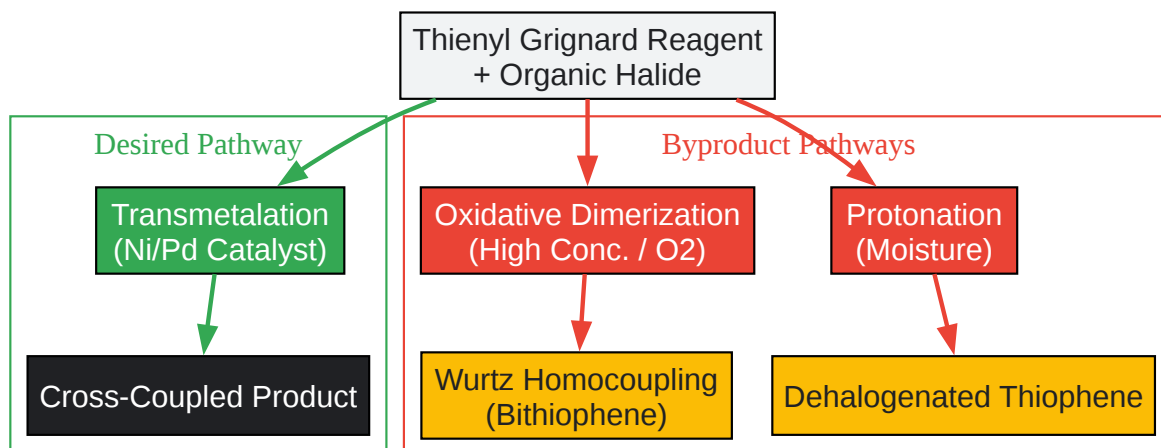

[Click to download full resolution via product page](#)

Fig 2: Divergent pathways showing desired cross-coupling vs. byproduct formation.

## Part 2: Mechanistic Q&A and Troubleshooting

Q1: I am observing a significant amount of homocoupled (Wurtz) bithiophene byproducts during my Kumada cross-coupling. What is the mechanistic cause, and how can I prevent it?

Causality: Homocoupling (Wurtz-type coupling) is a frequent side reaction in Grignard-based cross-couplings[1]. Mechanistically, this occurs when high local concentrations of the thienyl Grignard reagent lead to oxidative dimerization, or when two Grignard molecules undergo transmetalation at the same metal center prior to reductive elimination[2]. Solution: To prevent this, the Grignard reagent must be added dropwise to maintain a low steady-state concentration, and the reaction temperature should be strictly controlled to suppress the bimolecular side reaction[1]. Furthermore, utilizing a bidentate phosphine ligand like dppp (1,3-bis(diphenylphosphino)propane) enforces a rigid geometry on the catalyst, enhancing selectivity toward the desired cross-coupled product[2].

Q2: During the GRIM polymerization of 3-hexylthiophene, my polymer exhibits low regioregularity (high Tail-to-Tail defects). How do I ensure >98% Head-to-Tail (HT) coupling?

Causality: This is the gold standard for synthesizing regioregular poly(3-alkylthiophenes)[3]. During the initial metathesis of 2,5-dibromo-3-alkylthiophene, an 85:15 mixture of two regioisomers is formed regardless of the temperature or Grignard reagent used[3]. Despite this

imperfect monomer pool, the addition of the Ni(dppp)Cl<sub>2</sub> catalyst yields polymers with >95% HT couplings[3]. This high regioselectivity is driven by a , where the nickel catalyst exhibits strong kinetic and thermodynamic selectivity for the less sterically hindered isomer[4]. Solution: If your polymer exhibits high Tail-to-Tail (TT) defects, it is typically due to catalyst degradation or the use of an incorrect ligand (e.g., a monodentate phosphine) that fails to enforce this vital steric selectivity[3]. Ensure your Ni(dppp)Cl<sub>2</sub> is stored in a desiccator and use fresh catalyst for each run.

Q3: My metalation of halogenated thiophenes is yielding alkyl-addition byproducts instead of the desired metalated species. Should I switch reagents? Causality: When attempting to metalate halogenated thiophenes, researchers sometimes use organolithium reagents (e.g., n-BuLi). However, in solvents like THF, n-BuLi can be overly reactive, leading to undesired alkyl addition (e.g., butylated thiophenes) rather than clean halogen-metal exchange[5]. Solution: for their chemoselectivity and functional group tolerance[5]. Switching to iPrMgCl or tBuMgCl will facilitate a clean magnesium-halogen exchange without nucleophilic attack on the thiophene ring.

## Part 3: Quantitative Data Analytics

The following table summarizes the impact of various reaction parameters on the yield of desired products versus common byproducts in Kumada coupling.

Reaction Parameter	Desired Cross-Coupling Yield (%)	Wurtz Homocoupling Yield (%)	Dehalogenation Yield (%)
Rapid Grignard Addition (Bolus)	65.0	25.0	10.0
Dropwise Grignard Addition	92.0	< 5.0	< 3.0
Elevated Temperature (Reflux)	70.0	20.0	10.0
Controlled Temperature (0–25 °C)	89.0	6.0	5.0
Monodentate Ligand (e.g., PPh <sub>3</sub> )	55.0	30.0	15.0
Bidentate Ligand (e.g., dppp)	95.0	< 2.0	< 3.0

Data synthesized from benchmark Kumada coupling optimizations.

## Part 4: Self-Validating Experimental Protocols

### Protocol 1: Grignard Metathesis (GRIM) Polymerization of Regioregular P3HT

Objective: Synthesize poly(3-hexylthiophene) with >98% Head-to-Tail (HT) regioregularity while preventing premature dehalogenation.

- Monomer Activation: Dissolve 2,5-dibromo-3-hexylthiophene (1.0 equiv) in anhydrous THF under a strict argon atmosphere. Add tBuMgCl (1.0 equiv) dropwise at room temperature.
  - Causality: tBuMgCl is sterically hindered, preventing its own cross-coupling, thus exclusively driving the magnesium-halogen exchange.

- Validation Checkpoint: The solution will exhibit a mild exotherm. After 1 hour, quench a 0.1 mL aliquot in water and analyze via GC-MS. The system is validated to proceed ONLY if the mass corresponding to monobromo-hexylthiophene is >95%. If unreacted dibromide remains, verify the Grignard titer.
- Catalyst Initiation: Add Ni(dppp)Cl<sub>2</sub> (0.5 mol%) in one portion to the reaction mixture.
  - Causality: The bidentate dppp ligand enforces a strict square-planar geometry on the nickel center, which is critical for the steric recognition required to select the correct regioisomer during chain growth.
  - Validation Checkpoint: Within 5–10 minutes, the solution must transition from pale yellow to a deep, opaque red/purple. This color change confirms the formation of the active Ni-polymer chain end. If the solution remains pale, the catalyst is poisoned (check for moisture/oxygen).
- Chain Growth and Termination: Reflux the mixture for 2 hours, then pour rapidly into cold methanol.
  - Validation Checkpoint: A dark purple solid should precipitate immediately. A lack of precipitate indicates premature termination during the metathesis step.

## Protocol 2: Controlled Kumada Cross-Coupling of 3-Bromothiophene

Objective: Couple 3-bromothiophene with an aryl Grignard reagent while completely suppressing Wurtz homocoupling.

- Catalyst Preparation: Suspend Ni(dppp)Cl<sub>2</sub> (1.0 mol%) and 3-bromothiophene (1.0 equiv) in anhydrous THF at 0 °C.
- Controlled Transmetalation: Load the aryl Grignard reagent (1.1 equiv) into a syringe pump. Add dropwise at a rate of 0.1 equiv/min.
  - Causality: Maintaining a low steady-state concentration of the Grignard reagent prevents two organomagnesium species from simultaneously populating the nickel center, thereby shutting down the oxidative dimerization pathway.

- Validation Checkpoint: The reaction temperature must not exceed 5 °C during addition. Monitor the internal temperature; if it spikes, pause the addition immediately to prevent thermal homocoupling.
- Reaction Completion: Allow the mixture to warm to room temperature and stir for 2 hours.
  - Validation Checkpoint: Quench an aliquot with 1M HCl. TLC (Hexanes:EtOAc) should show complete consumption of the 3-bromothiophene spot. If the starting material persists, the Grignard reagent was likely quenched by adventitious moisture.

## References

- Title: Regioregular, Head-to-Tail Coupled Poly(3-alkylthiophenes) Made Easy by the GRIM Method: Investigation of the Reaction and the Origin of Regioselectivity Source: Macromolecules - ACS Publications URL:[[Link](#)]
- Title: Experimental Evidence for the Quasi-“Living” Nature of the Grignard Metathesis Method for the Synthesis of Regioregular Poly(3-alkylthiophenes) Source: Macromolecules - ACS Publications URL:[[Link](#)]
- Title: Development of potential manufacturing routes for substituted thiophenes Source: Beilstein Journal of Organic Chemistry URL:[[Link](#)]

### *Need Custom Synthesis?*

*BenchChem offers custom synthesis for rare earth carbides and specific isotopic labeling.*

*Email: [info@benchchem.com](mailto:info@benchchem.com) or [Request Quote Online](#).*

## Sources

- 1. [pdf.benchchem.com](https://pdf.benchchem.com) [[pdf.benchchem.com](https://pdf.benchchem.com)]
- 2. [benchchem.com](https://benchchem.com) [[benchchem.com](https://benchchem.com)]
- 3. [pubs.acs.org](https://pubs.acs.org) [[pubs.acs.org](https://pubs.acs.org)]
- 4. [chem.cmu.edu](https://chem.cmu.edu) [[chem.cmu.edu](https://chem.cmu.edu)]

- 5. Development of potential manufacturing routes for substituted thiophenes – Preparation of halogenated 2-thiophenecarboxylic acid derivatives as building blocks for a new family of 2,6-dihaloaryl 1,2,4-triazole insecticides [beilstein-journals.org]
- To cite this document: BenchChem. [Technical Support Center: Troubleshooting Grignard-Based Thiophene Reactions]. BenchChem, [2026]. [Online PDF]. Available at: [https://www.benchchem.com/product/b3190337/docs#technical-support-center-troubleshooting-grignard-based-thiophene-reactions]

---

### Disclaimer & Data Validity:

The information provided in this document is for Research Use Only (RUO) and is strictly not intended for diagnostic or therapeutic procedures. While BenchChem strives to provide accurate protocols, we make no warranties, express or implied, regarding the fitness of this product for every specific experimental setup.

**Technical Support:** The protocols provided are for reference purposes. Unsure if this reagent suits your experiment?

**Need Industrial/Bulk Grade?** [Request Custom Synthesis Quote](#)

## BenchChem

Our mission is to be the trusted global source of essential and advanced chemicals, empowering scientists and researchers to drive progress in science and industry.

### Contact

Address: 3281 E Guasti Rd  
Ontario, CA 91761, United States  
Phone: (601) 213-4426  
Email: [info@benchchem.com](mailto:info@benchchem.com)

[Contact our Ph.D. Support Team for a compatibility check](#)

