

# Technical Support Center: Mastering cis-Selectivity in Aminoindanol Synthesis

**Author:** BenchChem Technical Support Team. **Date:** April 2026

## Compound of Interest

Compound Name: (1S,2S)-2-Amino-2,3-dihydro-1H-inden-1-ol

CAS No.: 32151-02-3

Cat. No.: B3189406

[Get Quote](#)

Welcome to the technical support center for the synthesis of cis-1-amino-2-indanol and its derivatives. This guide is designed for researchers, scientists, and drug development professionals who are navigating the complexities of stereoselective synthesis. cis-1-amino-2-indanol is a critical chiral building block in modern organic chemistry, serving as a precursor to a wide array of ligands, catalysts, and bioactive molecules.<sup>[1][2][3]</sup> The primary challenge in its synthesis lies in the precise control of the relative stereochemistry of the amino and hydroxyl groups to favor the cis configuration.<sup>[1][3][4]</sup>

This document provides in-depth troubleshooting guides, frequently asked questions (FAQs), and detailed experimental protocols to empower you to overcome common hurdles and achieve high cis-selectivity in your reactions.

## Troubleshooting Guide: Common Issues and Solutions

This section addresses specific problems you may encounter during the synthesis of cis-1-amino-2-indanol, offering explanations and actionable solutions based on established chemical

principles.

Problem	Potential Cause(s)	Recommended Solution(s)
Low cis to trans ratio	<p>1. Inefficient stereocontrol in the key bond-forming step: The chosen synthetic route may not inherently favor the formation of the cis isomer. 2. Epimerization: Reaction conditions (e.g., harsh pH, high temperature) might be causing the product to isomerize to the more thermodynamically stable trans isomer. 3. Incorrect choice of reducing agent: For syntheses involving the reduction of a 2-amino-1-indanone precursor, the reducing agent may not provide the desired facial selectivity.</p>	<p>1. Re-evaluate your synthetic strategy: Consider routes known for high cis-selectivity, such as the Ritter reaction from indene oxide or intramolecular amide cyclization.[1][5] 2. Optimize reaction conditions: Maintain neutral or slightly acidic/basic conditions as appropriate for your specific reaction. Lowering the reaction temperature can often improve stereoselectivity.[6] 3. Select a suitable reducing agent: For the reduction of 2-amino-1-indanones, consider bulky hydride sources that favor attack from the less hindered face, or employ stereodirecting protecting groups on the amine.</p>
Poor enantioselectivity	<p>1. Ineffective chiral catalyst or auxiliary: The chiral source may not be providing a sufficiently differentiated energetic barrier between the two enantiomeric transition states. 2. Racemization: The product may be racemizing under the reaction or workup conditions. 3. Impure chiral catalyst: The catalyst may be of low enantiomeric purity.</p>	<p>1. Screen alternative chiral catalysts/ligands: For reactions like the Corey-Bakshi-Shibata (CBS) reduction, ensure the use of a highly enantiopure oxazaborolidine catalyst.[7][8] 2. Modify workup procedure: Use mild acidic or basic conditions during extraction and purification to prevent racemization. 3. Verify catalyst purity: Confirm the</p>

enantiomeric excess (ee) of your catalyst before use.

---

Formation of byproducts	<p>1. Side reactions: Competing reaction pathways may be leading to the formation of undesired products. For instance, in the Ritter reaction, rearrangement of the carbocation intermediate can occur. 2. Over-reduction or incomplete reaction: In reduction steps, other functional groups may be reduced, or the starting material may not be fully consumed.</p>	<p>1. Fine-tune reaction conditions: Adjust temperature, reaction time, and stoichiometry of reagents to minimize side reactions. In the Ritter reaction, the choice of acid and solvent is critical.[1] 2. Monitor reaction progress: Use techniques like Thin Layer Chromatography (TLC) or High-Performance Liquid Chromatography (HPLC) to track the reaction and stop it at the optimal time.[6]</p>
-------------------------	---	---

---

Difficulty in product isolation/purification	<p>1. Similar polarity of cis and trans isomers: The diastereomers may be difficult to separate by standard column chromatography. 2. Product is an oil: The final product may not crystallize easily.</p>	<p>1. Derivative formation: Consider converting the amino alcohol to a crystalline derivative (e.g., an amide or a salt with a chiral acid) to facilitate separation by recrystallization.[1] 2. Optimize recrystallization solvent system: Screen a variety of solvents and solvent mixtures to induce crystallization.</p>
--	--	--

---

## Frequently Asked Questions (FAQs)

Here we address common questions regarding the strategies to control cis-selectivity in aminoindanol synthesis.

Q1: What are the most reliable methods for achieving high cis-selectivity?

A1: Several strategies have been developed to afford high cis-selectivity.<sup>[1][2][4]</sup> Two of the most robust methods are:

- The Ritter Reaction from Indene Oxide: This method involves the opening of an epoxide ring with a nitrile in the presence of an acid, followed by hydrolysis. The mechanism proceeds through a five-membered ring intermediate that constrains the stereochemistry, leading to the cis product.<sup>[1][5]</sup>
- Intramolecular Amide Cyclization: This strategy involves the cyclization of an acyclic precursor containing an amide/urethane and a leaving group. The stereochemistry is set in the acyclic precursor, and the cyclization proceeds in a way that forms the cis product.<sup>[1][9]</sup>

Q2: How does the Corey-Bakshi-Shibata (CBS) reduction contribute to stereocontrol in aminoindanol synthesis?

A2: The CBS reduction is a powerful tool for the enantioselective reduction of prochiral ketones to secondary alcohols using a chiral oxazaborolidine catalyst and borane.<sup>[7][8][10]</sup> In the context of aminoindanol synthesis, if you have a 2-amino-1-indanone precursor, the CBS reduction can be used to reduce the ketone to the corresponding alcohol with high enantioselectivity. The choice of the (R)- or (S)-catalyst determines which enantiomer of the alcohol is formed. The cis or trans selectivity will then depend on the directing effect of the adjacent amino group.

Q3: Can the trans-aminoindanol be converted to the desired cis-isomer?

A3: Yes, epimerization of the less desired trans-isomer to the cis-isomer is a viable strategy. One common method is the Mitsunobu reaction at the C2 position, which proceeds with an inversion of configuration.<sup>[1]</sup> This allows for the conversion of a trans-azido or phthalimido alcohol to the corresponding cis-isomer.

Q4: What is the role of protecting groups in controlling stereoselectivity?

A4: Protecting groups on the amino functionality can play a crucial role in directing the stereochemical outcome of subsequent reactions. For example, a bulky protecting group on the nitrogen of a 2-amino-1-indanone can influence the facial selectivity of a hydride reduction of the ketone, thereby favoring the formation of one diastereomer over the other.

## Experimental Protocols

The following are detailed protocols for key reactions used to synthesize cis-1-amino-2-indanol with high stereoselectivity.

### Protocol 1: cis-Selective Synthesis via Ritter Reaction from Indene Oxide

This protocol describes the synthesis of racemic cis-1-amino-2-indanol starting from indene oxide.

#### Step 1: Epoxidation of Indene

- Dissolve indene in a suitable solvent such as dichloromethane.
- Add a peroxy acid (e.g., m-chloroperoxybenzoic acid, m-CPBA) portion-wise at 0 °C.
- Stir the reaction mixture at room temperature until the reaction is complete (monitor by TLC).
- Work up the reaction by washing with a solution of sodium bicarbonate and then brine.
- Dry the organic layer over anhydrous sodium sulfate, filter, and concentrate under reduced pressure to obtain indene oxide.

#### Step 2: Ritter Reaction and Hydrolysis

- Dissolve indene oxide in a mixture of acetonitrile and a suitable acid (e.g., sulfuric acid or perchloric acid) at 0 °C.
- Allow the reaction to warm to room temperature and stir until the starting material is consumed.
- Carefully add water to the reaction mixture and heat to reflux to hydrolyze the intermediate nitrilium ion.
- Cool the reaction mixture and neutralize with a base (e.g., sodium hydroxide).
- Extract the product with an organic solvent (e.g., ethyl acetate).

- Dry the organic layer, concentrate, and purify the crude product by column chromatography or recrystallization to obtain cis-1-amino-2-indanol.

## Protocol 2: Enantioselective Reduction of 2-Amino-1-indanone using CBS Catalyst

This protocol outlines the general procedure for the enantioselective reduction of a protected 2-amino-1-indanone to the corresponding cis-amino alcohol.

### Step 1: Preparation of the CBS Catalyst Solution

- Under an inert atmosphere (e.g., argon or nitrogen), dissolve the chiral oxazaborolidine catalyst (e.g., (R)- or (S)-Me-CBS) in anhydrous tetrahydrofuran (THF).

### Step 2: Reduction Reaction

- To the catalyst solution at room temperature, add a solution of borane-dimethyl sulfide complex (BMS) or borane-THF complex dropwise.
- Cool the mixture to the desired temperature (e.g., 0 °C or -20 °C).
- Add a solution of the N-protected 2-amino-1-indanone in anhydrous THF dropwise.
- Stir the reaction at the same temperature until complete conversion is observed (monitor by TLC or HPLC).

### Step 3: Workup and Purification

- Quench the reaction by the slow addition of methanol.
- Allow the mixture to warm to room temperature.
- Remove the solvent under reduced pressure.
- Add a suitable acidic solution (e.g., 1M HCl) to hydrolyze the borate esters.
- Extract the product with an organic solvent.

- Wash the organic layer with brine, dry over anhydrous sodium sulfate, and concentrate.
- Purify the product by column chromatography to obtain the enantiomerically enriched cis-1-amino-2-indanol derivative.

## Visualizing Key Concepts

### Transition State Model for CBS Reduction

The following diagram illustrates the proposed six-membered ring transition state for the CBS reduction of a ketone, which explains the high enantioselectivity observed. The ketone coordinates to the Lewis acidic boron of the catalyst in a way that minimizes steric interactions, leading to hydride delivery from one face of the carbonyl.<sup>[7][10]</sup>

Transition state of CBS reduction.

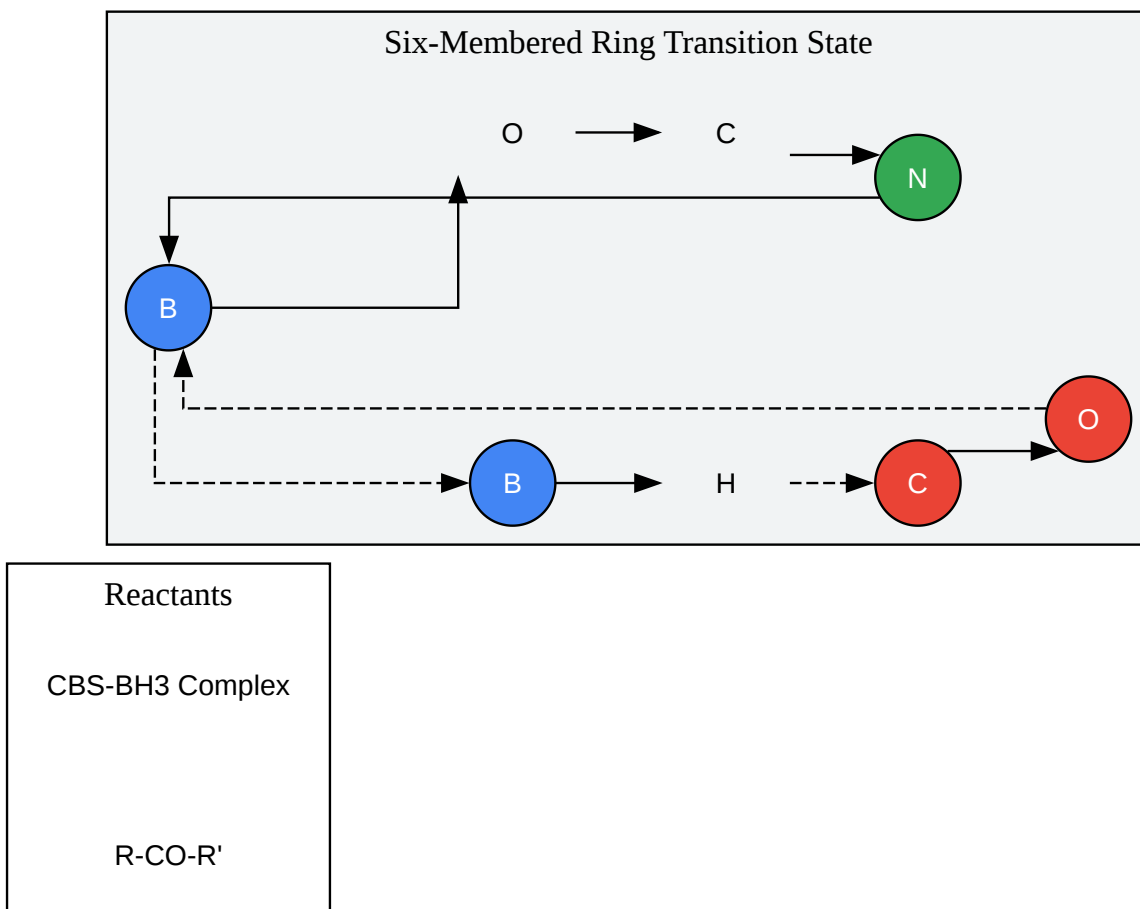

[Click to download full resolution via product page](#)

Caption: Transition state of CBS reduction.

## General Workflow for Troubleshooting Stereoselectivity

This flowchart outlines a logical approach to troubleshooting poor stereoselectivity in your aminoindanol synthesis.

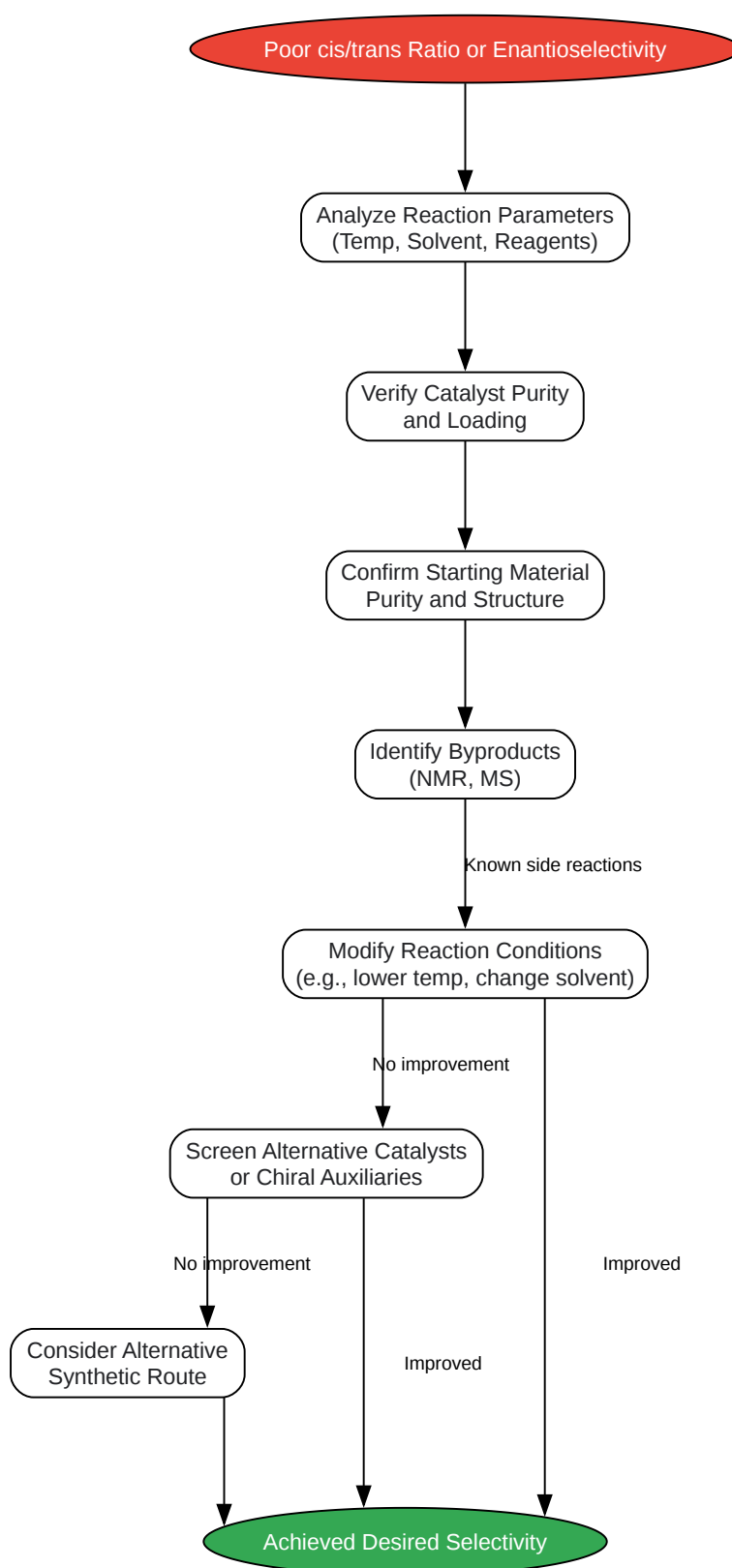

[Click to download full resolution via product page](#)

Caption: Troubleshooting workflow for stereoselectivity.

## References

- Mendas, I., Gastaldi, S., & Suppo, J.-S. (2024). Strategies for Accessing cis-1-Amino-2-Indanol. *Molecules*, 29(11), 2442. [[Link](#)]
- ResearchGate. (n.d.). Main strategies developed for the synthesis of cis-1-amino-2-indanol. Retrieved from [[Link](#)]
- Ghosh, A. K., & Fidanze, S. (2000). Enantioselective Synthesis of Cyclic Amino Alcohols: cis-1-Amino-2-indanol. *Organic Syntheses*, 77, 183. [[Link](#)]
- Gao, Y., Jones, G. B., & Aslanian, R. G. (2006). cis-1-Amino-2-indanol in Drug Design and Applications to Asymmetric Processes. *Chemical Reviews*, 106(7), 2843–2874. [[Link](#)]
- Mendas, I., Gastaldi, S., & Suppo, J.-S. (2024). Strategies for Accessing cis-1-Amino-2-Indanol. PubMed. [[Link](#)]
- Organic Chemistry Portal. (n.d.). Corey-Bakshi-Shibata Reduction. Retrieved from [[Link](#)]
- ResearchGate. (n.d.). (PDF) Strategies for Accessing cis-1-Amino-2-Indanol. Retrieved from [[Link](#)]
- ResearchGate. (n.d.). The Corey-Bakshi-Shibata Reduction: Mechanistic and Synthetic Considerations. Retrieved from [[Link](#)]
- Wikipedia. (n.d.). Corey–Itsuno reduction. Retrieved from [[Link](#)]
- YouTube. (2021, May 1). Corey-Itsuno, Corey-Bakshi-Shibata Reduction. Retrieved from [[Link](#)]
- ResearchGate. (n.d.). Factors affecting stereoselectivity. Retrieved from [[Link](#)]
- Royal Society of Chemistry. (n.d.). Diastereoselective access to 2-aminoindanones via the rhodium(ii)-catalyzed tandem reaction involving O–H insertion and Michael addition. Retrieved from [[Link](#)]
- Mendas, I., Gastaldi, S., & Suppo, J.-S. (2024). Strategies for Accessing cis-1-Amino-2-Indanol. PMC. [[Link](#)]

- Master Organic Chemistry. (2010, July 2). Stereoselective and Stereospecific Reactions. Retrieved from [[Link](#)]

### Need Custom Synthesis?

BenchChem offers custom synthesis for rare earth carbides and specific isotopic labeling.

Email: [info@benchchem.com](mailto:info@benchchem.com) or [Request Quote Online](#).

## Sources

- 1. Strategies for Accessing cis-1-Amino-2-Indanol | MDPI [[mdpi.com](https://www.mdpi.com)]
- 2. [researchgate.net](https://www.researchgate.net) [[researchgate.net](https://www.researchgate.net)]
- 3. Strategies for Accessing cis-1-Amino-2-Indanol - PubMed [[pubmed.ncbi.nlm.nih.gov](https://pubmed.ncbi.nlm.nih.gov)]
- 4. [researchgate.net](https://www.researchgate.net) [[researchgate.net](https://www.researchgate.net)]
- 5. [researchgate.net](https://www.researchgate.net) [[researchgate.net](https://www.researchgate.net)]
- 6. [pdf.benchchem.com](https://pdf.benchchem.com) [[pdf.benchchem.com](https://pdf.benchchem.com)]
- 7. [alfa-chemistry.com](https://www.alfa-chemistry.com) [[alfa-chemistry.com](https://www.alfa-chemistry.com)]
- 8. Corey-Bakshi-Shibata Reduction [[organic-chemistry.org](https://www.organic-chemistry.org)]
- 9. Strategies for Accessing cis-1-Amino-2-Indanol - PMC [[pubmed.ncbi.nlm.nih.gov](https://pubmed.ncbi.nlm.nih.gov)]
- 10. Corey–Itsuno reduction - Wikipedia [[en.wikipedia.org](https://en.wikipedia.org)]
- To cite this document: BenchChem. [Technical Support Center: Mastering cis-Selectivity in Aminoindanol Synthesis]. BenchChem, [2026]. [Online PDF]. Available at: [<https://www.benchchem.com/product/b3189406/docs#technical-support-center-mastering-cis-selectivity-in-aminoindanol-synthesis>]

---

### Disclaimer & Data Validity:

The information provided in this document is for Research Use Only (RUO) and is strictly not intended for diagnostic or therapeutic procedures. While BenchChem strives to provide accurate protocols, we make no warranties, express or implied, regarding the fitness of this product for every specific experimental setup.

**Technical Support:** The protocols provided are for reference purposes. Unsure if this reagent suits your experiment?

**Need Industrial/Bulk Grade?** [Request Custom Synthesis Quote](#)

## BenchChem

Our mission is to be the trusted global source of essential and advanced chemicals, empowering scientists and researchers to drive progress in science and industry.

### Contact

Address: 3281 E Guasti Rd  
Ontario, CA 91761, United States  
Phone: (601) 213-4426  
Email: [info@benchchem.com](mailto:info@benchchem.com)

[Contact our Ph.D. Support Team for a compatibility check](#)