

Technical Support Center: Refining Derazantinib Racemate Treatment Protocols

Author: BenchChem Technical Support Team. **Date:** December 2025

Compound of Interest

Compound Name: *Derazantinib Racemate*

Cat. No.: *B3182171*

[Get Quote](#)

This technical support center provides troubleshooting guides and frequently asked questions (FAQs) to assist researchers, scientists, and drug development professionals in optimizing their experiments with **derazantinib racemate**.

Frequently Asked Questions (FAQs)

Q1: What is derazantinib and its mechanism of action?

A1: Derazantinib is an orally bioavailable, ATP-competitive inhibitor of fibroblast growth factor receptors (FGFRs), with potent activity against FGFR1, FGFR2, and FGFR3.[1] It functions by binding to the ATP-binding pocket of the FGFR kinase domain, thereby preventing phosphorylation and activation of downstream signaling pathways. This inhibition ultimately leads to decreased cell proliferation and tumor growth in cancers with FGFR pathway dysregulation.[2]

Q2: What is the difference between derazantinib and **derazantinib racemate**?

A2: **Derazantinib racemate** (also referred to as ARQ-087 racemate) is the racemic mixture of derazantinib.[3] A racemate contains equal amounts of left- and right-handed enantiomers of a chiral molecule. For research purposes, it is crucial to be aware of which form is being used, as the pharmacological activity may reside in one enantiomer.

Q3: What are the known resistance mechanisms to derazantinib and other FGFR inhibitors?

A3: Resistance to FGFR inhibitors can arise through several mechanisms, including:

- Secondary mutations in the FGFR kinase domain: These mutations can interfere with drug binding.
- Activation of bypass signaling pathways: Cancer cells may activate alternative signaling pathways to circumvent the FGFR blockade.

Q4: What are the common adverse events observed in clinical trials with derazantinib?

A4: Common treatment-related adverse events observed in clinical trials include hyperphosphatemia, asthenia/fatigue, nausea, dry mouth, and diarrhea.[4]

Troubleshooting Guides

In Vitro Assays

Problem: High variability or unexpected results in cell viability assays (e.g., MTT, CCK-8).

- Possible Cause 1: Suboptimal Cell Seeding Density.
 - Recommendation: Perform a cell titration experiment to determine the optimal seeding density for each cell line. For many cancer cell lines, a starting density of 5,000-10,000 cells/well in a 96-well plate is recommended. Ensure cells are in the logarithmic growth phase.
- Possible Cause 2: Inconsistent Drug Concentration.
 - Recommendation: Prepare fresh serial dilutions of derazantinib for each experiment. Ensure thorough mixing at each dilution step. Use a calibrated pipette for accurate dispensing.
- Possible Cause 3: Edge Effects in Microplates.
 - Recommendation: To minimize evaporation and temperature gradients, avoid using the outer wells of the microplate for experimental samples. Fill the perimeter wells with sterile phosphate-buffered saline (PBS) or culture medium.

- Possible Cause 4: Contamination.
 - Recommendation: Regularly test cell cultures for mycoplasma contamination. Practice sterile techniques throughout the experimental process.

Problem: Weak or no signal in Western blot for phospho-FGFR.

- Possible Cause 1: Insufficient Inhibition of Phosphatases.
 - Recommendation: Include phosphatase inhibitors (e.g., sodium orthovanadate, sodium fluoride) in your cell lysis buffer and maintain samples on ice to preserve phosphorylation status.
- Possible Cause 2: Inappropriate Antibody Dilution.
 - Recommendation: Optimize the primary antibody concentration. For phospho-FGFR (pan-tyrosine) antibodies, a starting dilution of 1:1000 is often recommended.[4] Refer to the antibody datasheet for specific guidance.
- Possible Cause 3: Low Protein Concentration.
 - Recommendation: Ensure you are loading a sufficient amount of total protein per lane (typically 20-40 µg). Perform a protein concentration assay (e.g., BCA) to accurately quantify your lysates.
- Possible Cause 4: Inefficient Protein Transfer.
 - Recommendation: Verify the efficiency of your protein transfer from the gel to the membrane (e.g., using Ponceau S staining). Optimize transfer time and voltage as needed.

In Vivo Assays (Xenograft Models)

Problem: Inconsistent tumor growth or high mortality in animal models.

- Possible Cause 1: Poor Tumor Cell Viability.

- Recommendation: Use highly viable tumor cells for implantation (ideally >90%). Handle cells gently and implant them promptly after harvesting.
- Possible Cause 2: Suboptimal Tumor Implantation Site or Technique.
 - Recommendation: Ensure consistent subcutaneous or orthotopic implantation. For subcutaneous models, inject a consistent volume and cell number into the same anatomical location for all animals.
- Possible Cause 3: Inconsistent Drug Formulation and Administration.
 - Recommendation: Prepare a fresh and homogenous suspension of derazantinib for each dosing. Ensure accurate oral gavage technique to minimize stress and ensure consistent delivery to the stomach.
- Possible Cause 4: Animal Health Issues.
 - Recommendation: Closely monitor animal health, including body weight, food and water intake, and clinical signs of distress. Consult with veterinary staff if any issues arise.

Quantitative Data Summary

Table 1: In Vitro Efficacy of Derazantinib

Target	IC50 (nM)	Cell Line	Assay Type	Reference
FGFR1	4.5	-	Kinase Assay	[1]
FGFR2	1.8	-	Kinase Assay	[1]
FGFR3	4.5	-	Kinase Assay	[1]
FGFR4	34	-	Kinase Assay	[1]
SNU-16	0.1-1.7 μ M (GI50)	Gastric Cancer	Cell Growth	[2]
NCI-H716	0.1-1.7 μ M (GI50)	Colorectal Cancer	Cell Growth	[2]

Table 2: Clinical Efficacy of Derazantinib in the FIDES-01 Trial (Intrahepatic Cholangiocarcinoma)

Patient Cohort	Objective Response Rate (ORR)	Disease Control Rate (DCR)	Median Progression-Free Survival (PFS)	Median Overall Survival (OS)	Reference
FGFR2 Fusions	21.4%	75.7%	7.8 months	17.2 months	[5]
FGFR2 Mutations/Amplifications	6.5%	58.1%	8.3 months	15.9 months	[2]

Table 3: Clinical Efficacy of Derazantinib in the FIDES-02 Trial (Metastatic Urothelial Carcinoma)

Substudy	Objective Response Rate (ORR)	Disease Control Rate (DCR)	Median Progression-Free Survival (PFS)	Median Overall Survival (OS)	Reference
Substudies 1 & 5 (Monotherapy)	8.2%	30.6%	2.1 months	6.6 months	[6]
Substudy 4 (Monotherapy)	14.3%	-	-	-	[7]

Table 4: Human Pharmacokinetic Parameters of Derazantinib

Parameter	Value	Condition	Reference
C _{max}	172 ng/mL	300 mg oral dose	[8]
T _{max}	4.53 h	300 mg oral dose	[8]
Oral Bioavailability	56%	-	[8]

Experimental Protocols

Protocol 1: Cell Viability (MTT) Assay

- **Cell Seeding:** Seed cancer cells (e.g., SNU-16, NCI-H716) in a 96-well plate at a pre-determined optimal density (e.g., 5,000 cells/well) in 100 µL of complete growth medium. Incubate for 24 hours at 37°C and 5% CO₂.
- **Drug Treatment:** Prepare a 2X stock solution of **derazantinib racemate** in culture medium. Remove the old medium from the wells and add 100 µL of the 2X drug solution to the respective wells. Include vehicle control wells (e.g., 0.1% DMSO). Incubate for 72 hours.
- **MTT Addition:** Add 10 µL of 5 mg/mL MTT solution to each well and incubate for 4 hours at 37°C.
- **Formazan Solubilization:** Carefully remove the medium and add 100 µL of DMSO to each well to dissolve the formazan crystals.
- **Absorbance Measurement:** Measure the absorbance at 570 nm using a microplate reader.

Protocol 2: Western Blotting for Phospho-FGFR

- **Cell Lysis:** Treat cells with derazantinib as required. Wash cells with ice-cold PBS and lyse with RIPA buffer supplemented with protease and phosphatase inhibitors.
- **Protein Quantification:** Determine the protein concentration of each lysate using a BCA assay.
- **SDS-PAGE:** Load equal amounts of protein (e.g., 30 µg) onto an SDS-polyacrylamide gel and perform electrophoresis.

- Protein Transfer: Transfer the separated proteins to a PVDF membrane.
- Blocking: Block the membrane with 5% non-fat dry milk or BSA in Tris-buffered saline with 0.1% Tween 20 (TBST) for 1 hour at room temperature.
- Primary Antibody Incubation: Incubate the membrane with a primary antibody against phospho-FGFR (e.g., pan-Tyr, diluted 1:1000 in 5% BSA/TBST) overnight at 4°C.
- Secondary Antibody Incubation: Wash the membrane with TBST and incubate with an appropriate HRP-conjugated secondary antibody for 1 hour at room temperature.
- Detection: Visualize the protein bands using an enhanced chemiluminescence (ECL) detection system.

Protocol 3: In Vivo Xenograft Study

- Tumor Cell Implantation: Subcutaneously inject a suspension of cancer cells (e.g., 5×10^6 SNU-16 cells in 100 μ L of PBS/Matrigel) into the flank of immunodeficient mice.
- Tumor Growth Monitoring: Monitor tumor growth by measuring tumor volume with calipers (Volume = (length x width²)/2).
- Treatment Initiation: When tumors reach a mean volume of 100-150 mm³, randomize the animals into treatment and control groups.
- Drug Administration: Administer **derazantinib racemate** orally (e.g., by gavage) at the desired dose and schedule. The vehicle control group should receive the same volume of the vehicle solution.
- Endpoint Analysis: Monitor tumor volume and body weight regularly. At the end of the study, euthanize the animals and excise the tumors for further analysis (e.g., weight, histology, biomarker analysis).

Visualizations

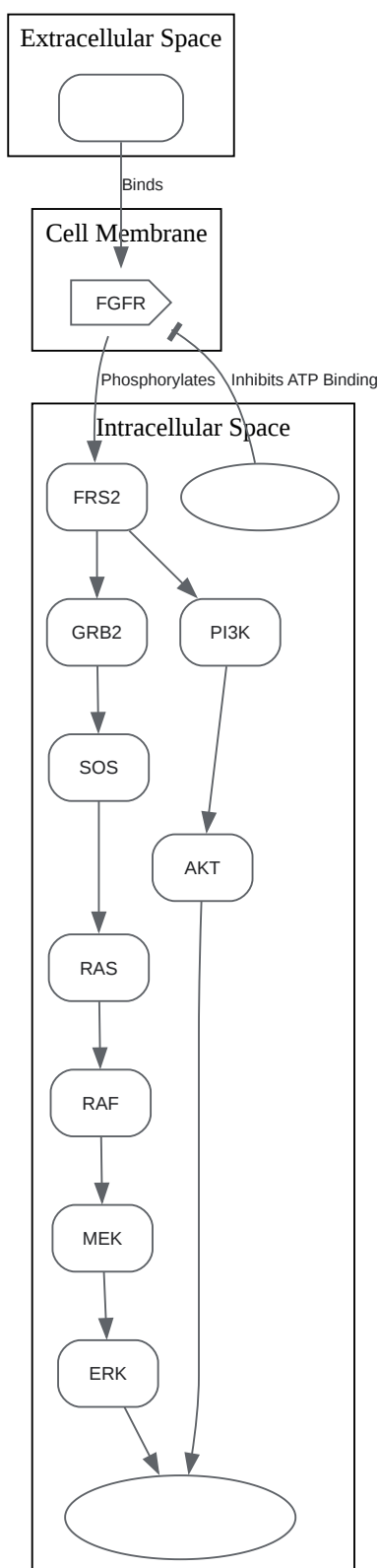

[Click to download full resolution via product page](#)

Caption: Derazantinib inhibits the FGFR signaling pathway.

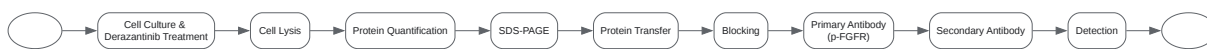

[Click to download full resolution via product page](#)

Caption: Western blot workflow for p-FGFR detection.

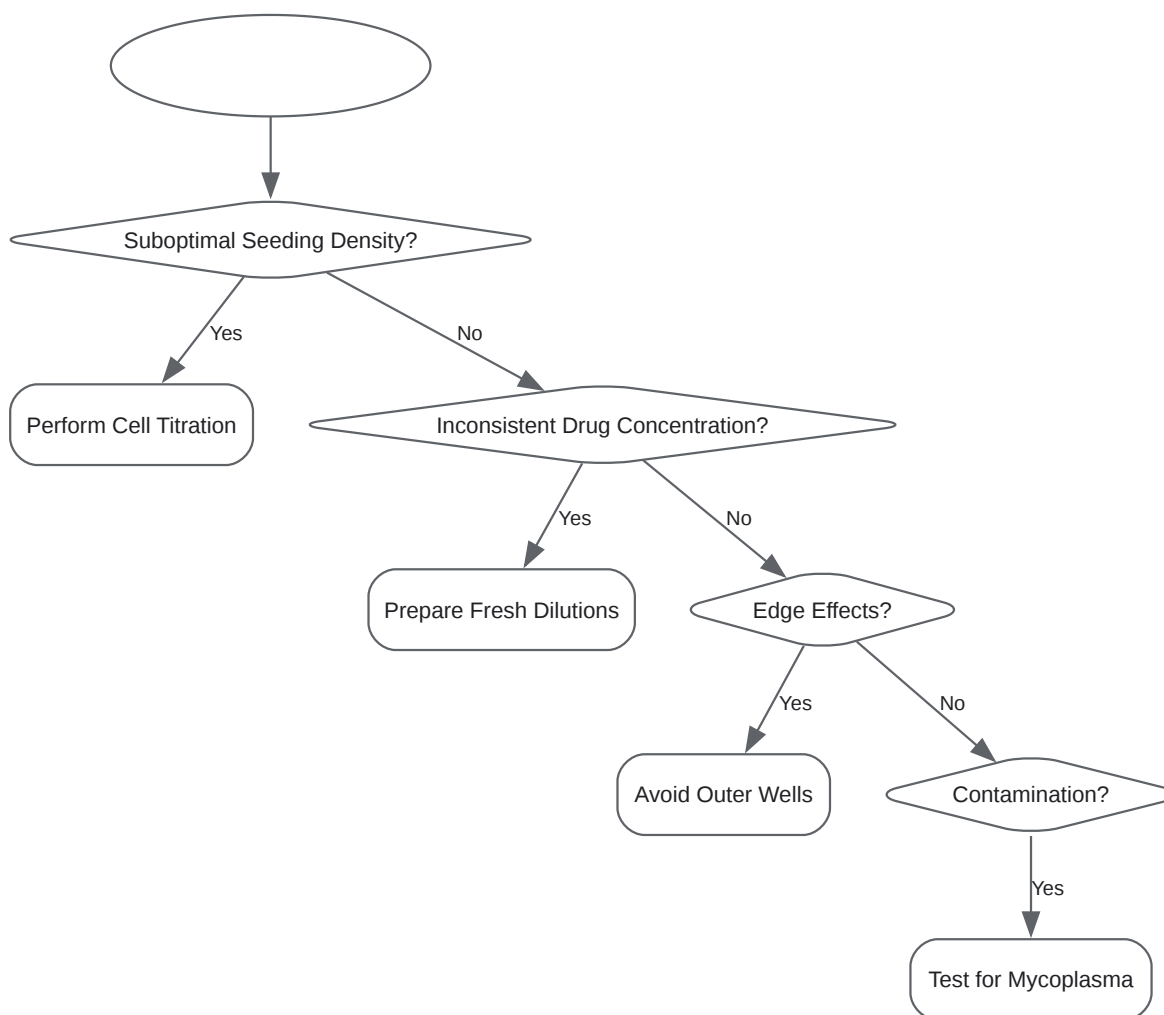

[Click to download full resolution via product page](#)

Caption: Troubleshooting cell viability assay variability.

Need Custom Synthesis?

BenchChem offers custom synthesis for rare earth carbides and specific isotopic labeling.

Email: info@benchchem.com or [Request Quote Online](#).

References

- 1. Understanding and Overcoming Resistance to Selective FGFR Inhibitors across FGFR2-Driven Malignancies - PMC [[pmc.ncbi.nlm.nih.gov](https://pubmed.ncbi.nlm.nih.gov/)]
- 2. SNU-16 Xenograft Model - Altogen Labs [altogenlabs.com]
- 3. texaschildrens.org [texaschildrens.org]
- 4. Phospho-FGFR1 (Tyr653, Tyr654) Polyclonal Antibody (44-1140G) [thermofisher.com]
- 5. Protocol for Cell Viability Assays: CCK-8 and MTT - Creative Biogene [creative-biogene.com]
- 6. Cell Viability Assays - Assay Guidance Manual - NCBI Bookshelf [[ncbi.nlm.nih.gov](https://pubmed.ncbi.nlm.nih.gov/)]
- 7. oncotarget.com [oncotarget.com]
- 8. Phospho-FGFR Pan (Tyr653, Tyr654) Polyclonal Antibody (PA5-64626) [thermofisher.com]
- To cite this document: BenchChem. [Technical Support Center: Refining Derazantinib Racemate Treatment Protocols]. BenchChem, [2025]. [Online PDF]. Available at: [<https://www.benchchem.com/product/b3182171#refining-derazantinib-racemate-treatment-protocols>]

Disclaimer & Data Validity:

The information provided in this document is for Research Use Only (RUO) and is strictly not intended for diagnostic or therapeutic procedures. While BenchChem strives to provide accurate protocols, we make no warranties, express or implied, regarding the fitness of this product for every specific experimental setup.

Technical Support: The protocols provided are for reference purposes. Unsure if this reagent suits your experiment? [[Contact our Ph.D. Support Team for a compatibility check](#)]

Need Industrial/Bulk Grade? [Request Custom Synthesis Quote](#)

BenchChem

Our mission is to be the trusted global source of essential and advanced chemicals, empowering scientists and researchers to drive progress in science and industry.

Contact

Address: 3281 E Guasti Rd

Ontario, CA 91761, United States

Phone: (601) 213-4426

Email: info@benchchem.com