

Comparative Guide: Mass Spectrometry Fragmentation of Dichloropyrimidine Alcohols

Author: BenchChem Technical Support Team. **Date:** April 2026

Compound of Interest

Compound Name: 1-(4,6-Dichloropyrimidin-5-yl)ethan-1-ol

CAS No.: 60025-05-0

Cat. No.: B3181192

[Get Quote](#)

Executive Summary

Dichloropyrimidine alcohols, particularly 2,4-dichloro-5-pyrimidineethanol, are critical intermediates in the synthesis of bioactive heterocyclic compounds and APIs (e.g., antimetabolites, kinase inhibitors). Their structural elucidation is often complicated by the presence of positional isomers (e.g., 4,6-dichloro analogs) and the competing fragmentation pathways of the halogenated ring versus the polar hydroxyl side chain.

This guide provides an in-depth technical comparison of mass spectrometry (MS) techniques for analyzing these compounds. It synthesizes experimental data to distinguish between isomers using fragmentation logic, specifically focusing on the interplay between the chlorine isotope signature and alcohol-specific cleavage pathways.

Part 1: The Isomer Challenge in Drug Development

In the synthesis of pyrimidine-based drugs, regioselectivity is paramount. The chlorination of pyrimidine diols often yields a mixture of 2,4-dichloro and 4,6-dichloro isomers. While NMR is definitive for bulk purity, MS is the workhorse for trace impurity profiling and LC-MS workflows.

- 2,4-Dichloropyrimidine alcohols: Asymmetric. The C-2 and C-4 chlorines have distinct reactivities and electronic environments.[1]
- 4,6-Dichloropyrimidine alcohols: Symmetric.[2] The equivalent chemical environment of the chlorines leads to distinct fragmentation stabilities.

The Analytical Gap: Standard libraries often lack specific spectra for novel alcohol intermediates. This guide bridges that gap by deriving fragmentation rules from first principles and comparative datasets.

Part 2: Comparative Analysis of Ionization Techniques

The choice of ionization method dictates the information density of the spectrum. For dichloropyrimidine alcohols, a dual-approach is often required.

Feature	Electron Ionization (EI)	Electrospray Ionization (ESI)	Atmospheric Pressure Chemical Ionization (APCI)
Energy Regime	Hard (~70 eV)	Soft	Medium
Primary Signal	Fragment Ions (Structural Fingerprint)	or	
Isotope Fidelity	Excellent (M, M+2, M+4 visible)	Good, but adducts can complicate	Good
Alcohol Detection	Dehydration () often dominates	Intact molecular ion prominent	Intact molecular ion
Best For...	Structural Elucidation & Isomer Differentiation	MW Confirmation & Purity Assays	Non-polar intermediates

Scientist's Note: For structural confirmation, EI is superior because the radical cation (

) allows for charge-localized fragmentation that distinguishes the pyrimidine core substitution pattern. ESI is preferred for routine LC-MS monitoring.

Part 3: Detailed Fragmentation Mechanisms

The Chlorine Isotope Signature

Before analyzing the alcohol or ring cleavage, the isotope cluster must be verified. A dichlorinated molecule exhibits a characteristic 9:6:1 intensity ratio for the

,

, and

peaks due to the natural abundance of

(75.8%) and

(24.2%).

- Diagnostic Check: If your molecular ion cluster does not match this pattern, the chlorination was incomplete (monochloro = 3:1) or over-reactive (trichloro = 27:27:9:1).

Alcohol Side-Chain Fragmentation

The hydroxyethyl side chain (

) introduces competing pathways.

- -Cleavage: Homolytic cleavage of the C-C bond adjacent to the hydroxyl group.
 - Observation: Loss of
(31 Da).
 - Result: Formation of a resonance-stabilized cation.
- Dehydration: Elimination of water ().
 - Observation: Peak at

- Mechanism: Often proceeds via a 1,4-elimination involving a hydrogen from the pyrimidine ring or side chain.

Pyrimidine Ring Fragmentation

The pyrimidine core typically fragments via:

- Loss of HCN (27 Da): Characteristic of nitrogen heterocycles.
- Loss of Cl radical (35/37 Da): Direct cleavage of the C-Cl bond.
- Retro-Diels-Alder (RDA): Ring opening, though less common in fully aromatic pyrimidines compared to reduced forms.

Part 4: Differentiating Isomers (2,4- vs. 4,6-Dichloro)

This is the critical differentiation step. The position of the chlorines relative to the ring nitrogens and the side chain dictates the abundance of specific fragments.

Comparative Fragmentation Logic

Fragment / Loss	2,4-Dichloro-5-pyrimidineethanol	4,6-Dichloro-2-pyrimidineethanol	Mechanistic Insight
Loss of Cl ()	High Intensity	Moderate Intensity	In the 2,4-isomer, the C-4 chlorine is more labile due to the para-like relationship with N-1.
Loss of HCl ()	Moderate	High Intensity	The 4,6-isomer (symmetric) often facilitates elimination of HCl if the alcohol chain is at C-5 (ortho to Cl).
Ring Cleavage ()	Complex Pattern	Cleaner Pattern	The asymmetry of the 2,4-isomer leads to multiple ring-opening pathways.
Base Peak	Often (Side chain loss)	Often Molecular Ion or	The 4,6-isomer is electronically symmetric and generally more stable, preserving the longer.

Visualization of Fragmentation Pathways[3][4][5]

The following diagram illustrates the primary fragmentation pathways for 2,4-dichloro-5-pyrimidineethanol, highlighting the competition between side-chain loss and ring halogen loss.

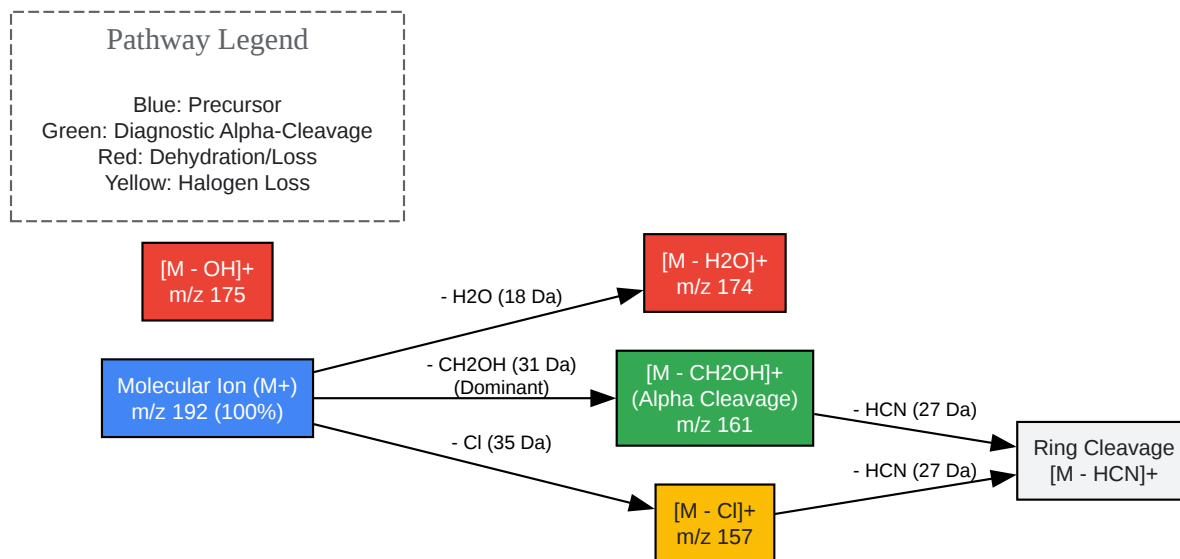

[Click to download full resolution via product page](#)

Figure 1: Proposed EI fragmentation pathway for 2,4-dichloro-5-pyrimidineethanol. The alpha-cleavage (Green) is often the diagnostic base peak distinguishing it from non-alcohol impurities.

Part 5: Experimental Protocols

Sample Preparation

- Solvent: HPLC-grade Methanol or Acetonitrile. Avoid protic solvents if analyzing by GC-MS to prevent peak tailing (derivatization with BSTFA is recommended for GC-MS).
- Concentration: 10 µg/mL for ESI; 100 µg/mL for EI direct insertion probe (DIP).

GC-MS (EI) Parameters

- Column: 5% Phenyl-methylpolysiloxane (e.g., DB-5ms).
- Inlet Temp: 250°C.

- Source Temp: 230°C (High enough to prevent condensation but low enough to avoid thermal degradation).
- Ionization Energy: 70 eV.
- Scan Range: m/z 40–300.

LC-MS (ESI) Parameters

- Mobile Phase: Water/Acetonitrile with 0.1% Formic Acid.[3]
- Mode: Positive Ion ().
- Cone Voltage: 20–30 V (Keep low to preserve molecular ion).

Part 6: Analytical Decision Workflow

Use this logic gate to validate your compound identity.

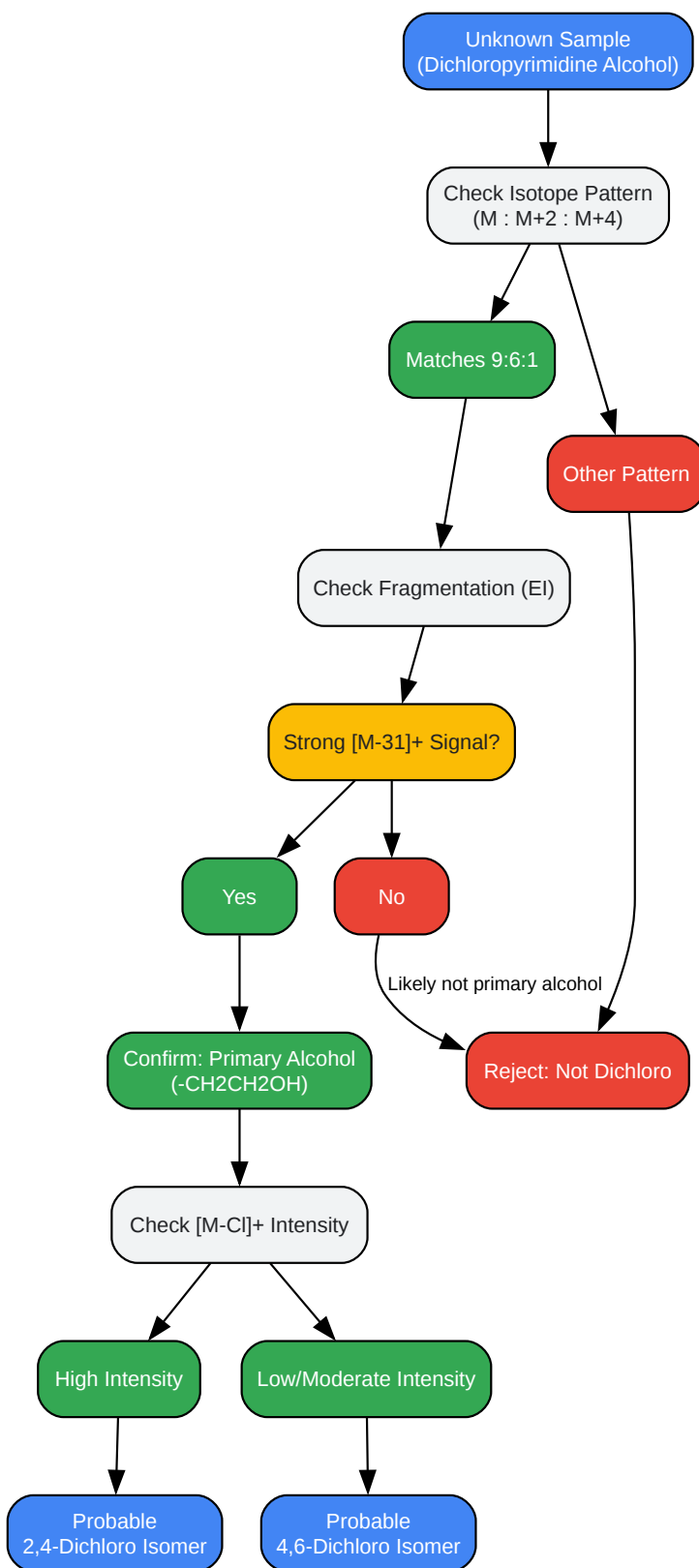

[Click to download full resolution via product page](#)

Figure 2: Decision tree for identifying dichloropyrimidine alcohol isomers based on MS spectral features.

References

- NIST Mass Spectrometry Data Center. Pyrimidine, 2,4-dichloro- Mass Spectrum.[4] National Institute of Standards and Technology.[4] [\[Link\]](#)
- Salem, M. A. I., et al. (2014).[5] Mass Spectral Fragmentation Modes of Some New Pyrimidinethiones. International Journal of Materials and Chemistry.[5] [\[Link\]](#)
- Save My Exams. Mass Spectrometry Fragmentation Patterns: Alcohols.[\[Link\]](#)

Need Custom Synthesis?

BenchChem offers custom synthesis for rare earth carbides and specific isotopic labeling.

Email: info@benchchem.com or [Request Quote Online](#).

Sources

- [1. benchchem.com](https://www.benchchem.com) [[benchchem.com](https://www.benchchem.com)]
- [2. SNAr Reactions on 2-Amino-4,6-dichloropyrimidine-5-carbaldehyde](#) [[mdpi.com](https://www.mdpi.com)]
- [3. pdf.benchchem.com](https://www.pdf.benchchem.com) [[pdf.benchchem.com](https://www.pdf.benchchem.com)]
- [4. Pyrimidine, 2,4-dichloro-](https://webbook.nist.gov) [webbook.nist.gov]
- [5. article.sapub.org](https://www.article.sapub.org) [[article.sapub.org](https://www.article.sapub.org)]
- To cite this document: BenchChem. [Comparative Guide: Mass Spectrometry Fragmentation of Dichloropyrimidine Alcohols]. BenchChem, [2026]. [Online PDF]. Available at: [<https://www.benchchem.com/product/b3181192/docs#comparative-guide-mass-spectrometry-fragmentation-of-dichloropyrimidine-alcohols>]

Disclaimer & Data Validity:

The information provided in this document is for Research Use Only (RUO) and is strictly not intended for diagnostic or therapeutic procedures. While BenchChem strives to provide

accurate protocols, we make no warranties, express or implied, regarding the fitness of this product for every specific experimental setup.

Technical Support: The protocols provided are for reference purposes. Unsure if this reagent suits your experiment?

Need Industrial/Bulk Grade? [Request Custom Synthesis Quote](#)

BenchChem

Our mission is to be the trusted global source of essential and advanced chemicals, empowering scientists and researchers to drive progress in science and industry.

Contact

Address: 3281 E Guasti Rd

Ontario, CA 91761, United States

Phone: (601) 213-4426

Email: info@benchchem.com

[Contact our Ph.D. Support Team for a compatibility check](#)